

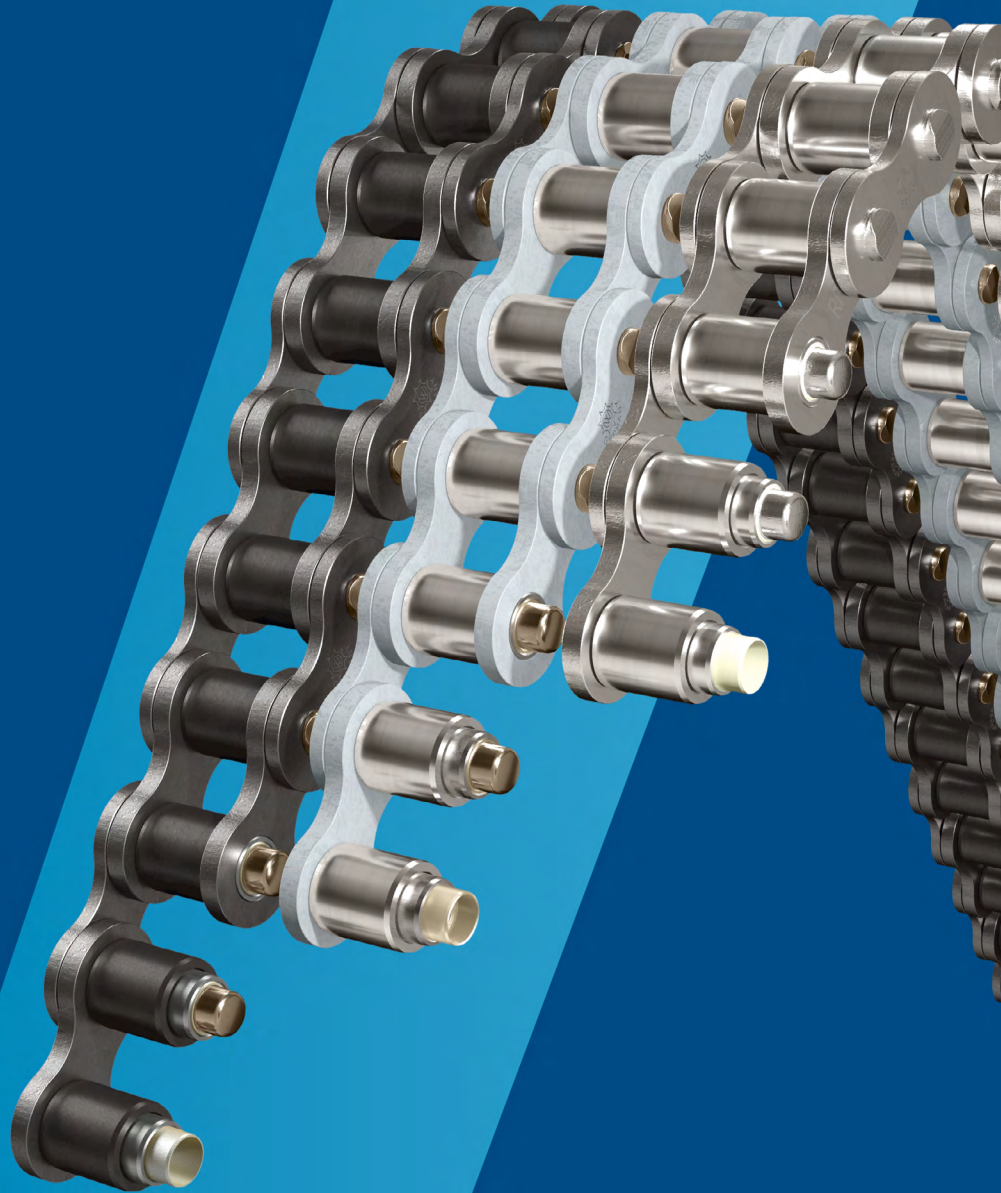

WIPPERMANN



MAIN CATALOGUE

Industrial Chains, Sprockets
and Accessories



Since 1893
Made in Germany

Product information

16	MARATHON Lift
22	Roller chains
22	Simplex roller chains according to ISO 606 (European type)
23	Duplex roller chains according to ISO 606 (European type)
24	Triplex roller chains according to ISO 606 (European type)
25	Simplex roller chains according to ISO 606 (American type)
26	Duplex roller chains according to ISO 606 (American type)
27	Triplex roller chains according to ISO 606 (American type)
28	Roller chains type series GL (straight plates)
29	Maintenance-free chains
30	BIATHLON
30	Roller chains according to ISO 606
32	BIATHLON KS
32	Roller chains according to ISO 606
33	Simplex-Roller chains according to ISO 606
34	Duplex-Roller chains according to ISO 606
35	Triplex-Roller chains according to ISO 606
36	TRIATHLON HT
36	Roller chains according to ISO 606
38	TRIATHLON KS
38	Roller chains according to ISO 606
40	MARATHON
42	Roller chains according to ISO 606
44	Roller chains type series GL (straight plates)
45	Double pitch roller chains according to ISO 1275
46	Accumulator chains
48	Roller chains stainless steel
48	MARATHON stainless steel
49	Roller chains according to ISO 606
50	Simplex roller chains (stainless steel) according to ISO 606
51	Duplex roller chains (stainless steel) according to ISO 606
52	Triplex roller chains (stainless steel) according to ISO 606
53	Side bow chains
54	POM-Clips
56	POM-Clips with top surface TPU
58	Simplex roller chains (factory standard) / Agricultural roller chains according to ISO 487
59	Special heavy duty chains / Power chains
60	Double pitch roller chains according to ISO 1275
61	Hollow pin chains
62	Roller chains with attachments
62	Roller chains
62	Roller chains with single hole bent attachments
63	Roller chains with single hole straight attachments and extended pins
64	Roller chains with two-hole bent and straight attachments
65	Roller chains (stainless steel) as attachment chains
66	Roller chains with single hole attachments and inside thread
67	Roller chains with two-hole attachments and inside thread
68	Double pitch roller chains
68	Double pitch roller chains with single hole bent attachments
69	Double pitch roller chains with single hole straight attachments and extended pins
70	Roller chains with extended pins on one side/both sides
71	Combination connecting links
72	Accumulator chains
74	Axial profile of sprockets for accumulator chains
74	Chain guide for accumulator chains
75	AFS-Clips
76	ATC chains
79	Request form ATC chains
80	Pusher dog
81	Special top plate conveyor chain
82	Leaf chains
82	Leaf chains type series LL according to DIN ISO 4347
83	Leaf chains according to factory standard
83	Leaf chains heavy duty design U according to factory standard
84	Leaf chains type series BL according to DIN ISO 4347 according to series LH
85	Plate end links and connecting pins

86	Bush chains
87	Inverted tooth chains with bushings (60° flank angle)
88	Inverted tooth (silent) chains
89	Inverted tooth (silent) chains type series HD
90	Inverted tooth (silent) chains type series HP
91	Additional product range
92	Sprockets
92	Sprockets for roller chains according to ISO 606
100	Sprockets (stainless steel) grade 1.4301
101	Sprockets for accumulator chains
101	Sprockets for hollow pin chains 01650
101	SPR tensioning wheels with integrated ball bearing
102	Sprockets with lantern gear toothing
103	Plate sprockets for simplex roller chains according to ISO 606
106	Chain couplings
107	Sprockets (made to specifications)
107	Groove sizes
108	Axial profile of sprockets for roller chains
109	Calculation of sprocket diameters
109	Toothing check
110	Details for orders and enquiries for sprockets
111	Mounting of chain drives
111	Faulty mounting
112	Values for "n" and cot α
113	Sprockets – PCD d_0 and tip circle diameter d_k
113	for roller chains according to ISO 606 and factory standard
116	Accessories
116	ETP bushings for shaft - to - hub connections
118	Automatic chain drive tensioning SPANN-BOX® / SPANN-BOY®
122	Slide rails made of polyethylene material

Technical information

110	Details for orders and enquiries for sprockets
111	Mounting of chain drives
111	Faulty mounting
125	Lubrication
128	WKS Sprays
129	WKS Lubricants
130	Various types of steel link chains
132	Advantages of roller chain drives
133	Formulas, designations and units
134	Pre-selection of leaf chains
136	Pre-selection of roller chain drives
138	Power diagram for roller chains according to ISO 606 (European type) / according to DIN ISO 10823
139	Power diagram for roller chains according to ISO 606 (American type) / according to DIN ISO 10823
140	Power diagram for roller chains according to ISO 606 (American type, reinforced) / according to DIN ISO 10823
141	Calculations
141	Calculation of chain length X
142	Calculation of shaft distance a
143	Determination of chain length L
144	Worked example
145	Construction of chain drives
146	Chain drive configurations with jockey sprockets
147	Request form chain drives
148	Order
148	Details for orders and enquiries for roller chains
149	Details for orders and enquiries for special chains
150	Maintenance of chain drives
151	Shortening and extending of roller chains
152	Chain breakers / Chain pullers
153	Troubleshooting guide for chain drives
156	Contact persons
156	Representations and service centers in Germany
157	Representations worldwide

This catalogue replaces all previous editions. Chain types, which are no longer manufactured due to rationalisation, may still be available or may be manufactured again, if a sufficient quantity is ordered. We reserve the right to alter non-standard chains or cease their production without prior notice.

Illustrations merely serve for exemplification and are by no means binding for the final design. Permissible length deviations according to ISO. For dimensions without stated tolerances DIN ISO 2768 c applies. All information subject to errors and alterations. Any liability for misprints excluded. All rights reserved. No part of this catalogue may be reproduced without prior written permission.

STRONG DRIVE. FOR YOUR SUCCESS

When talking about drive, the first thought that comes to mind are our powerful chains and sprockets or our innovative rigid chain systems, which get many industrial applications moving reliably and sustainably. But we also think of the strong drive that the Wippermann team develops every day in order to create highly efficient drive solutions with passionate commitment. And always with one goal in mind: Your success.



Since 1893
Made in Germany

Innovation meets reliability: Drive technology for demanding industrial processes „Made in Germany“

High temperature, low temperature, contact with water, chemicals or food, dust and abrasive particles as well as many other influences – modern industrial processes place complex demands on the drive systems used. The development and production of powerful industrial chains, sprockets and complete lifting systems for such demanding applications is our core competence. Our engineering services focus in particular on the high requirements for maintenance- and lubricant-free drive components.

For more than 125 years, we have been supporting our customers in optimally setting up their drive technology in a wide range of applications, both economically and technically. Whether production lines, floor conveyors, lifting systems such as scissor lifts or individual special applications: Ultimately, we ensure efficient drive solutions with a design that is perfectly tailored to the respective requirements and of highest quality.

With the close integration of engineering and production at our headquarters in Hagen, we uncompromisingly stand by our philosophy „Made in Germany“. We consistently combine this with our comprehensive expertise from a broad range of industries to effectively support our customers with customized drive solutions in highly competitive markets.

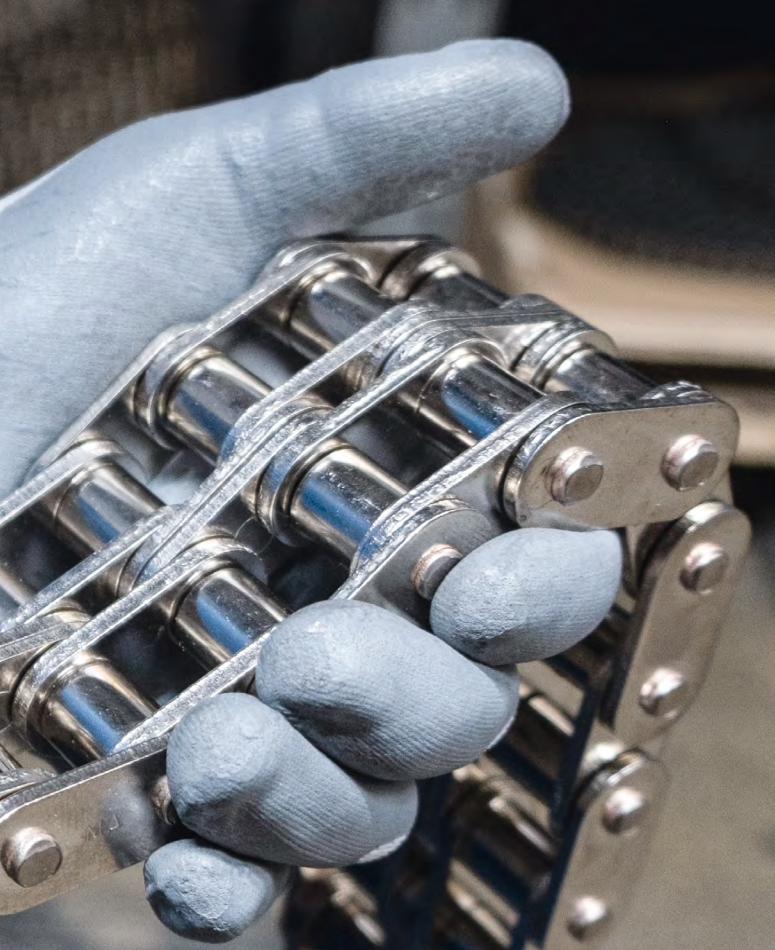

USE INNOVATIONS, EXPAND STRENGTHS: THE RECIPE FOR SUCCESS OF A PROSPEROUS GROUP OF COMPANIES

In many customer projects, individual adaptations are needed to optimally fulfil specific requirements. Therefore, the development of individual drive solutions is one of our daily challenges. Sometimes these are small adaptations, often even completely new developments – our innovative spirit and experience always form the basis for an optimal solution.

One of our greatest strengths is developing standards from innovations, such as our modular concept of maintenance-free and high-performance chains:

This modular system reflects the comprehensive requirements of countless industrial demands: from permanent use under water to dry running operations and FDA approval for food.

Our special performance is also based on the strength of our group of companies: Because we are technically, organizationally and strategically linked to our subsidiary, Wippermann Direkt, Witra, Gevag and our Connex bicycle chain division. For us, innovation is teamwork.

COMPLEX DEMANDS. THIS IS OUR JOB.

We have made our mark worldwide with the development of powerful and economical drive solutions for companies from virtually all industrial sectors. Our customers use this wide-ranging expertise to develop drive solutions in cooperation with us that are optimally tailored to the challenges of their market.

Our industry expertise is based on decades of experience and an enormously broad range of requirements, which we have met over time with continuous new and innovative solutions. In particular, projects that involve diverse, sometimes seemingly contradictory combinations of requirements, we are happy to take as a technical challenge. Because this is where we are particularly strong: in the development of customized solutions for complex tasks in your next project.

Whether in the food or packaging industry, storage and logistics, automotive industry, automation technology or other industries: optimally designed drive, lifting and transport systems are the heartbeat of production. Because without them, literally nothing moves. Maximum reliability, even under extreme conditions, is required here. For example, when used in the food industry, our maintenance-free chains are designed for exposure to water, cleaning or sterilizing agents as well as fats and fatty acids and are FDA compliant. To these and many other similarly complex combinations of requirements in a number of industries, we always have the same answer: this is our job.

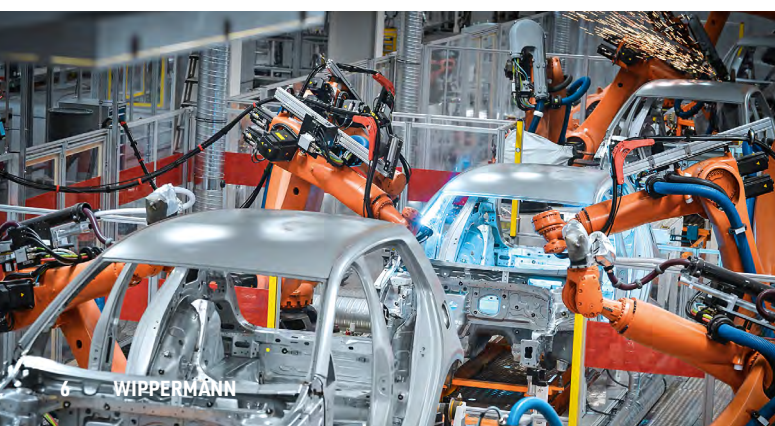



Research and Development

We develop the future: With innovative spirit and state-of-the-art, computer-aided development processes, we are taking the chain drive system to the next level and open up new fields of application.



Product Engineering

With our passion for drive technology and materials, we develop drive solutions with optimum functionality and efficiency for every application, no matter how challenging.



Manufacturing Engineering

Based on our own system know-how, we optimize our machinery for our special requirements. In combination with a high level of added value, this provides us with exceptional manufacturing expertise.



Application Consulting

Thanks to our extensive industry experience we can offer unique application expertise to support our customers in the early stages of their product development.

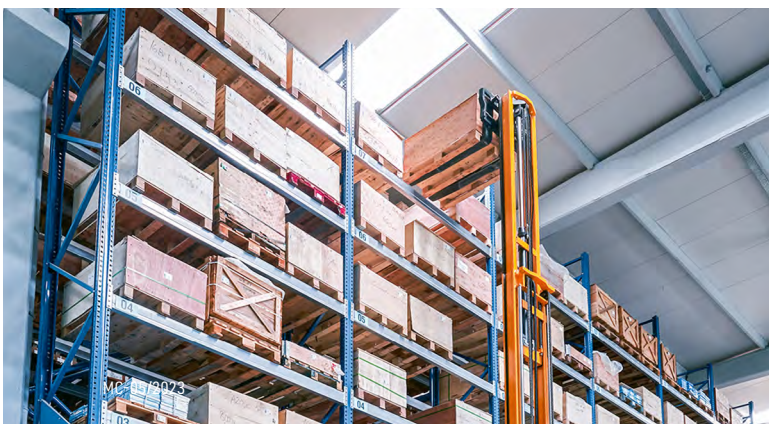

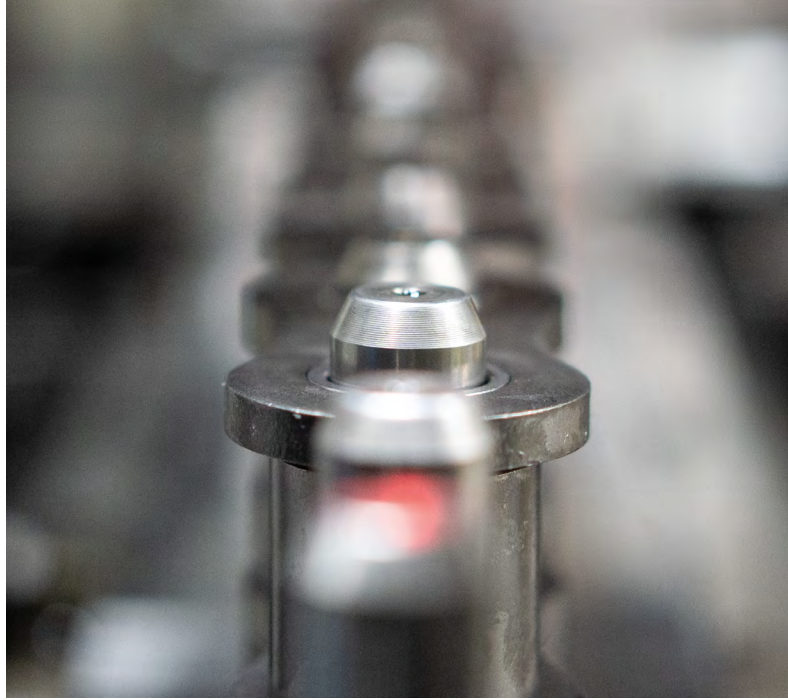

GERMANY

More than 20 distributors
and agencies in Germany



WORLDWIDE

More than 30 international
agencies and partners



Your short route to the right contact person:



wippermann.com/contact-persons

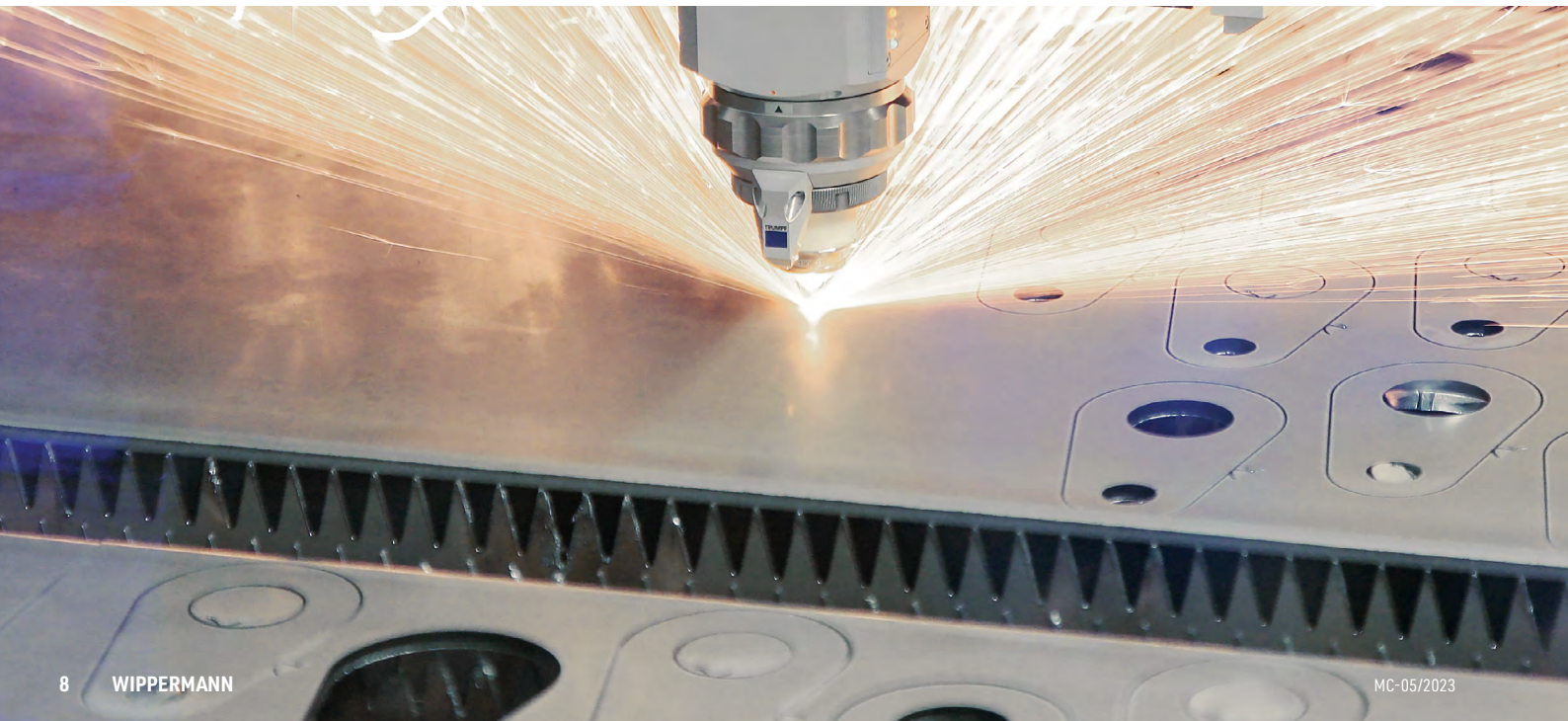

FROM 125 YEARS OF EXPERIENCE WE CREATE THE FUTURE. EVERY DAY ANEW.

Our customers expect more than chains and sprockets of the highest quality. They expect future-proof and sustainable solutions that will also function reliably tomorrow. To this end, we develop and manufacture high-performance drive, conveyor and lifting systems for demanding applications based on the highest quality standards. We ensure our high level of quality through excellent know-how, state-of-the-art technology and comprehensive services. This way our chains and sprockets „Made in Germany“ will continue to be compelling worldwide in the future.

Engineering and manufacturing optimally-coordinated

We offer our customers the opportunity to involve our engineering department in the early planning phases of their projects in order to achieve an optimal design of all components of a drive system for the respective application. In addition, with regard to technical and economic requirements we achieve an extraordinary degree of optimization in the areas of product design and material selection through prototyping.

On this basis, we develop and produce our high-performance chains and sprockets in Germany and work closely with regional suppliers – with partners who share our quality awareness and our sustainability concept. This enables drive systems of uncompromising quality to be created across all engineering and manufacturing stages, proving maximum reliability and durability day after day.

Individual services are our standard

We fulfil our self-image of offering you customized solutions at the highest level as a full-service provider with a broad range of complementary services, which only a manufacturer with a transparent „Made in Germany“ strategy can provide.

Thanks to state-of-the-art laser cutting technology, we offer not only prototyping but also individual small series and the production of sprockets according to customer specifications. If required, we provide you with up-to-date CAD data for your design.

Individual logistics concepts and next day delivery by our Wippermann Direkt service company ensure immediate availability of various parts of our product range. In addition, we provide support with the installation, maintenance and servicing of systems on request, including individual lubricant solutions.

Your fast route to the optimal drive solution:



wippermann.com/your-solution

MAINTENANCE-FREE INDUSTRIAL CHAINS. AN INVESTMENT THAT PAYS OFF.

Maintenance-free industrial chains successfully cover almost any requirement of high-performance drive systems. Our modular system offers you the unique opportunity to customize the components of our high-performance chains to optimally match the performance profile of your requirements.

For decades, we have been committed to advance the new and further development of all kinds of drive components with regard to wear resistance and fatigue strength as well as corrosion-, chemical- and temperature- resistance. By developing selected heavy-duty steels, environmentally-friendly and FDA-compliant functional coatings as well as innovative polymer bearings, we have continuously pushed the technical and economic boundaries.

This results in customized drive solutions for the electrical, food, packaging and automotive industry where lubrication of the chains is not possible for technical or economic reasons.

Our maintenance-free industrial chains are key to maximum efficiency and reliability, making them a safe investment in the cost-effectiveness of your drive technology that will pay off quickly.

Further information about our maintenance-free chains at:



wippermann.com/maintenance-free



As versatile as your application.

The configurable components of our maintenance-free chains offer you various options for the application-specific design of your system. These options include special coatings, sintered bushings containing lubricants and various polymer bearings.

Efficient and sustainable for hoisting applications

The Marathon Lift is the result of consistent customer orientation and now makes the advantages of the maintenance-free operation of our Marathon technology also available for hoisting applications. Engineering by Wippermann and strictly „Made in Germany“.



A NEW LEVEL FOR HOISTING APPLICATIONS. THE MARATHON LIFT.

With the double-patented Marathon Lift we offer our customers a chain-based drive system that takes lifting movements to a new level, thanks to our rigid chain. This means that users can now also benefit from the economic advantages of maintenance-free chains in many industries for demanding hoisting applications.

As a logical continuation of our corporate strategy of developing drive solutions with outstanding performance and efficiency, we have transferred the advantages of the proven Marathon technology to a completely new rigid chain. The U-profile of the outer plate turns the flexible chain into a highly stable outer column during the push or pull phase. Depending on the version, the rigid chain system allows precise and jerk-free lifting of up to two tons to a height of up to two meters. Despite this performance, the Marathon Lift can also be used in very limited installation space, depending on the version.

Sustainable due to maintenance-free operation

Whether deployed in industrial manufacturing processes, car lift systems, scissor lifts, dynamic stages or goods lifts, the double-patented, maintenance-free lifting system is a powerful and economical alternative to hydraulic hoisting solutions. Since the system does not require any operating material such as hydraulic oil or complex lubrication devices, the Marathon Lift also impresses when ecological factors play an important role with regard to sustainability.

Further information about the Marathon Lift at:



wippermann.com/marathon-lift



WITH SPIRIT INTO THE FUTURE. FOR MORE SUSTAINABILITY.

Our future is the result of our actions today. The responsibility for tomorrow lies in our own hands. Assuming responsibility actively applies to every individual in our society and also to us as a company. We face the challenges.

As a family-owned company thinking ahead for generations we ask ourselves how the decisions we make today will affect us tomorrow. We believe that the future requires spirit and thus for Wippermann a wise combination of our commitment to people, the environment and technology.

For us, assuming responsibility as a company means taking care of our employees and the people around us, as well as the environment. Nevertheless, we are also responsible for the future-proof development of our company and thus for continuous technical innovations. Because only a successful and economically sound company can fully meet its obligations towards people and the environment. Today, we summarize this overarching responsibility under the keyword „sustainability“.

For us, it has always been the vision to face the future with spirit.

OUR FOCUS. ON THE PEOPLE.

Clearly, the individuals define and shape our company. Their personality. Their knowledge and skills. And their commitment. Since its foundation, our company has cultivated a corporate culture that pays special attention to the people in the company. This is probably one of the reasons why our employees have been loyal to us for decades and have been with us even for generations.



We are proud of the employee loyalty to our company. And it is an incentive for us to further enhance our attractiveness as an employer. For decades we have continuously focused on qualified training in commercial and industrial professions, in order to offer prospects for young people.

In this context, equal opportunities are an important aspect for us, which in our opinion already begins in the initial phase of professional orientation. By participating in the Girls' and Boys' Day for young students in Germany, we strive to promote equal opportunities at an early stage.

Right from the start of a career, fairness is the basis for successful cooperation in the company. As an employer bound by a collective agreement, we offer fair remuneration and conditions. We value social partnership and operational co-determination, the latter of which is carried out in our company by a works council and the youth and apprentice representation.

For us, occupational safety and health take top priority, because integrity and health are irreplaceable. This is why we are having a comprehensive occupational health and safety management system in place since the 1970s. Today, we comply with the legal regulations and, where it is reasonable, we even exceed them. As part of our health management, we also offer our staff special campaigns such as an annual flu vaccination by our company doctor.

At our company headquarters, we are closely rooted in the region. Not only do most of our employees and suppliers come from the near vicinity, we also focus our community and social commitment locally in our direct area of influence. For example, we support a local sports club and cooperate with regional sheltered workshops, which carry out various jobs for us.

AN ENVIRONMENT WORTH LIVING IN. FOR THE NEXT GENERATION.

Being a company of the steel processing industry, we are one of the energy-intensive enterprises. To this end, we have special responsibility towards the environment, which we actively support. We are continuously working on improving our energy consumption, both in terms of usage efficiency and the mix of energy sources used.

We have our goal of CO₂ neutrality by 2045 clearly in mind. Natural gas, which we use for heat treatment processes in our furnaces, accounts for a large proportion of our CO₂-effective energy mix. This can be substituted with hydrogen in the medium and long term, making this production area CO₂-free. From today's perspective, the bottleneck for this transformation is the sufficient availability of hydrogen at our site.

Since the conversion to hydrogen is planned in the medium and long term, we aim to use energy in the most environmentally friendly way possible. For us, the key factors are using energy multiple times, increasing the efficiency of systems and adapting our energy mix towards renewable energies.

For example, we have been using heat recovery systems on our furnaces in the hardening shop for several years. Energy for our heating system and hot water preparation is generated from hot exhaust gases using heat exchangers.

Heat recovery generates around 400,000 kWh per year, which eliminate the need to generate fossil fuels. This corresponds to a CO₂ saving of 85 tons per year.

Furthermore, we have been able to continuously increase the efficiency of various systems in recent years. In addition to efficient dark radiators, which enable the targeted provision of heat in specific work areas, and the insulation of hall roofs according to current standards, the changeover to energy-saving LED lighting in all areas of the factory have enabled electricity savings of more than 1 million kWh per year. We continuously invest in measures to reduce our energy consumption and the associated emissions.

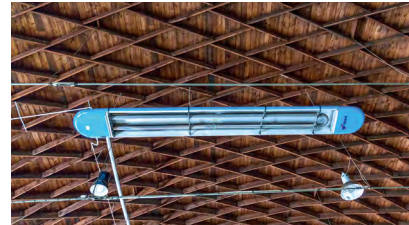



TECHNOLOGICAL INNOVATION. FOR ENVIRONMENTAL PROTECTION.

The future. Nothing less is at stake when we talk about technology. Since innovations also help to protect the environment. Using less harmful materials, saving resources, or providing sustainable solutions that make energy transition possible is what we are striving for every day with all our innovative strength.

Our products have the advantage that the steel they are made of can be fully recycled. Thanks to our engineering expertise, we have developed, among other things, maintenance-free and high-performance chains with special bushings that eliminate the need for re-lubrication of the chain. This saves a significant amount of lubricant. A development entirely in line with the concrete sustainability approach of our product engineering.

We are particularly pleased when our innovations help to advance the energy transition and reduce emissions. Under our Connex bike brand, we have always been producing and selling high-quality bicycle chains. In recent years, we have seen an e-bike boom, which is helping to reduce car usage for short trips, especially in urban areas, thereby reducing emissions locally.

In this market, we supply, among other things, high-quality e-bike chains as OEM to manufacturers as well as to specialist retailers as spare parts for the aftermarket. A special project for us in this context is supplying the chains for the powerful yet compact Ono e-cargo bike from the Berlin tech company Onomotion, which is used for the last mile in the rough everyday delivery business.

And also in production engineering, we are always looking for new ways to make processes more environmentally friendly. In 2023, for example, we installed a closed-loop treatment plant for the process water in the surface technology division. After treatment, the water is fed back into production, drastically reducing water consumption.

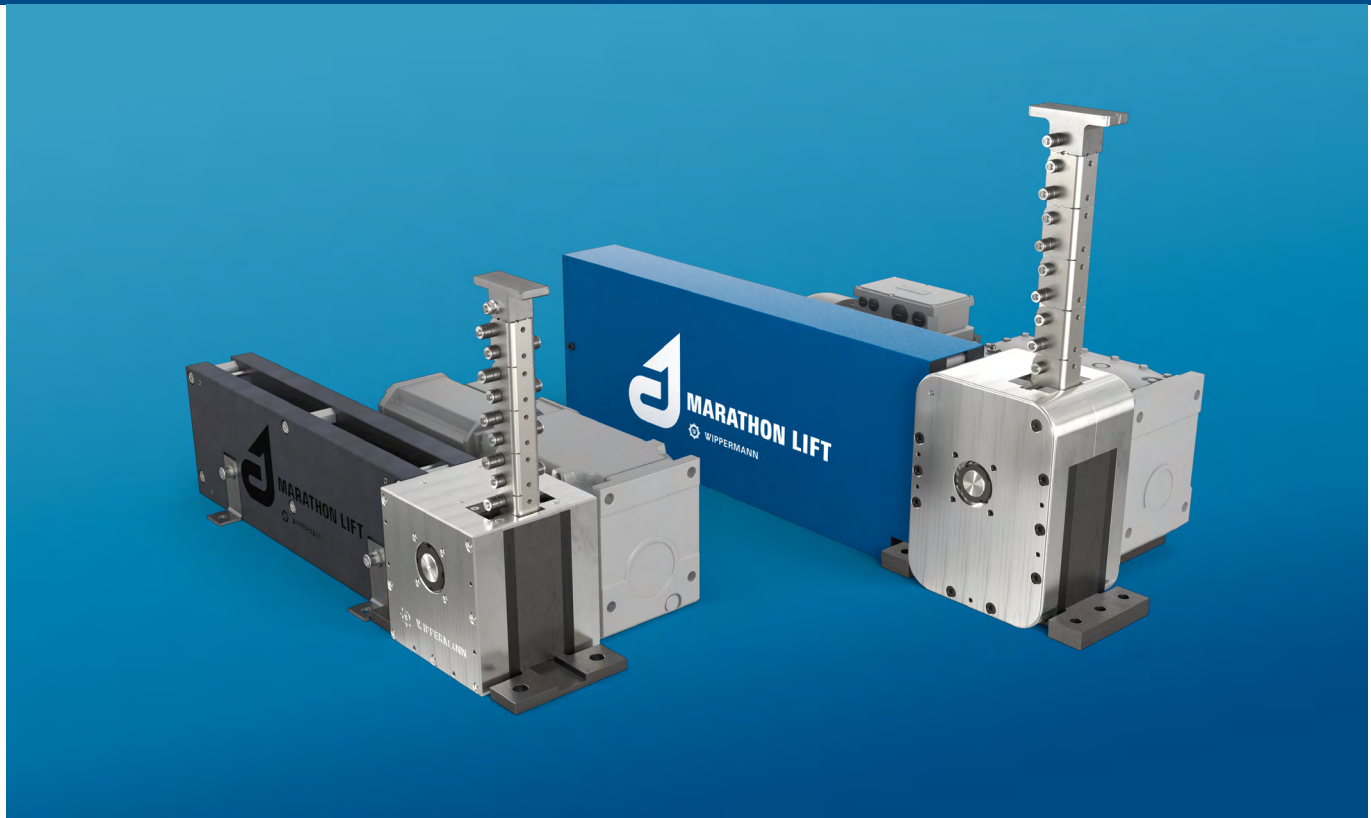

MARATHON LIFT

The maintenance-free rigid chain system for various hoisting and conveyor applications

Thanks to our competence in the segment of maintenance-free industrial chains and sprockets, we have been a valued and respected partner in mechanical and plant engineering for many decades. We have developed the Marathon Lift because we want to offer our customers new possibilities in the field of hoisting and conveyor systems. With this system, we offer you a powerful and particularly economical alternative to traditional hoisting systems on a mechanical, pneumatic or hydraulic basis.

Maintenance-free for optimum cost-effectiveness

The strength of the Marathon Lift is its durability. Maintenance-free and resistant even under permanent high loads with over a million movements - this is the system of choice for manufacturing processes with high demands on reliability and the lowest possible maintenance cycles.

But the Marathon Lift is also convincing from an ecological point of view as it neither requires the operating material needed for hydraulic systems nor complex lubrication systems for comparable chain systems. In addition, rigid chain actuators operate with considerably lower energy consumption than hydraulic systems.

Compact and powerful

The compact design facilitates the integration of the Marathon Lift wherever installation space is limited. In this way, high performance requirements and wear resistance can be combined with difficult spatial parameters. For conditions that are not only found in complex machine and plant construction projects.

The Marathon Lift is available in two sizes. The high-performance model ML2000 allows the precise and jerk-free lifting of loads of up to 2.0 tons to a height of 2.0 meters in just 10 seconds. The construction height of the system is 370 millimeters.

For applications with a load capacity of up to 1.0 tons, we offer the ML1000 - a particularly compact model. Thanks to a total height of just 200 millimeters, the system can be integrated even in very tight installation spaces. The standard lifting height is 1.0 meter. Perfect for use in driverless transport systems.

In both cases, the technical basis of the system is our patented high-performance rigid chain with Marathon technology, which shows no significant wear even after more than one million cycles.

As versatile as your business

Whether industrial manufacturing processes, storage and logistics, dynamic applications in buildings such as vehicle lift systems or stage construction - the Marathon Lift is designed for the specific requirements of a wide range of industries.



Industries and applications

Industrial applications

In complex manufacturing processes such as the automotive industry, the Marathon Lift can be used, among others, as a drive in scissor lifts. In the processing industry, for example, the system can also be used for tool changes in large systems.



Delivery and shipping logistics

The growing freight transport demands flexible loading and unloading systems. Users are, for example, forwarding agencies, airports and other companies with warehouse logistics such as fulfilment providers.



Intralogistics

In addition to transport, intralogistics is another potential area of application to optimize flows of goods within closed systems. Here, the compact Marathon Lift is the perfect addition for the integration into driverless floor conveyors, for example.



Building services engineering and architecture

In inner-city areas, space is scarce and expensive. This makes solutions for space-saving parking all the more important, for example, in underground garages where vehicles have to be moved across several floors. The Marathon Lift allows the implementation of appropriate systems.



Stage and event technology

Opera today, rock concert tomorrow: For the event management industry, a flexible adaptation of the stage is part of everyday life. Movable elements play an important part. Our Marathon Lift will put the largest concert grand piano in the spotlight. The system also allows the implementation of dynamic seating and platform systems in multifunctional halls.



Scissor lifts

Scissor lifts have become indispensable in industrial manufacturing. They ensure that extremely heavy components or entire machines can be aligned vertically in an easy, controlled and precise way.

Thanks to the smart cross-linked control of several units, even dynamic processes can be flexibly controlled on different levels. The innovative rigid chain system ensures a reliable and jerk-free

starting and stopping of the lift tables and the positioning at the target height with millimeter precision.

Due to its compact design, the Marathon Lift offers a significant advantage: The drive module with the compact chain box, motor and gearbox can be installed completely underneath the scissor lift.



Space-saving integration in scissor lifts

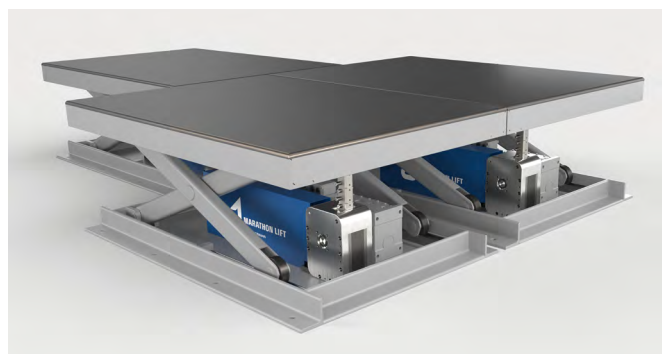

Multi system with cross-linked control



Uncompromising quality through Marathon technology

In the segment of maintenance-free high-performance chains, Wippermann has been setting benchmarks for decades. We achieve this through permanent new and further developments in terms of fatigue strength as well as wear, corrosion and temperature resistance. We work with highly resilient steels as well as environmentally friendly and functional coatings and manufacture our components using state-of-the-art technology.

Our Marathon chain enjoys an excellent reputation in the field of industrial mechanical and plant engineering. The combination of a sintered bushing containing special lubricants and a pin with the strongest wear protection layer on the market allows maintenance-free applications. Its service life is up to 35 times longer compared to a standard roller chain without lubrication. Marathon stands for endurance and top performance.



Proven Marathon technology

An innovative rigid chain is the core of the system

In most cases, hoisting systems are driven by chain or hydraulic drives. While hydraulic systems require a lot of installation space as well as time and cost-intensive maintenance intervals, chain-based systems offer clear advantages. Especially if the chain – as the core of the system – is characterized by an exceptionally high performance.

This is exactly why the Marathon Lift is based on our proven premium product, the Marathon chain. We are convinced: Only a company that can manufacture this chain is able to develop such a powerful system.



Modular design of the Marathon chain

The U makes it unique

The patented Marathon rigid chain has outer plates in the form of a U-profile. During the lifting movement, the flexible chain creates a highly stable outer column which ensures maximum vertical stability by transferring the pressure forces: a unique, strong unit.



Special chains with complex add-on elements for comprehensive transport and conveyor applications have long been part of our product portfolio. Our extensive engineering expertise in this area enabled us to achieve maximum stability and precise positioning even under the highest loads with the Marathon rigid chain thanks to the rigid-backed design.

The support and guide rollers, which are alternately positioned outside the plates, interlock precisely with the special sprockets and thus enable a fast and smooth lifting movement even under heavy loads.

U-shaped outer plate for highest stability during the lifting process



Efficiently driven

Sprockets must be precisely adapted to the driven chain and the particular application. This is prerequisite to minimize wear and to increase the service life. The special sprockets for the Marathon Lift are another proof of our extensive expertise in this area. The special gearing ensures the smooth motion of the system and is therefore as gentle as possible on the drive components of the rigid chain under load.

Patented deflection

The patented deflection system allows the unique interaction between the chain feeding from the chain box without load and the push phase under heavy load. The chain is deflected load-free on specially shaped guide rails and is decoupled from the lifting movement. This reduces wear in the joint and between the U-bolts to a minimum. Moreover, this functional principle ensures an even motion of the chain and thus a jerk-free lifting of the loads.



Our special sprockets with specifically adapted gearing get the system moving. The patented deflection ensures a smooth and even movement.

The perfect fit, even in small spaces

Whatever you intend to move or lift – the Marathon Lift offers high performance with a small footprint. Due to the variety of requirements, we have designed the system in such a way that the various options for chain storage offer a high degree of flexibility and scalability.

Where to store the chain? This is an important question with regard to the available installation space. The storage of the chain in a chain box designed for the specific application enables our customers to realize larger lifting heights with small installation space. If there is sufficient space, however, the chain can also end straight on a rail.

Drive made to measure

The Marathon Lift is designed for easy integration into the respective system for various hoisting and conveyor applications. Within the framework of the usual standards and the technical specifications, our customers can develop individual solutions for the motor or the power transmission of the system or rely on the support of our engineering department.

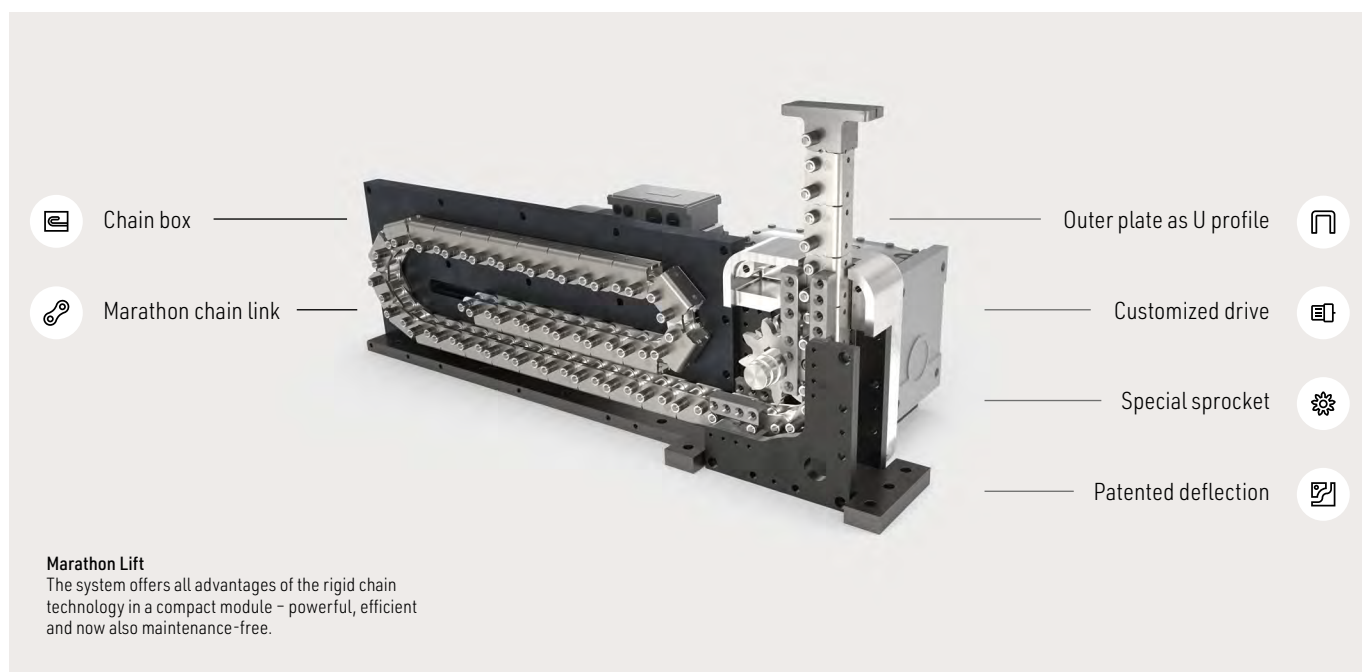



COMPACT, POWERFUL AND RELIABLE: MARATHON LIFT

Convincing lifting solution: Safe compensation of height differences of up to two meters with a load capacity of two tons

Whether as a mobile work table, as a loading and unloading aid for commercial vehicles, as a lifting device for automated floor conveyors or for other manifold applications: Our Marathon Lift models offer a combination of continuous and safe lifting of heavy loads with the advantages of maintenance-free operation and long-term resilience. These features not only provide you with a reliable and flexible lifting solution for compensation of height differences and ergonomic working, but also an extremely economical solution.

In relation to its compact dimensions, the Marathon Lift ML 2000 with a load capacity of 2.0 tons and a lifting height of 2.0 meters offers

exceptional performance that you will appreciate. The Marathon Lift ML 1000 is perfect for applications with extremely limited installation space: With an overall height of only 200 millimeters, this small footprint model is used, for example, in floor conveyors. This extremely small version nevertheless offers a load capacity of 1.0 ton and a standard lifting height of 1 meter.

Should you require further information on optimal lifting solutions, please do not hesitate to contact us. We will be happy to help.

Technical data Marathon Lift ML 1000

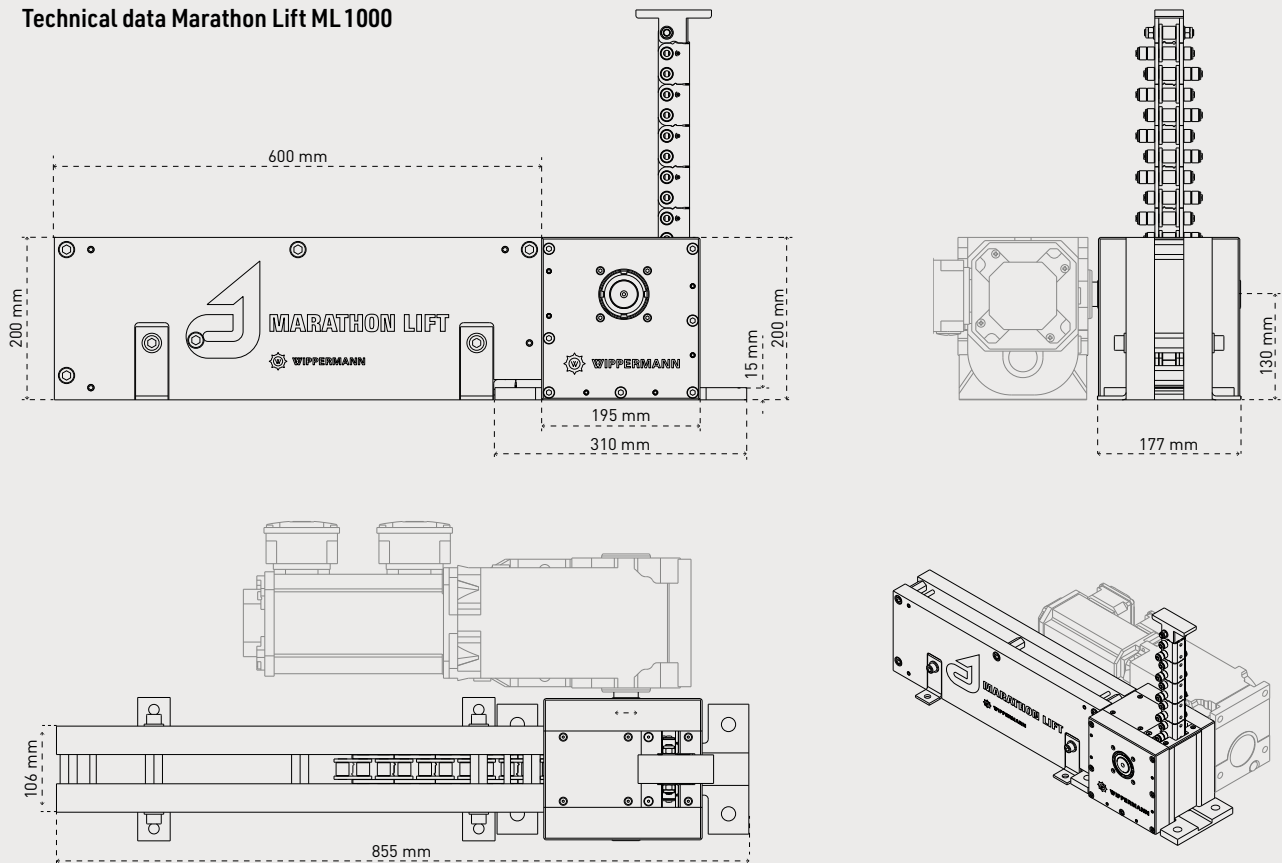

Motor and gear unit not included in delivery.

Application areas: Perfect for applications in very tight installation spaces and for driverless transport systems.

Capacity $F_{\max.}$ (stat.)	20 kN	Chain pitch	1" / 25,4 mm	Total length of system	855 mm
Capacity $F_{\max.}$ (dyn.)	10 kN	Pitch radius of sprocket	53,1 mm	Total height of system	200 mm
Breaking load of chain F_B	72 kN	Chain weight	8 kg/m	Total dimension of rigid chain drive housing (L x B x H)	195 x 106 x 200 mm
Max. load capacity	1,0 t	Conformity	ROHS, REACH	Total dimension of chain box housing (L x B x H)	600 x 177 x 200 mm
Max. unguided lift	1,0 m	Declaration of Incorporation	in accordance with EC Machinery Directive 2006/42/EC, Annex II B	Width of chain box	106 mm
Max. speed	150 mm/s	Patents	No. 10 2016 110 949 No. 10 2016 110 950		
Min. construction height	200 mm				
Min. cycles	> 1.000.000				

Advantages at a glance

- Long-term resilience**
 Even after more than 1.0 million cycles, the rigid chain, the deflection and the sprocket do not exhibit significant wear.
- Exceptional lifting force**
 The rigid chain system lifts heavy loads despite its small construction size.
- Compact design**
 The efficient chain storage allows the system to be deployed even in places where conventional hoisting systems would require too much space.
- Even drive**
 The innovations of our distinct outer plates as well as the patented deflection system ensure smooth lifting and lowering movements and jerk-free starting.
- Precision**
 The lifting system can be moved to any position with millimeter precision without rebounding.
- Low energy consumption**
 Rigid chain actuators operate with considerably lower energy consumption than hydraulic systems.
- Freedom from maintenance**
 Thanks to our maintenance-free high-performance chain, the Marathon Lift can be operated without additional lubrication.

Technical data Marathon Lift ML 2000

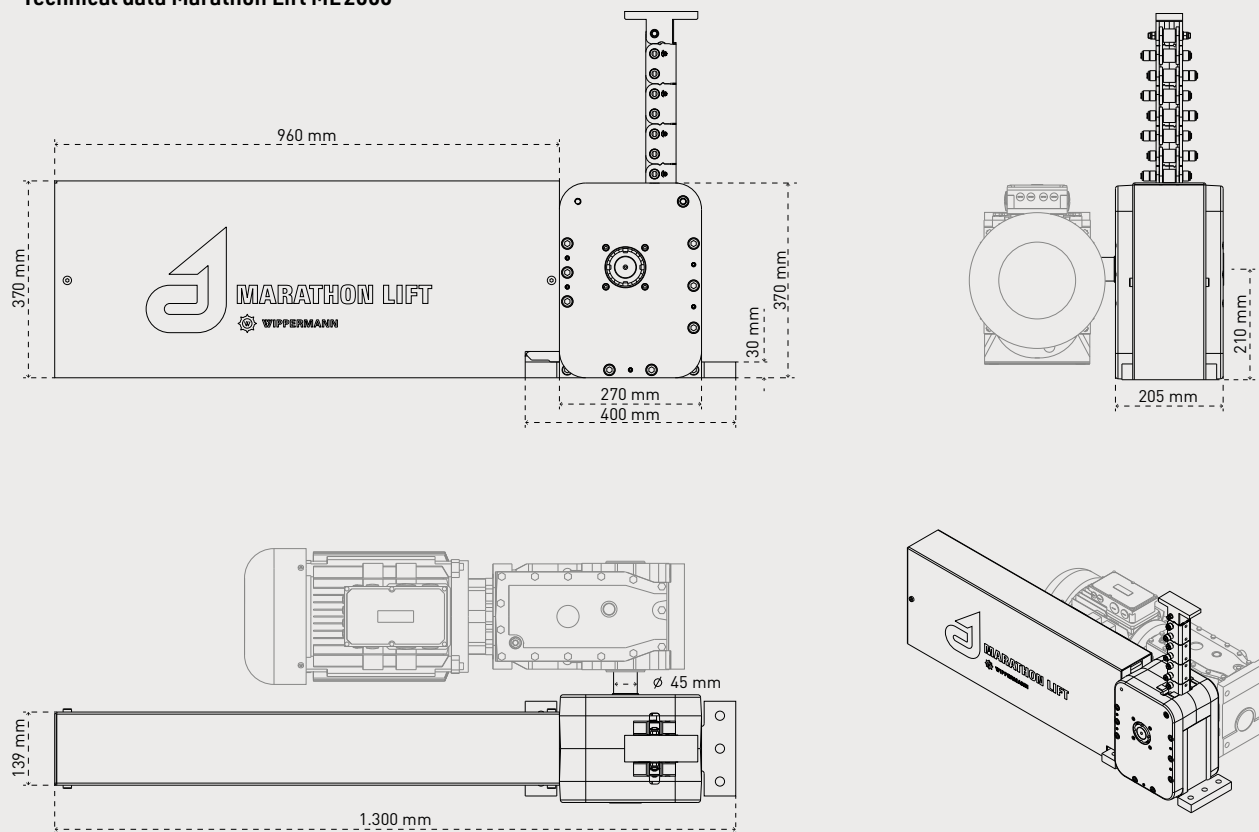

Motor and gear unit not included in delivery.

Application areas: Applications in which large lifting heights have to be achieved with heavy loads (up to 2t) despite limited space, e. g. scissor lifts.

Capacity $F_{max. (stat.)}$	35 kN	Chain pitch	1,5" / 38,1 mm	Total length of system	1.300 mm
Capacity $F_{max. (dyn.)}$	20 kN	Pitch radius of sprocket	54,5 mm	Total height of system	370 mm
Breaking load of chain F_B	140 kN	Chain weight	14 kg/m	Total dimension of rigid chain drive housing (L x B x H)	270 x 139 x 370 mm
Max. load capacity	2,0 t	Conformity	ROHS, REACH	Total dimension of chain box housing (L x B x H)	960 x 205 x 370 mm
Max. unguided lift	2,0 m	Declaration of Incorporation	in accordance with EC Machinery Directive 2006/42/EC, Annex II B	Width of chain box	139 mm
Max. speed	200 mm/s	Patents	No. 10 2016 110 949 No. 10 2016 110 950		
Min. construction height	370 mm				
Min. cycles	> 1.000.000				

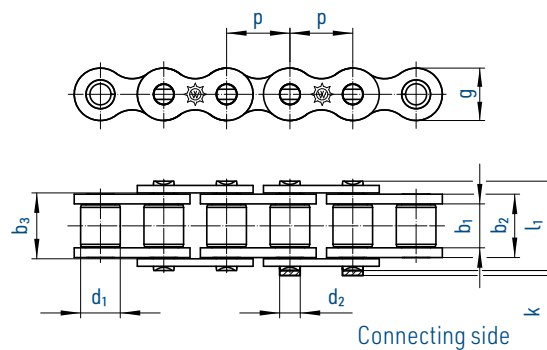

Chain		Pitch	Inner width	Inner link width	Outer plate width	Roller Ø	Pin Ø	Plate height	Projection over connecting link	Width over pin	Bearing area	Breaking load ISO	Brea-king load	Weight	Connecting links		
ISO	p	b ₁ min.	b ₂ max.	b ₃ min.	d ₁ max.	d ₂ max.	g max.	k max.	l ₁ max.	f	F _B min.	F _B min.	q ≈	No.			
No.	Ind.	No.	mm	inch	mm	mm	mm	mm	mm	mm	cm ²	kN	kN	kg/m	No.		
440		03	5,000	-	2,50	4,15	4,25	3,20	1,49	4,1	2,5	7,4	0,06	2,2	2,2	0,08	11,15
445		04	6,000	-	2,80	4,10	4,20	4,00	1,85	5,0	2,9	7,4	0,08	3,0	3,0	0,15	11,15
450		05 B-1	8,000	-	3,00	4,77	4,90	5,00	2,31	7,1	3,1	8,6	0,11	4,4	5,5	0,18	11,15
453		-	9,525	3/8	3,30	5,45	5,58	6,00	2,78	9,0	3,1	9,6	0,15	8,0	8,2	0,26	11,15
454		-	9,525	3/8	3,94	6,70	6,83	6,35	3,28	9,0	3,3	11,6	0,22	9,0	9,4	0,36	11,12,15
455	¹	06 B-1	9,525	3/8	5,72	8,53	8,66	6,35	3,28	8,2	3,3	13,5	0,28	8,9	9,6	0,41	11,12,15
331		081	12,700	1/2	3,30	5,80	5,93	7,75	3,66	9,9	1,5	10,2	0,21	8,0	9,1	0,28	11,12,15
332		-	12,700	1/2	4,88	7,20	7,33	7,75	3,66	9,9	1,5	11,2	0,26	8,2	9,1	0,33	11,12,15
17		083	12,700	1/2	4,88	7,90	8,03	7,75	4,09	10,3	1,5	12,9	0,32	11,6	13,2	0,42	11,12,15
385		-	12,700	1/2	6,40	9,78	9,91	7,75	3,97	11,5	3,9	15,4	0,38	17,1	17,1	0,50	11,12,15
461		-	12,700	1/2	6,40	9,93	10,06	8,51	4,45	11,8	3,9	15,8	0,44	18,0	18,6	0,66	11,12,15
462		08 B-1	12,700	1/2	7,75	11,30	11,43	8,51	4,45	11,8	3,9	17,0	0,50	17,8	18,6	0,70	11,12,15
500		-	15,875	5/8	6,48	10,08	10,21	10,16	5,08	14,7	4,1	16,4	0,51	22,4	27,5	0,78	11,12,15
501		10 B-1	15,875	5/8	9,65	13,28	13,41	10,16	5,08	14,7	4,1	19,6	0,67	22,2	27,0	0,91	11,12,15
513		12 B-1	19,050	3/4	11,68	15,62	15,75	12,07	5,72	16,1	4,6	22,7	0,89	28,9	31,0	1,18	11,12,15
548		16 B-1	25,400	1	17,02	25,40	25,60	15,88	8,28	21,0	5,4	36,1	2,10	60,0	72,0	2,68	11,111,12
552		-	30,000	-	17,02	25,40	25,60	15,88	8,28	21,0	5,4	36,1	2,10	60,0	72,0	2,50	11,111,12
563		20 B-1	31,750	1 1/4	19,56	29,00	29,20	19,05	10,19	26,4	6,1	43,2	2,96	95,0	105,0	3,50	11,111,12
596		24 B-1	38,100	1 1/2	25,40	37,90	38,10	25,40	14,63	33,4	6,6	53,4	5,54	160,0	180,0	6,80	111,12
613		28 B-1	44,450	1 3/4	30,99	46,60	46,70	27,94	15,90	37,0	7,4	65,1	7,39	200,0	230,0	8,50	111,12
652		32 B-1	50,800	2	30,99	45,60	45,70	29,21	17,81	42,3	7,9	67,4	8,10	250,0	276,0	10,50	111,12
671		40 B-1	63,500	2 1/2	38,10	55,70	55,90	39,37	22,89	52,9	10,20	82,6	12,75	355,0	405,0	16,40	111,12
679		48 B-1	76,200	3	45,72	70,50	70,70	48,26	29,24	63,9	10,50	99,1	20,61	560,0	630,0	25,00	111

Electrogalvanised or nickel-plated chains on request. In this case chains may only have 80 % of the tensile strength.

¹ with straight side plates

For details on orders and enquiries see page 148. Standard sprockets as of page 103.
Information on the selection of chain sizes and drives as of page 136.

Connecting links: According to ISO (...)



No. 4 (B)
Inner link



No. 7 (A)
Outer link
(to be riveted)



No. 11 (E)
Spring clip
connecting link



No. 111 (S)
Connecting link
with cottered pin



No. 12 (L)
Single
cranked link



No. 15 (C)
Double
cranked link

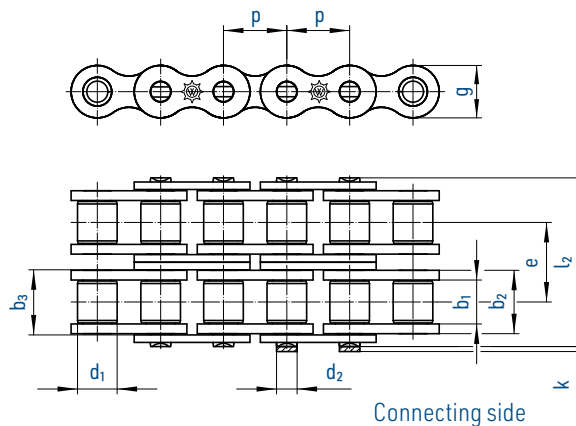

Chain		Pitch	Inner width	Inner link width	Outer plate width	Roller Ø	Pin Ø	Transverse pitch	Plate height	Projection over connecting link	Width over pin	Bearing area	Breaking load ISO	Breaking load	Weight	Connecting links		
No.	Ind.	ISO	p	b ₁ min.	b ₂ max.	b ₃ min.	d ₁ max.	d ₂ max.	e	g max.	k max.	l ₂ max.	f	F _B min.	F _B min.	q ≈	No.	
		No.	mm	inch	mm	mm	mm	mm	mm	mm	mm	mm	cm ²	kN	kN	kg/m	No.	
D 445		-	6,000	-	2,80	4,10	4,25	4,00	1,85	5,50	5,0	2,9	13,3	0,14	5,0	5,0	0,23	11,15
D 450		05 B-2	8,000	-	3,00	4,77	4,90	5,00	2,31	5,64	7,1	3,1	14,3	0,22	7,8	8,2	0,36	11,15
D 455	¹	06 B-2	9,525	3/8	5,72	8,53	8,66	6,35	3,28	10,24	8,2	3,3	23,8	0,56	16,9	17,4	0,86	11,12,15
D 462		08 B-2	12,700	1/2	7,75	11,30	11,43	8,51	4,45	13,92	11,8	3,9	31,0	1,01	31,1	37,0	1,36	11,12,15
D 501		10 B-2	15,875	5/8	9,65	13,28	13,41	10,16	5,08	16,59	14,7	4,1	36,2	1,34	44,5	54,0	1,82	11,12,15
D 513		12 B-2	19,050	3/4	11,68	15,62	15,75	12,07	5,72	19,46	16,1	4,6	42,2	1,79	57,8	63,0	2,38	11,12,15
D 548		16 B-2	25,400	1	17,02	25,40	25,60	15,88	8,28	31,88	21,0	5,4	68,0	4,21	106,0	140,0	5,30	11,111,12
D 563		20 B-2	31,750	1 1/4	19,56	29,00	29,20	19,05	10,19	36,45	26,4	6,1	79,7	5,91	170,0	210,0	7,30	11,111,12
D 596		24 B-2	38,100	1 1/2	25,40	37,90	38,10	25,40	14,63	48,36	33,4	6,6	101,8	11,09	280,0	360,0	13,40	111,12
D 613		28 B-2	44,450	1 3/4	30,99	46,60	46,70	27,94	15,90	59,56	37,0	7,4	124,7	14,79	360,0	443,0	16,60	111,12
D 652		32 B-2	50,800	2	30,99	45,60	45,70	29,21	17,81	58,55	42,3	7,9	126,0	16,21	450,0	530,0	21,00	111,12
D 671		40 B-2	63,500	2 1/2	38,10	55,70	55,90	39,37	22,89	72,29	52,9	10,2	154,9	25,50	630,0	806,0	32,60	111,12
D 679		48 B-2	76,200	3	45,72	70,50	70,70	48,26	29,24	91,21	63,9	10,5	190,4	41,23	1000,0	1100,0	50,00	111

Electrogalvanised or nickel-plated chains on request. In this case chains may only have 80 % of the tensile strength.

¹ with straight side plates

For details on orders and enquiries see page 148. Standard sprockets as of page 103. Information on the selection of chain sizes and drives as of page 136.

Connecting links: According to ISO (...)



No. 4 (B)
Inner link



No. 7 (A)
Outer link
(to be riveted)



No. 11 (E)
Spring clip
connecting link



No. 111 (S)
Connecting link with
cottered pin



No. 12 (L)
Single
cranked link



No. 15 (C)
Double
cranked link

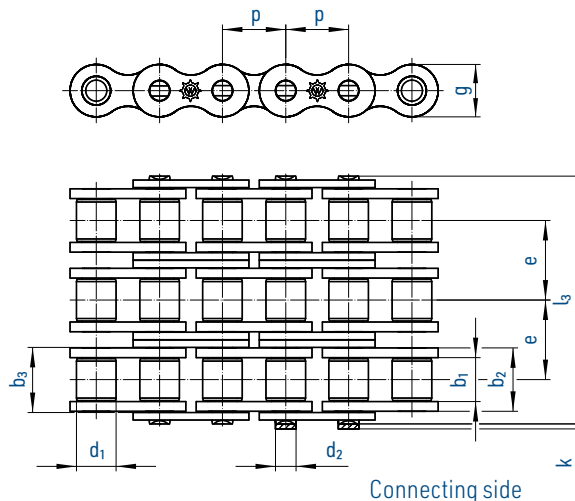
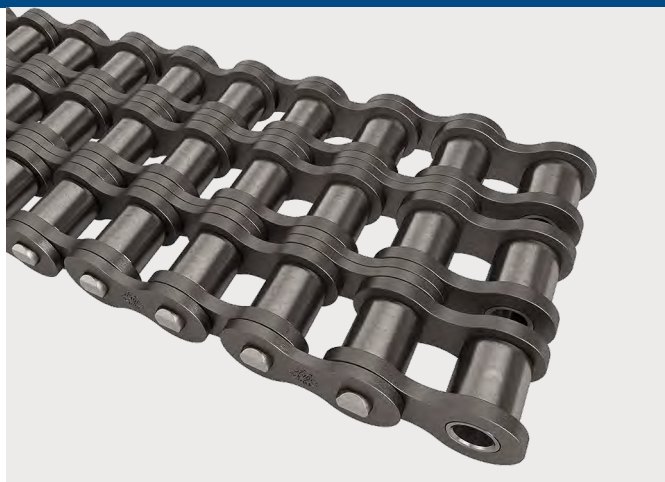

Chain		Pitch	Inner width	Inner link width	Outer plate width	Roller Ø	Pin Ø	Transverse pitch	Plate height	Projection over connecting link	Width over pin	Bearing area	Breaking load ISO	Breaking load	Weight	Connecting links		
	ISO	p	b ₁ min.	b ₂ max.	b ₃ min.	d ₁ max.	d ₂ max.	e	g max.	k max.	l ₃ max.	f	F _B min.	F _B min.	q ≈	No.		
No.	Ind.	No.	mm	inch	mm	mm	mm	mm	mm	mm	mm	cm ²	kN	kN	kg/m	No.		
T 450		05 B-3	8,000		3,00	4,77	4,90	5,00	2,31	5,64	7,1	3,1	19,9	0,33	11,1	11,1	0,54	11,15
T 455	¹	06 B-3	9,525	³ / ₈	5,72	8,53	8,66	6,35	3,28	10,24	8,2	3,3	34,0	0,81	24,9	24,9	1,18	11,12,15
T 462		08 B-3	12,700	¹ / ₂	7,75	11,30	11,43	8,51	4,45	13,92	11,8	3,9	44,9	1,51	44,5	56,0	2,01	11,12,15
T 501		10 B-3	15,875	⁵ / ₈	9,65	13,28	13,41	10,16	5,08	16,59	14,7	4,1	52,8	2,02	66,7	80,0	2,70	11,12,15
T 513		12 B-3	19,050	³ / ₄	11,68	15,62	15,75	12,07	5,72	19,46	16,1	4,6	61,7	2,68	86,7	94,0	3,12	11,12,15
T 548		16 B-3	25,400	1	17,02	25,40	25,60	15,88	8,28	31,88	21,0	5,4	99,9	6,31	160,0	211,0	7,50	11,111,12
T 563		20 B-3	31,750	1 ¹ / ₄	19,56	29,00	29,20	19,05	10,19	36,45	26,4	6,1	116,1	8,87	250,0	300,0	10,60	11,111,12
T 596		24 B-3	38,100	1 ¹ / ₂	25,40	37,90	38,10	25,40	14,63	48,36	33,4	6,6	150,2	16,63	425,0	523,0	20,00	111,12
T 613		28 B-3	44,450	1 ³ / ₄	30,99	46,60	46,70	27,94	15,90	59,56	37,0	7,4	184,3	22,18	530,0	660,0	25,00	111,12
T 652		32 B-3	50,800	2	30,99	45,60	45,70	29,21	17,81	58,55	42,3	7,9	184,5	24,31	670,0	800,0	32,00	111,12
T 671		40 B-3	63,500	2 ¹ / ₂	38,10	55,70	55,90	39,37	22,89	72,29	52,9	10,2	227,2	38,25	950,0	1140,0	48,70	111,12
T 679		48 B-3	76,200	3	45,72	70,50	70,70	48,26	29,24	91,21	63,9	10,5	281,6	61,84	1500,0	1720,0	75,00	111

Electrogalvanised or nickel-plated chains on request. In this case chains may only have 80 % of the tensile strength.

¹ with straight side plates

For details on orders and enquiries see page 148. Standard sprockets as of page 103. Information on the selection of chain sizes and drives as of page 136.

Connecting links: According to ISO (...)



No. 4 (B)
Inner link



No. 7 (A)
Outer link
(to be riveted)



No. 11 (E)
Spring clip
connecting link



No. 111 (S)
Connecting link
with cottered pin



No. 12 (L)
Single
cranked link



No. 15 (C)
Double
cranked link

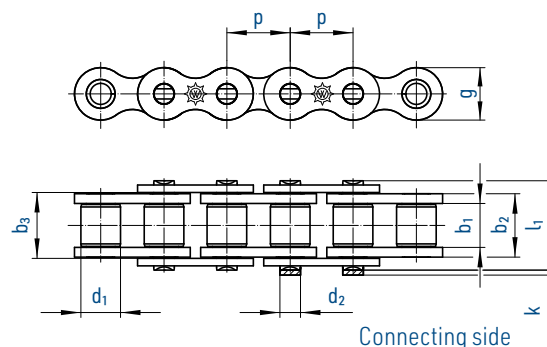
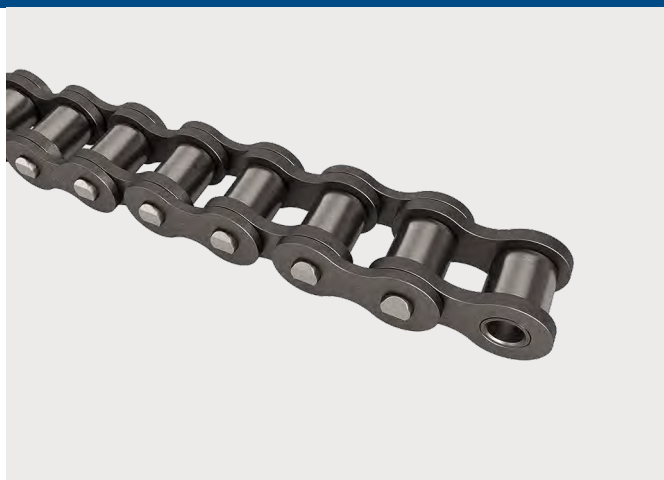

Chain		Pitch	Inner width	Inner link width	Outer plate width	Roller Ø	Pin Ø	Plate height	Projection over connecting link	Width over pin	Bearing area	Breaking load ISO	Breaking load	Weight	Connecting links		
ISO	p	b ₁ min.	b ₂ max.	b ₃ min.	d ₁ max.	d ₂ max.	g max.	k max.	l ₁ max.	f	F _B min.	F _B min.	q ≈	No.			
No.	Ind.	No.	mm	inch	mm	mm	mm	mm	mm	mm	mm	cm ²	kN	kN	kg/m	No.	
25	²	04 C-1	6,350	1/4	3,10	4,80	4,85	3,30	2,31	6,0	2,5	9,1	0,11	3,5	3,5	0,13	11,15
35	²	06 C-1	9,525	3/8	4,68	7,46	7,52	5,08	3,60	9,1	3,3	13,2	0,27	7,9	10,2	0,35	11,12,15
40		08 A-1	12,700	1/2	7,85	11,17	11,23	7,92	3,98	12,0	3,9	17,8	0,44	13,9	16,5	0,60	11,12,15
50		10 A-1	15,875	5/8	9,40	13,84	13,90	10,16	5,09	15,1	4,1	21,8	0,70	21,8	30,0	1,01	11,12,15
60	⁹	12 A-1	19,050	3/4	12,57	17,75	17,81	11,91	5,96	18,1	4,6	26,9	1,05	31,3	40,0	1,58	11,111,12,15
80	⁹	16 A-1	25,400	1	15,75	22,60	22,66	15,88	7,94	24,1	5,4	33,5	1,78	55,6	69,0	2,36	11,111,12
100	⁹	20 A-1	31,750	1 1/4	18,90	27,45	27,51	19,05	9,54	30,2	6,1	41,1	2,61	87,0	92,5	3,80	111,12
120	⁹	24 A-1	38,100	1 1/2	25,22	35,45	35,51	22,23	11,11	36,2	6,6	50,8	3,92	125,0	139,0	5,40	111,12
140	⁹	28 A-1	44,450	1 3/4	25,22	37,18	37,24	25,40	12,71	42,2	7,4	54,9	4,70	170,0	178,5	7,30	111,12
160	⁹	32 A-1	50,800	2	31,55	45,21	45,26	28,58	14,29	48,2	7,9	65,5	6,42	223,0	231,0	9,90	111,12
200	⁹	40 A-1	63,500	2 1/2	37,85	54,88	54,94	39,68	19,85	60,3	10,2	80,3	10,85	347,0	387,0	16,50	111,12

Heavy duty design with reinforced side plates and enlarged bearing areas

50 H		-	15,875	5/8	9,40	14,60	14,73	10,16	5,08	15,0	4,1	23,4	0,75	22,2	32,0	1,18	11
60 H	⁹	-	19,050	3/4	12,57	19,43	19,48	11,91	5,96	18,1	4,6	30,2	1,16	31,3	42,0	1,94	11
80 H	⁹	-	25,400	1	15,75	24,28	24,33	15,88	7,94	24,1	5,4	37,4	1,92	55,6	72,0	3,04	111
100 H	⁹	-	31,750	1 1/4	18,90	29,10	29,16	19,05	9,54	30,1	6,1	44,5	2,77	87,0	96,0	4,25	111
120 H	⁹	-	38,100	1 1/2	25,22	37,18	37,24	22,23	11,11	36,2	6,6	55,0	4,13	125,0	141,0	6,40	111
140 H	⁹	-	44,450	1 3/4	25,22	38,86	38,91	25,40	12,71	42,2	7,4	59,0	4,94	170,0	180,0	8,30	111
160 H	⁹	-	50,800	2	31,55	46,88	46,94	28,58	14,29	48,2	7,9	69,4	6,70	223,0	233,0	11,50	111
200 H	⁹	-	63,500	2 1/2	37,85	58,29	58,34	39,68	19,85	60,3	10,2	87,1	11,60	347,0	400,0	20,00	111

Electrogalvanised or nickel-plated chains on request. In this case chains may only have 80 % of the tensile strength.

² without rollers ⁹ dismantlable (splinted) design on request

For details on orders and enquiries see page 148. Standard sprockets as of page 103.
Information on the selection of chain sizes and drives as of page 136.

Connecting links: According to ISO (...)



No. 4 (B)
Inner link

No. 7 (A)
Outer link
(to be riveted)

No. 11 (E)
Spring clip
connecting link

No. 111 (S)
Connecting link
with cottered pin

No. 12 (L)
Single
cranked link

No. 15 (C)
Double
cranked link

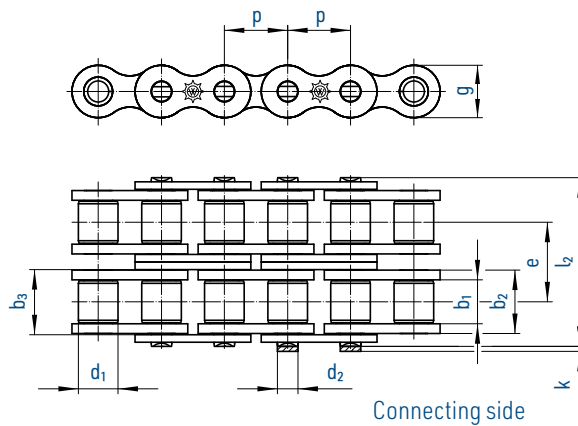

Chain		Pitch	Inner width	Inner link width	Outer plate width	Roller Ø	Pin Ø	Transverse pitch	Plate height	Projection over connecting link	Width over pin	Bearing area	Breaking load ISO	Breaking load	Weight	Connecting links		
No.	Ind.	ISO	p		b ₁ min.	b ₂ max.	b ₃ min.	d ₁ max.	d ₂ max.	e	g max.	k max.	l ₂ max.	f	F _B min.	F _B min.	q ≈	No.
		No.	mm	inch	mm	mm	mm	mm	mm	mm	mm	mm	mm	cm ²	kN	kN	kg/m	No.
40-2		08 A-2	12,700	1/2	7,85	11,17	11,23	7,92	3,98	14,38	12,0	3,9	32,3	0,88	27,8	29,7	1,20	11,12,15
50-2		10 A-2	15,875	5/8	9,40	13,84	13,90	10,16	5,09	18,11	15,1	4,1	39,9	1,40	43,6	62,0	1,78	11,12,15
60-2	°	12 A-2	19,050	3/4	12,57	17,75	17,81	11,91	5,96	22,78	18,1	4,6	49,8	2,10	62,6	76,0	3,15	11,111,12,15
80-2	°	16 A-2	25,400	1	15,75	22,60	22,66	15,88	7,94	29,29	24,1	5,4	62,7	3,56	111,2	135,0	4,90	11,111,12,15
100-2	°	20 A-2	31,750	1 1/4	18,90	27,45	27,51	19,05	9,54	35,76	30,2	6,1	77,0	5,22	174,0	205,0	7,60	111,12
120-2	°	24 A-2	38,100	1 1/2	25,22	35,45	35,51	22,23	11,11	45,44	36,2	6,6	96,3	7,84	250,0	290,0	10,80	111,12
140-2	°	28 A-2	44,450	1 3/4	25,22	37,18	37,24	25,40	12,71	48,87	42,2	7,4	106,3	9,40	340,0	357,0	14,30	111,12
160-2	°	32 A-2	50,800	2	31,55	45,21	45,26	28,58	14,29	58,55	48,2	7,9	124,2	12,84	446,0	455,0	19,40	111,12
200-2	°	40 A-2	63,500	2 1/2	37,85	54,88	54,94	39,68	19,85	71,55	60,3	10,2	151,9	21,70	694,0	730,0	33,00	111,12

Electrogalvanised or nickel-plated chains on request. In this case chains may only have 80 % of the tensile strength.

° dismantlable (splinted) design on request

For details on orders and enquiries see page 148. Sprockets on request.
Information on the selection of chain sizes and drives as of page 136.

Connecting links: According to ISO (...)



No. 4 (B)
Inner link



No. 7 (A)
Outer link
(to be riveted)



No. 11 (E)
Spring clip
connecting link



No. 111 (S)
Connecting link
with cottered pin



No. 12 (L)
Single
cranked link



No. 15 (C)
Double
cranked link

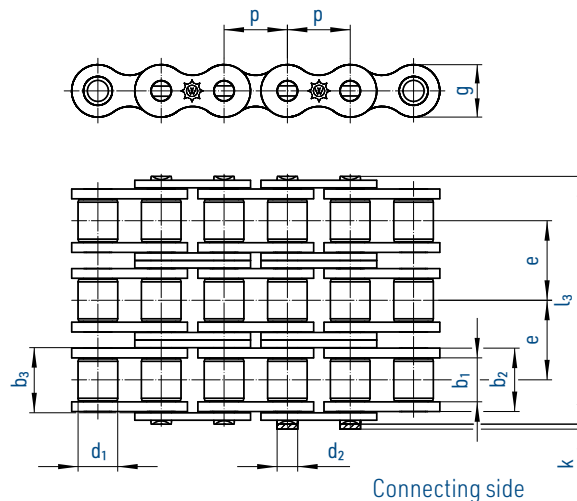
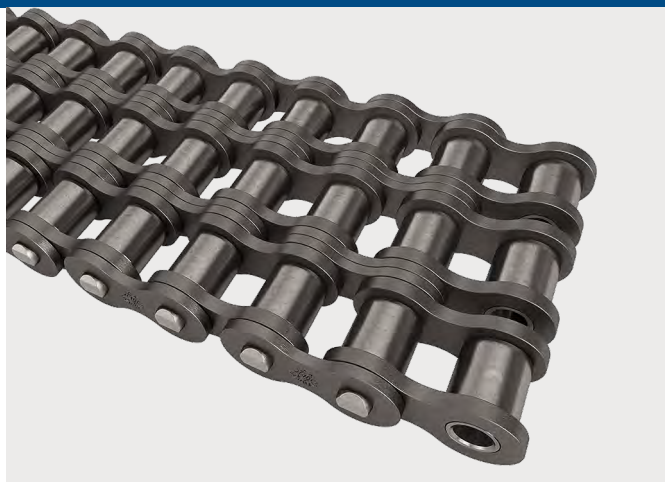

Chain		Pitch	Inner width	Inner link width	Outer plate width	Roller Ø	Pin Ø	Transverse pitch	Plate height	Projection over connecting link	Width over pin	Bearing area	Breaking load ISO	Breaking load	Weight	Connecting links		
No.	Ind.	ISO	p		b ₁ min.	b ₂ max.	b ₃ min.	d ₁ max.	d ₂ max.	e	g max.	k max.	l ₃ max.	f	F _B min.	F _B min.	q ≈	No.
		No.	mm	inch	mm	mm	mm	mm	mm	mm	mm	mm	mm	mm	cm ²	kN	kN	kg/m
40-3		08 A-3	12,700	1/2	7,85	11,17	11,23	7,92	3,98	14,38	12,0	3,9	46,7	1,32	41,7	41,2	1,80	11,12,15
50-3		10 A-3	15,875	5/8	9,40	13,84	13,90	10,16	5,09	18,11	15,1	4,1	57,9	2,10	65,4	88,0	3,02	11,12,15
60-3	°	12 A-3	19,050	3/4	12,57	17,75	17,81	11,91	5,96	22,78	18,1	4,6	72,6	3,15	93,9	105,0	4,70	11,111,12,15
80-3	°	16 A-3	25,400	1	15,75	22,60	22,66	15,88	7,94	29,29	24,1	5,4	91,9	5,35	166,8	193,0	7,50	11,111,12,15
100-3	°	20 A-3	31,750	1 1/4	18,90	27,45	27,51	19,05	9,54	35,76	30,2	6,1	113,0	7,83	261,0	305,0	11,20	111,12
120-3	°	24 A-3	38,100	1 1/2	25,22	35,45	35,51	22,23	11,11	45,44	36,2	6,6	141,7	11,76	375,0	410,0	16,10	111,12
140-3	°	28 A-3	44,450	1 3/4	25,22	37,18	37,24	25,40	12,71	48,87	42,2	7,4	152,4	14,10	510,0	520,0	21,40	111,12
160-3	°	32 A-3	50,800	2	31,55	45,21	45,28	28,58	14,29	58,55	48,2	7,9	182,9	19,26	669,0	685,0	29,10	111,12
200-3	°	40 A-3	63,500	2 1/2	37,85	54,88	54,94	39,68	19,85	71,55	60,3	10,2	223,5	32,56	1041,0	1095,0	50,00	111,12

Electrogalvanised or nickel-plated chains on request. In this case chains may only have 80 % of the tensile strength.

° dismantlable (splinted) design on request

For details on orders and enquiries see page 148. Sprockets on request.
Information on the selection of chain sizes and drives as of page 136.

Connecting links: According to ISO (...)



No. 4 (B)
Inner link



No. 7 (A)
Outer link
(to be riveted)



No. 11 (E)
Spring clip
connecting link



No. 111 (S)
Connecting link
with cottered pin



No. 12 (L)
Single
cranked link



No. 15 (C)
Double
cranked link



Simplex chains

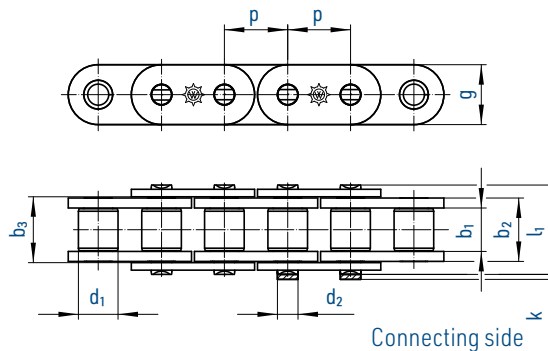

Connecting side

Duplex chains

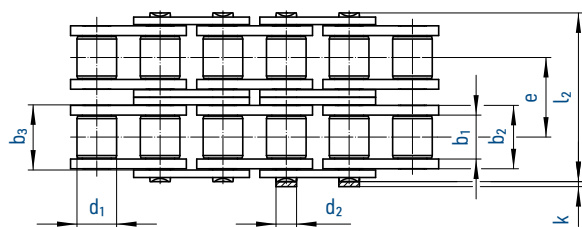

Connecting side

Triplex chains

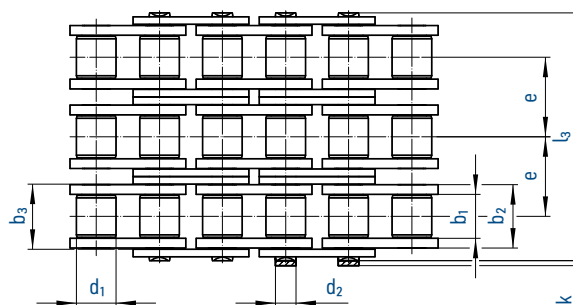

Connecting side

Chain		Pitch		Inner width	Inner link width	Outer plate width	Roller Ø	Pin Ø	Transverse pitch	Plate height	Projection over connecting link	Width over pin	Bearing area	Bearing load ISO	Bearing load	Weight	Connecting links
No.		mm	inch	b ₁ min.	b ₂ max.	b ₃ min.	d ₁ max.	d ₂ max.	e	g max.	k max.	l max.	f	F _B min.	F _B min.	q ≈	No.
455 GL		9,525	3/8	5,72	8,53	8,66	6,35	3,28	-	8,2	3,3	13,5	0,28	8,9	9,6	0,41	4,7,11,12,15
462 GL		12,700	1/2	7,75	11,30	11,43	8,51	4,45	-	11,5	3,9	17,0	0,50	17,8	18,6	0,78	4,7,11,12
501 GL		15,875	5/8	9,65	13,28	13,41	10,16	5,08	-	14,2	4,1	19,6	0,67	22,2	27,0	1,03	4,7,11
513 GL		19,050	3/4	11,68	15,62	15,75	12,07	5,72	-	15,5	4,6	22,7	0,89	28,9	31,0	1,29	4,7,11,12
60 GL		19,050	3/4	12,57	17,70	17,85	11,91	5,94	-	18,0	4,6	26,9	1,05	31,3	41,0	1,58	4,7,11
60 HGL		19,050	3/4	12,57	19,45	19,60	11,91	5,94	-	18,0	4,6	28,9	1,16	31,3	41,0	1,94	4,7,11
548 GL		25,400	1	17,02	25,40	25,60	15,88	8,28	-	24,0	5,4	36,1	2,10	60,0	72,0	3,29	4,7,11
548 GLS		25,400	1	17,02	25,40	25,60	15,88	8,28	-	21,0	5,4	36,1	2,10	60,0	72,0	2,90	4,7,11,12
563 GL	¹⁰	31,750	1 1/4	19,56	29,00	29,20	19,05	10,19	-	26,4	6,1	43,2	2,95	95,0	105,0	4,13	4,7,11,12
596 GL		38,100	1 1/2	25,40	37,90	38,10	25,4	14,63	-	33,4	6,6	53,4	5,54	160,0	180,0	7,34	4,7,11,12
455 GL-2		9,525	3/8	5,72	8,53	8,66	6,35	3,28	10,24	8,2	3,3	23,8	0,56	16,9	17,4	0,86	4,7,11,12,15
462 GL-2		12,700	1/2	7,75	11,30	11,43	8,51	4,45	13,92	11,5	3,9	31,0	1,01	31,1	37,0	1,50	4,7,11,12
501 GL-2		15,875	5/8	9,65	13,28	13,41	10,16	5,08	16,59	14,2	4,1	36,2	1,34	44,5	54,0	2,00	4,7,11
513 GL-2		19,050	3/4	11,68	15,62	15,75	12,07	5,72	19,46	15,5	4,6	42,2	1,79	57,8	63,0	2,62	4,7,11,12
60 GL-2		19,050	3/4	12,57	17,70	17,85	11,91	5,94	22,78	18,0	4,6	49,8	2,10	62,6	76,0	3,08	4,7,11
548 GL-2		25,400	1	17,02	25,40	25,60	15,88	8,28	31,88	24,0	5,4	68,0	4,21	106,0	140,0	6,59	4,7,11
548 GLS-2		25,400	1	17,02	25,40	25,60	15,88	8,28	31,88	21,0	5,4	68,0	4,21	106,0	140,0	5,85	4,7,11
563 GL-2	¹⁰	31,750	1 1/4	19,56	29,00	29,20	19,05	10,19	36,45	26,4	6,1	79,7	5,91	170,0	210,0	8,03	4,7,11,12
596 GL-2		38,100	1 1/2	25,40	37,92	38,10	25,4	14,63	48,36	33,4	6,6	101,8	11,09	280,0	360,0	14,47	4,7,11,12
455 GL-3		9,525	3/8	5,72	8,53	8,66	6,35	3,28	10,24	8,2	3,3	34,0	0,81	24,9	24,9	1,30	4,7,11,12,15
462 GL-3		12,700	1/2	7,75	11,30	11,43	8,51	4,45	13,92	11,5	3,9	44,9	1,51	44,5	56,0	2,21	4,7,11,12
501 GL-3		15,875	5/8	9,65	13,28	13,41	10,16	5,08	16,59	14,2	4,1	52,8	2,02	66,7	80,0	2,97	4,7,11
513 GL-3		19,050	3/4	11,68	15,62	15,75	12,07	5,72	19,46	15,5	4,6	61,7	2,68	86,7	94,0	3,43	4,7,11,12
60 GL-3		19,050	3/4	12,57	17,70	17,85	11,91	5,94	22,78	18,0	4,6	72,6	3,15	93,9	105,0	4,58	4,7,11
548 GL-3		25,400	1	17,02	25,40	25,60	15,88	8,28	31,88	24,0	5,4	99,9	6,31	160,0	211,0	9,88	4,7,11
548 GLS-3		25,400	1	17,02	25,40	25,60	15,88	8,28	31,88	21,0	5,4	99,9	6,31	160,0	211,0	8,50	4,7,11
563 GL-3	¹⁰	31,750	1 1/4	19,56	29,00	29,20	19,05	10,19	36,45	26,4	6,1	116,1	8,87	250,0	300,0	11,66	4,7,11,12
596 GL-3		38,100	1 1/2	25,40	37,90	38,10	25,40	14,63	48,36	33,4	6,6	150,2	16,63	425,0	523,0	22,00	4,7,11,12

Electrogalvanised or nickel-plated chains on request. In this case chains may only have 80 % of the tensile strength.

¹⁰ also in stainless steel available

For details on orders and enquiries see page 148. Standard sprockets as of page 103. Information on the selection of chain sizes and drives as of page 136.

MAINTENANCE-FREE HIGH-PERFORMANCE CHAINS BY THE MARKET LEADER

Individually configurable drive solutions for special requirements

Our concept for maintenance-free high-performance chains is modularity: Components with various properties allow the configuration of the chain according to your requirements. For customized drive solutions with optimum performance.

In many industrial applications, lubrication of chains is not possible for technical or economic reasons. In addition, there are often special requirements such as high temperatures or contact with water, steam, chemicals or food.

We offer sophisticated solutions for these: For decades, we have been committed to continuously advancing the new and further development of all kinds of drive components with regard to wear resistance and fatigue strength as well as corrosion-, chemical- and temperature-resistance. By developing selected heavy-duty steels, environmentally-friendly functional coatings as well as innovative FDA-compliant polymer bearings we have continuously pushed the technical and economic boundaries.

Today, a broad range of low-maintenance and maintenance-free industrial chains by Wippermann meet virtually all requirements placed upon drive systems.

Our six high-performance models are perfectly designed for the most important combinations of the most common industrial demands. Furthermore, if you have an application with a very special combination of requirements, we will be happy to help you with our extensive experience: If necessary, we adapt our maintenance-free chains to your specific requirements so that you are provided with an optimal, maintenance-free drive solution.

Adjusted to technical and economical perfection

Our maintenance-free chains comprise a broad range of applications. The interaction of the components leads to a unique performance profile for each chain model. The result: tailor-made drive solutions for the electrical, food, packaging and automotive industry where lubrication of the chains is not possible due to technical or economic reasons..

maintenance-free	TRIATHLON	TRIATHLON KS	MARATHON RF	lubricant-free
	MARATHON	-	-	
low-maintenance	BIATHLON	BIATHLON KS	BIATHLON RF*	lubricated
high-maintenance	STANDARD	STANDARD KS	STANDARD RF	
	unprotected	corrosion-protected	corrosion-free	

KS corrosion protection

RF stainless materials

* customized version on request

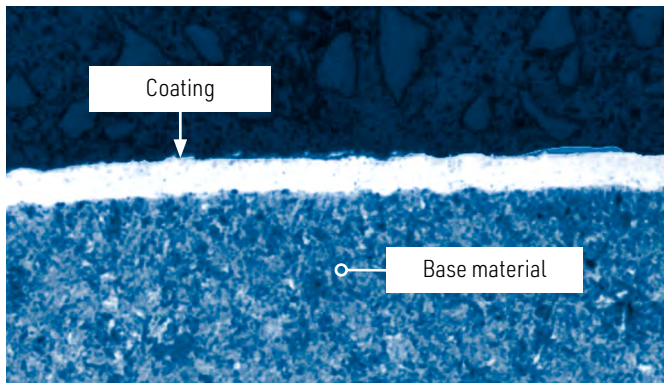

Cross-section polish of coated chain pin

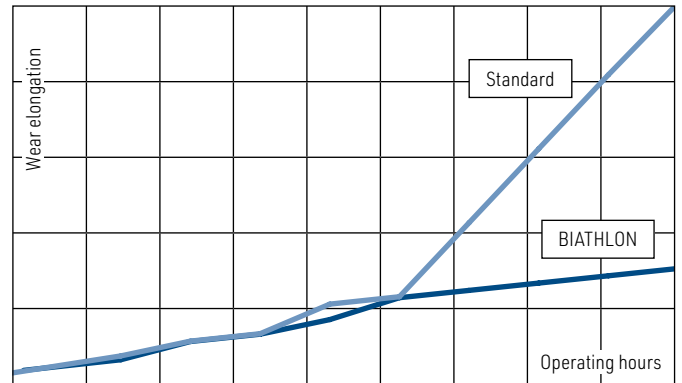

Wear diagram

BIATHLON

Highest wear resistance – also in case of minor maintenance

Range of application

The high-performance chain BIATHLON shows its advantages wherever the use of standard roller chains is not economical due to difficult maintenance conditions.

The special coating of chain pins and rollers allows for excellent dry-running operation characteristics and thus makes this chain particularly resistant against phases without sufficient relubrication. The extended wear life increases the availability of machines and equipment.

The BIATHLON chain can also be supplied in a corrosion-protected design (see page 32).

Coating

The special surface coating of the BIATHLON chain guarantees a high resistance against abrasive and adhesive wear even in case of poor lubrication. Thus fretting will be avoided to a large extent. Due to special finishing treatment procedures the surface has an optimal ductility despite its hardness.

The coating process features a reproducible layer thickness as well as an extraordinary outline constancy and an even layer thickness on the chain components.

Technical features

- Coated chain pins
- Coated rollers
- Special long-term lubricants

Benefits for application

- Particularly efficient
- Dry-running operation characteristics in case of deficient lubrication
- Corrosion-protection on request (see page 32)



Simplex chains

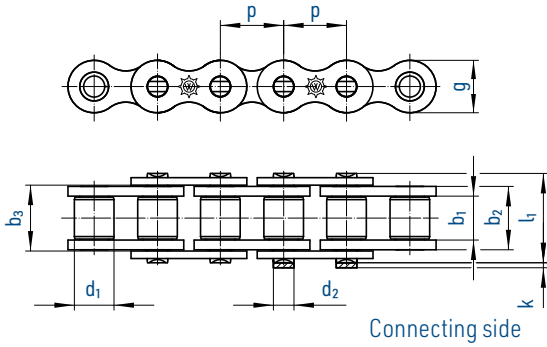

Simplex chains GL (straight plates)

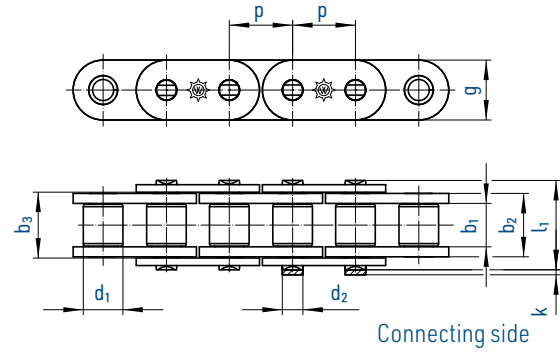

Duplex chains

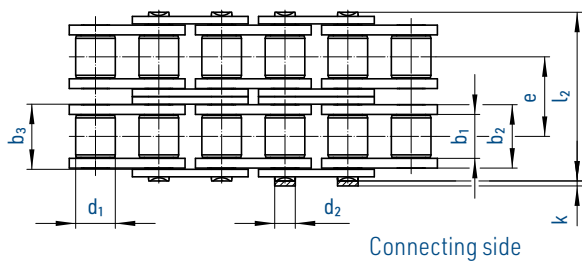

Triplex chains

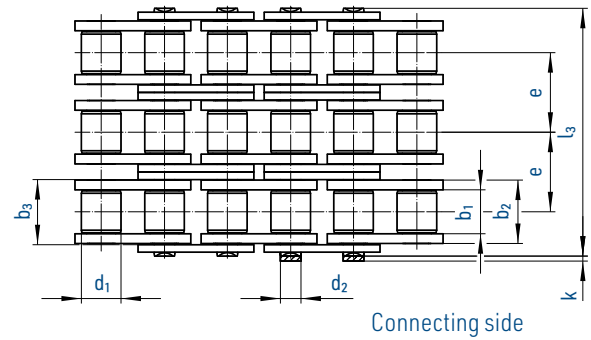

Chain according to ISO 606		Pitch		Inner width	Inner link width	Outer plate width	Roller Ø	Pin Ø	Transverse pitch	Plate height	Projection over connecting link	Width over pin	Bearing area	Breaking load	Weight	Connecting links
No.		mm	inch	b ₁ min.	b ₂ max.	b ₃ min.	d ₁ max.	d ₂ max.	e	g max.	k max.	l max.	f cm ²	F _B min. kN	q ≈ kg/m	No.
08 B-1 BI		12,700	1/2	7,75	11,30	11,43	8,51	4,45	-	11,8	3,9	17,0	0,50	18,6	0,70	11,12,15
10 B-1 BI		15,875	5/8	9,65	13,28	13,41	10,16	5,08	-	14,7	4,1	19,6	0,67	27,0	0,91	11,12,15
12 B-1 BI		19,050	3/4	11,68	15,62	15,75	12,07	5,72	-	16,1	4,6	22,7	0,89	31,0	1,18	11,12,15
16 B-1 BI		25,400	1	17,02	25,40	25,60	15,88	8,28	-	21,0	5,4	36,1	2,10	72,0	2,68	11,111,12
20 B-1 BI		31,750	1 1/4	19,56	29,00	29,20	19,05	10,19	-	26,4	6,1	43,2	2,96	105,0	3,50	111,12
24 B-1 BI		38,100	1 1/2	25,40	37,90	38,10	25,40	14,63	-	33,4	6,6	53,4	5,54	180,0	6,80	111,12
08 B-2 BI		12,700	1/2	7,75	11,30	11,43	8,51	4,45	13,92	11,8	3,9	31,0	1,01	37,0	1,36	11,12,15
10 B-2 BI		15,875	5/8	9,65	13,28	13,41	10,16	5,08	16,59	14,7	4,1	36,2	1,34	54,0	1,82	11,12,15
12 B-2 BI		19,050	3/4	11,68	15,62	15,75	12,07	5,72	19,46	16,1	4,6	42,2	1,79	63,0	2,38	11,12,15
16 B-2 BI		25,400	1	17,02	25,40	25,60	15,88	8,28	31,88	21,0	5,4	68,0	4,21	140,0	5,30	11,111,12
20 B-2 BI		31,750	1 1/4	19,56	25,40	29,20	19,05	10,19	36,45	26,4	6,1	79,7	5,91	210,0	7,30	111,12
24 B-2 BI		38,100	1 1/2	25,40	37,90	38,10	25,40	14,63	48,36	33,4	6,6	101,8	11,09	360,0	13,40	111,12
08 B-3 BI		12,700	1/2	7,75	11,30	11,43	8,51	4,45	13,92	11,8	3,9	44,9	1,51	56,0	2,01	11,12,15
10 B-3 BI		15,875	5/8	9,65	13,28	13,41	10,16	5,08	16,59	14,7	4,1	52,8	2,02	80,0	2,70	11,12,15
12 B-3 BI		19,050	3/4	11,68	15,62	15,75	12,07	5,72	19,46	16,1	4,6	61,7	2,68	94,0	3,12	11,12,15
16 B-3 BI		25,400	1	17,02	25,40	25,60	15,88	8,28	31,88	21,0	5,4	99,9	6,31	211,0	7,50	11,111,12
20 B-3 BI		31,750	1 1/4	19,56	29,00	29,20	19,05	10,19	36,45	26,4	6,1	116,1	8,87	300,0	10,60	111,12
24 B-3 BI		38,100	1 1/2	25,40	37,90	38,10	25,40	14,63	48,36	33,4	6,6	150,2	16,63	523,0	20,00	111,12

Can also be supplied with attachments and straight plates (type series GL).
Chains 16-B GLs available with plate height g = 21 mm (max.) and as type series GL with g = 24 mm (max.).

Standard sprockets can be used for these chains.

Connecting links: According to ISO (...)



No. 4 (B)
Inner link



No. 7 (A)
Outer link
(to be riveted)



No. 11 (E)
Spring clip
connecting link



No. 111 (S)
Connecting link
with cottered pin



No. 12 (L)
Single
cranked link



No. 15 (C)
Double cranked link

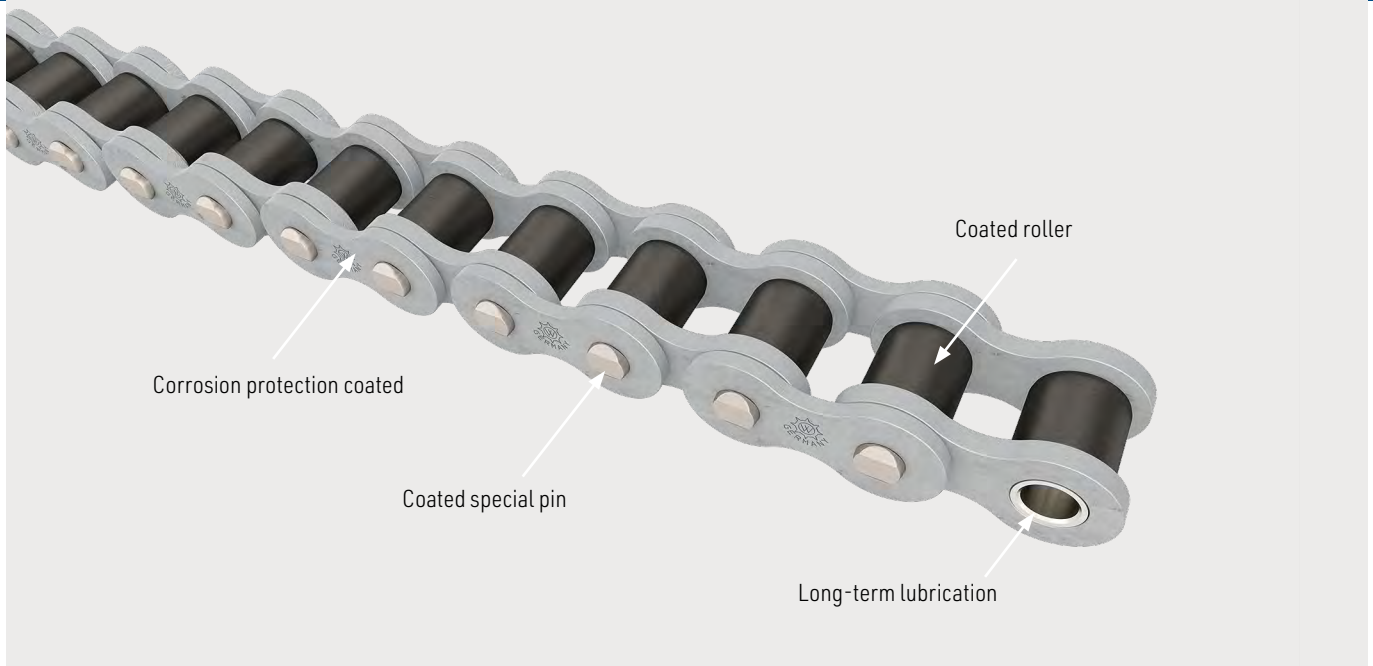

BIATHLON KS

Highest corrosion resistance in its class

Application areas

In a number of industrial sectors, e.g. in the food processing or in the packing industry, humid ambient conditions frequently impede relubrication of the chains. The annoying consequence is considerable chain wear resulting in too short change intervals and thus in unnecessarily high maintenance costs. In this case the combination of low maintenance requirements and high corrosion resistance with carbon steel chains makes double sense.

Proven quality

The KS type BIATHLON high performance chain has the highest corrosion resistance in its class. On the basis of the standard BIATHLON chain with its already excellent wear protection, environmentally-friendly corrosion protection material of the highest quality is additionally applied when manufacturing the KS type BIATHLON chain. In salt spray tests the BIATHLON KS proved to be corrosion resistant for a period of more than 1000 hours.

Under the same test conditions comparisons showed significant corrosion on competing chains after approx. 200 hours.

This long-life cycle has been achieved by combining different surface technologies that do not interact negatively with each other.

Technical features

- Highest corrosion protection thanks to zinc aluminum flake coating
- Pin with highest hardness thanks to chemical nickel plating
- Low-friction roller coating
- Special long-term lubricants

Benefits for application

- Particularly economical thanks to high corrosion and wear protection
- Dry-running operation characteristics in case of deficient lubrication
- High-tech corrosion protection
- RoHS compliance due to non-use of hexavalent chromium
- Temperature range from - 30 °C to +150 °C



Simplex chains

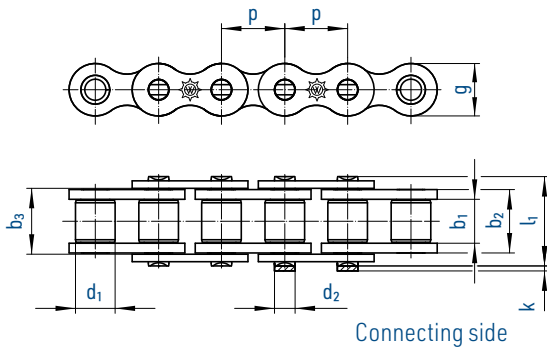

Simplex chains GL (straight plates)

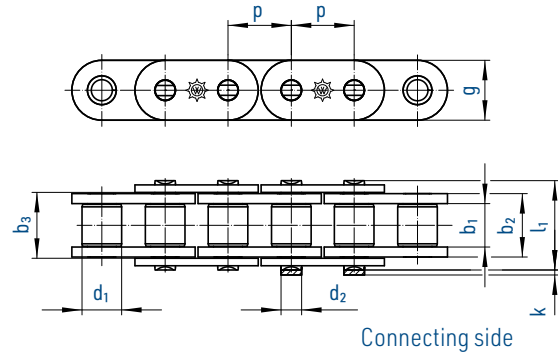

Chain according to ISO 606		Pitch		Inner width	Inner link width	Outer plate width	Roller Ø	Pin Ø	Transverse pitch	Plate height	Projection over connecting link	Width over pin	Bearing area	Breaking load	Weight	Connecting links
🔧		p		b ₁ min.	b ₂ max.	b ₃ min.	d ₁ max.	d ₂ max.	e	g max.	k max.	l max.	f	F _B min.	q ≈	No.
No.	Ind.	mm	inch	mm	mm	mm	mm	mm	mm	mm	mm	mm	cm ²	kN	kg/m	No.
08 B-1 BI KS		12,700	1/2	7,75	11,30	11,43	8,51	4,45	-	11,8	3,9	17,0	0,50	18,6	0,70	11,12,15
10 B-1 BI KS		15,875	5/8	9,65	13,28	13,41	10,16	5,08	-	14,7	4,1	19,6	0,67	27,0	0,91	11,12,15
12 B-1 BI KS		19,050	3/4	11,68	15,62	15,75	12,07	5,72	-	16,1	4,6	22,7	0,89	31,0	1,18	11,12,15
16 B-1 BI KS		25,400	1	17,02	25,40	25,60	15,88	8,28	-	21,0	5,4	36,1	2,10	72,0	2,68	11,111,12
20 B-1 BI KS		31,750	1 1/4	19,56	29,00	29,20	19,05	10,19	-	26,4	6,1	43,2	2,96	105,0	3,50	111,12
24 B-1 BI KS		38,100	1 1/2	25,40	37,90	38,20	25,40	14,63	-	33,4	6,6	53,4	5,54	180,0	6,80	111,12
28 B-1 BI KS		44,450	1 3/4	30,99	46,60	46,70	27,94	15,90	-	37,0	7,4	65,1	7,39	230,0	8,50	111,12
32 B-1 BI KS		50,800	2	30,99	45,60	45,70	29,21	17,81	-	42,3	7,9	67,4	8,10	276,0	10,50	111,12

Other chain sizes available on request. Can also be supplied with attachments and straight plates (type series GL). Chains 16-B GLS available with plate height g = 21 mm (max.) and as type series GL with g = 24 mm (max.)

For details on orders and enquiries see page 148. Standard sprockets as of page 103. Information on the selection of chain sizes and drives as of page 136.

Standard sprockets can be used for these chains.

Connecting links: According to ISO (...)



No. 4 (B)
Inner link



No. 7 (A)
Outer link
(to be riveted)



No. 11 (E)
Spring clip
connecting link



No. 111 (S)
Connecting link
with cottered pin



No. 12 (L)
Single
cranked link



No. 15 (C)
Double cranked link

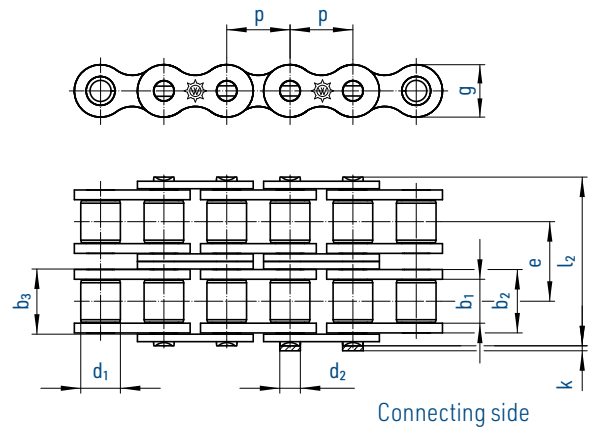

Chain according to ISO 606		Pitch		Inner width	Inner link width	Outer plate width	Roller Ø	Pin Ø	Transverse pitch	Plate height	Projection over connecting link	Width over pin	Bearing area	Breaking load	Weight	Connecting links
⚙️		p		b ₁ min.	b ₂ max.	b ₃ min.	d ₁ max.	d ₂ max.	e	g max.	k max.	l max.	f	F _B min.	q ≈	No.
No.	Ind.	mm	inch	mm	mm	mm	mm	mm	mm	mm	mm	mm	cm ²	kN	kg/m	No.
08 B-2 BI KS		12,700	1/2	7,75	11,30	11,43	8,51	4,45	13,92	11,8	3,9	31,0	1,01	37,0	1,36	11,12,15
10 B-2 BI KS		15,875	5/8	9,65	13,28	13,41	10,16	5,08	16,59	14,7	4,1	36,2	1,34	54,0	1,82	11,12,15
12 B-2 BI KS		19,050	3/4	11,68	15,62	15,75	12,07	5,72	19,46	16,1	4,6	42,2	1,79	63,0	2,38	11,12,15
16 B-2 BI KS		25,400	1	17,02	25,40	25,60	15,88	8,28	31,88	21,0	5,4	68,0	4,21	140,0	5,30	11,111,12
20 B-2 BI KS		31,750	1 1/4	19,56	25,40	29,20	19,05	10,19	36,45	26,4	6,1	79,7	5,91	210,0	7,30	111,12
24 B-2 BI KS		38,100	1 1/2	25,40	37,90	38,10	25,40	14,63	48,36	33,4	6,6	101,8	11,09	360,0	13,40	111,12
28 B-2 BI KS		44,450	1 3/4	30,99	46,60	46,70	27,94	15,90	59,56	37,0	7,4	124,7	14,79	443,0	16,60	111,12
32 B-2 BI KS		50,800	2	30,99	45,60	45,70	29,21	17,81	58,55	42,3	7,9	126,0	16,21	530,0	21,00	111,12

Other chain sizes available on request. Can also be supplied with attachments and straight plates (type series GL). Chains 16-B GLS available with plate height g = 21 mm (max.) and as type series GL with g = 24 mm (max.).

For details on orders and enquiries see page 148. Sprockets on request. Information on the selection of chain sizes and drives as of page 136.

Standard sprockets can be used for these chains.

Connecting links: According to ISO (...)



No. 4 (B)
Inner link



No. 7 (A)
Outer link
(to be riveted)



No. 11 (E)
Spring clip
connecting link



No. 111 (S)
Connecting link
with cottered pin



No. 12 (L)
Single
cranked link



No. 15 (C)
Double cranked link

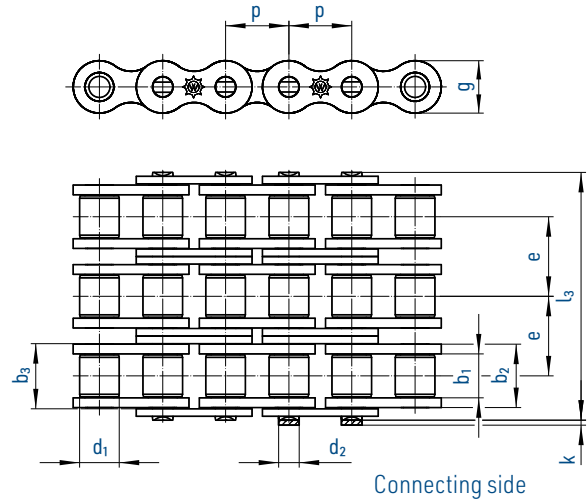
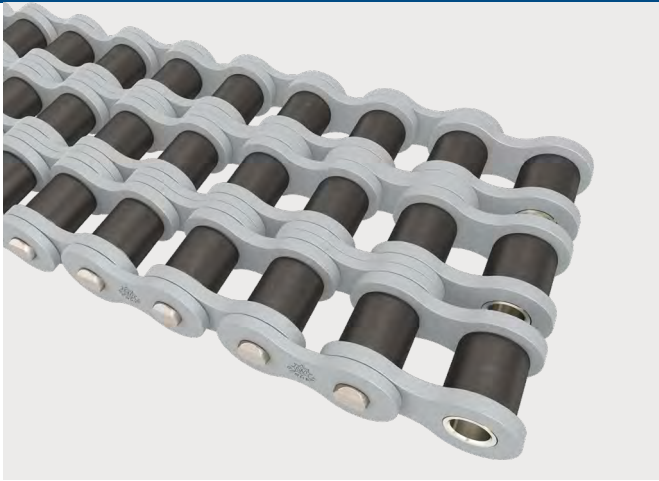

Chain according to ISO 606		Pitch		Inner width	Inner link width	Outer plate width	Roller Ø	Pin Ø	Transverse pitch	Plate height	Projection over connecting link	Width over pin	Bearing area	Breaking load	Weight	Connecting links
⚙️		p		b ₁ min.	b ₂ max.	b ₃ min.	d ₁ max.	d ₂ max.	e	g max.	k max.	l max.	f cm ²	F _B min. kN	q ≈ kg/m	No.
No.	Ind.	mm	inch	mm	mm	mm	mm	mm	mm	mm	mm	mm	cm ²	kN	kg/m	No.
08 B-3 BI KS		12,700	1/2	7,75	11,30	11,43	8,51	4,45	13,92	11,8	3,9	44,9	1,51	56,0	2,01	11,12,15
10 B-3 BI KS		15,875	5/8	9,65	13,28	13,41	10,16	5,08	16,59	14,7	4,1	52,8	2,02	80,0	2,70	11,12,15
12 B-3 BI KS		19,050	3/4	11,68	15,62	15,75	12,07	5,72	19,46	16,1	4,6	61,7	2,68	94,0	3,12	11,12,15
16 B-3 BI KS		25,400	1	17,02	25,40	25,60	15,88	8,28	31,88	21,0	5,4	99,9	6,31	211,0	7,50	11,111,12
20 B-3 BI KS		31,750	1 1/4	19,56	29,00	29,20	19,05	10,19	36,45	26,4	6,1	116,1	8,87	300,0	10,60	111,12
24 B-3 BI KS		38,100	1 1/2	25,40	37,90	38,10	25,40	14,63	48,36	33,4	6,6	150,2	16,63	523,0	20,00	111,12
28 B-3 BI KS		44,450	1 3/4	30,99	46,60	46,70	27,94	15,90	59,56	37,0	7,4	184,3	22,18	660,0	25,00	111,12
32 B-3 BI KS		50,800	2	30,99	45,60	45,70	29,21	17,81	58,55	42,3	7,9	184,5	24,31	800,0	32,00	111,12

Other chain sizes available on request. Can also be supplied with attachments and straight plates (type series GL). Chains 16-B GLS available with plate height g = 21 mm (max.) and as type series GL with g = 24 mm (max.)

For details on orders and enquiries see page 148. Sprockets on request. Information on the selection of chain sizes and drives as of page 136.

Standard sprockets can be used for these chains.

Connecting links: According to ISO (...)

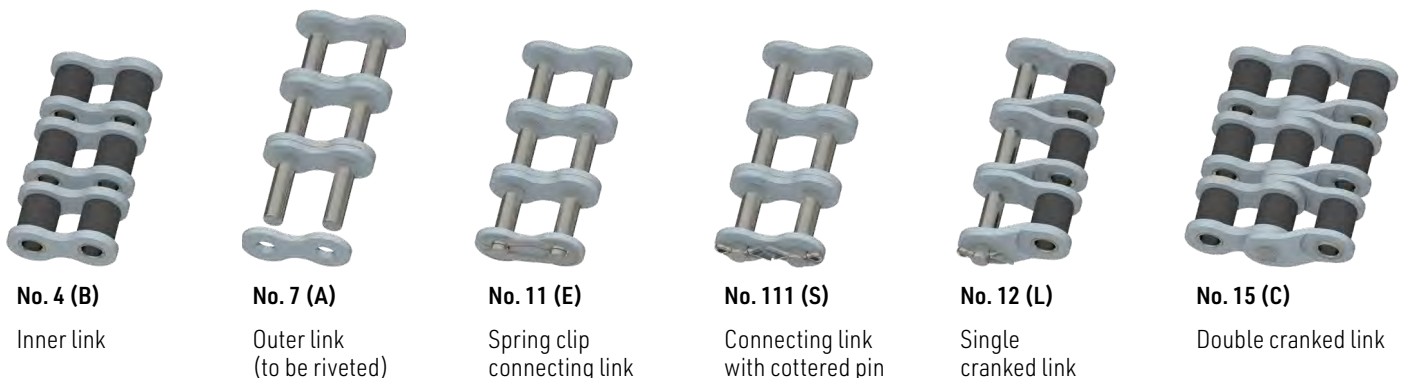



TRIATHLON HT

Maintenance-free and high load bearing up to 200 °C

The TRIATHLON HT high-performance chain has a high load capacity for temperatures up to 200°C, even without additional lubricants, and is extremely wear-resistant.

Whether with minimal surface lubrication to protect the sprockets or completely free of lubrication for highly sensitive applications, the TRIATHLON HT sets new standards with perfectly coordinated materials, coated pins, special coated rollers and also through its innovative high-tech polymer bushings in numerous application areas.

Designed for difficult applications

In many production processes, the combination of high temperatures and sensitive components present specific requirements for the chains.

In the automotive industry, hoisting and conveyor chains thus reduce scrap in the coating process by avoiding unwanted paint wetting with lubricant residues, in contrast to conventionally lubricated chains. In the electrical industry, chains have to be complete dry without lubrication to avoid chemical reactions e.g. in casting resins.

Proven in practice

The durability of the TRIATHLON HT is achieved through unique material combinations with special coated pins and polymer bearings. Many renowned companies have recognised the benefits of the TRIATHLON HT and are already demonstrating the success of our high-performance chains under high loads and temperatures, which require uncompromised durability and wear resistance.

Technical features

- High-tech polymer bearings with maximum temperature resistance
- Chemically nickel-plated pins and carrier bushes with the highest hardness
- Low-friction roller coating

Benefits for application

- Highly resilient, low friction chain joints
- No relubrication required
- Lubricant-free for chain speeds up to 2.5m/s
- Temperature range from - 30 °C to +200 °C

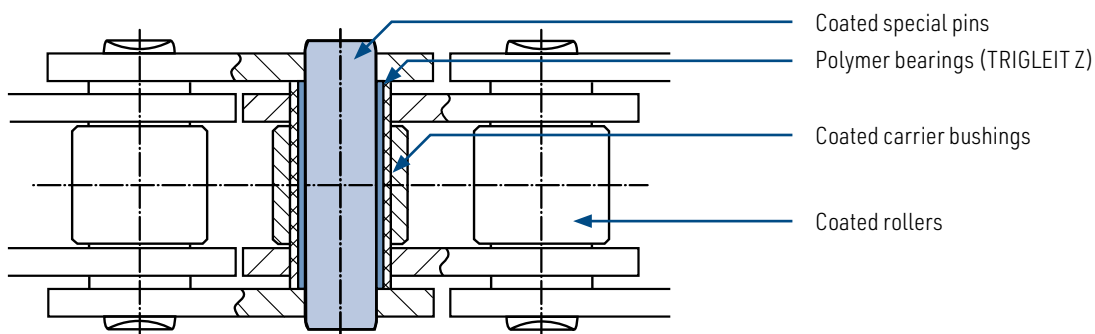



Simplex chains

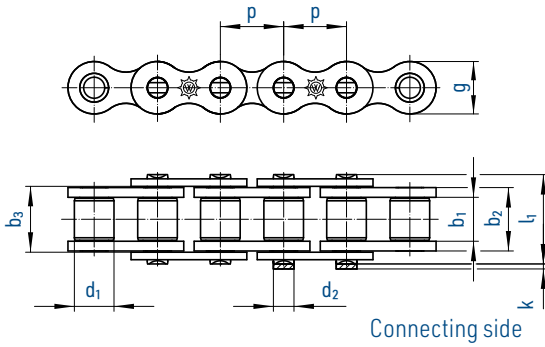

Simplex chains GL (straight plates)

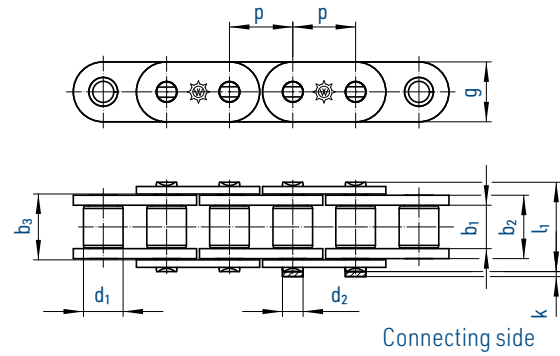

Duplex chains

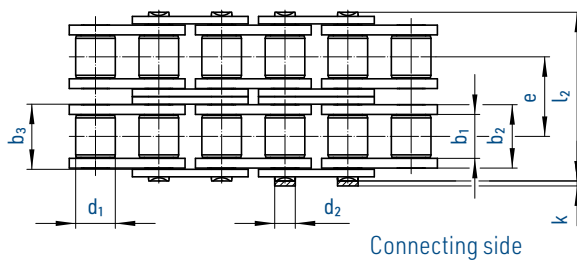

Triplex chains

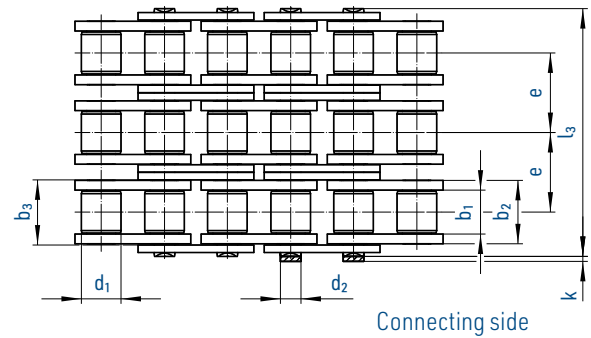

Chain according to ISO 606		Pitch		Inner width	Inner link width	Outer plate width	Roller Ø	Pin Ø	Transverse pitch	Plate height	Projection over connecting link	Width over pin	Bearing area	Breaking load	Weight	Connecting links
No.		mm	inch	b ₁ min.	b ₂ max.	b ₃ min.	d ₁ max.	d ₂ max.	e	g max.	k max.	l max.	f cm ²	F _B min. kN	q ≈ kg/m	No.
08 B-1 TR HT		12,700	1/2	7,75	11,30	11,43	8,51	4,45	-	11,8	3,9	17,0	0,50	18,6	0,70	11,12,15
10 B-1 TR HT		15,875	5/8	9,65	13,28	13,41	10,16	5,08	-	14,7	4,1	19,6	0,67	27,0	0,91	11,12,15
12 B-1 TR HT		19,050	3/4	11,68	15,62	15,75	12,07	5,72	-	16,1	4,6	22,7	0,89	31,0	1,18	11,12,15
16 B-1 TR HT		25,400	1	17,02	25,40	25,60	15,88	8,28	-	21,0	5,4	36,1	2,10	72,0	2,68	11,111,12
20 B-1 TR HT		31,750	1 1/4	19,56	29,00	29,20	19,05	10,19	-	26,4	6,1	43,2	2,96	105,0	3,50	111,12
24 B-1 TR HT		38,100	1 1/2	25,40	37,90	38,10	25,40	14,63	-	33,4	6,6	53,4	5,54	180,0	6,80	111,12
08 B-2 TR HT		12,700	1/2	7,75	11,30	11,43	8,51	4,45	13,92	11,8	3,9	31,0	1,01	37,0	1,36	11,12,15
10 B-2 TR HT		15,875	5/8	9,65	13,28	13,41	10,16	5,08	16,59	14,7	4,1	36,2	1,34	54,0	1,82	11,12,15
12 B-2 TR HT		19,050	3/4	11,68	15,62	15,75	12,07	5,72	19,46	16,1	4,6	42,2	1,79	63,0	2,38	11,12,15
16 B-2 TR HT		25,400	1	17,02	25,40	25,60	15,88	8,28	31,88	21,0	5,4	68,0	4,21	140,0	5,30	11,111,12
20 B-2 TR HT		31,750	1 1/4	19,56	25,40	29,20	19,05	10,19	36,45	26,4	6,1	79,7	5,91	210,0	7,30	111,12
24 B-2 TR HT		38,100	1 1/2	25,40	37,90	38,10	25,40	14,63	48,36	33,4	6,6	101,8	11,09	360,0	13,40	111,12
08 B-3 TR HT		12,700	1/2	7,75	11,30	11,43	8,51	4,45	13,92	11,8	3,9	44,9	1,51	56,0	2,01	11,12,15
10 B-3 TR HT		15,875	5/8	9,65	13,28	13,41	10,16	5,08	16,59	14,7	4,1	52,8	2,02	80,0	2,70	11,12,15
12 B-3 TR HT		19,050	3/4	11,68	15,62	15,75	12,07	5,72	19,46	16,1	4,6	61,7	2,68	94,0	3,12	11,12,15
16 B-3 TR HT		25,400	1	17,02	25,40	25,60	15,88	8,28	31,88	21,0	5,4	99,9	6,31	211,0	7,50	11,111,12
20 B-3 TR HT		31,750	1 1/4	19,56	29,00	29,20	19,05	10,19	36,45	26,4	6,1	116,1	8,87	300,0	10,60	111,12
24 B-3 TR HT		38,100	1 1/2	25,40	37,90	38,10	25,40	14,63	48,36	33,4	6,6	150,2	16,63	523,0	20,00	111,12

Other chain sizes available on request. Can also be supplied with attachments and straight plates (type series GL).
Chains 16-B GLS available with plate height g = 21 mm (max.) and as type series GL with g = 24 mm (max.)

Standard sprockets can be used for these chains.

Connecting links: According to ISO (...)



No. 4 (B)

Inner link



No. 7 (A)

Outer link
(to be riveted)



No. 11 (E)

Spring clip
connecting link



No. 111 (S)

Connecting link
with cottered pin



No. 12 (L)

Single
cranked link



No. 15 (C)

Double cranked link



TRIATHLON KS

Corrosion resistant and lubrication-free for highly sensitive production processes

With TRIATHLON KS, we expand our leadership role for maintenance-free chains that do not require lubrication. Especially in sensitive production processes, e.g. in the food, cosmetics and packaging industry, it proves to be a real all-rounder due to its high load bearing carbon steels, environmentally friendly corrosion protection and our tried and proved TRIGLEIT FDA polymer bushings.

Application areas

The TRIATHLON KS chain is ideally suited for application in large systems, intermittent operation and humid ambient conditions. Thanks to its high durability and wear resistance without the need for relubrication, its application is particularly economic in these areas.

Corrosion protection at its best

Just like BIATHLON KS, which has been providing excellent service in many years of practical use, the TRIATHLON KS features environmentally friendly corrosion protection which has proved to be highly resistant for a period of more than 1,000 hours in salt spray tests. Whether with minimal H1 surface lubrication to protect the sprockets or completely free of lubrication, the TRIATHLON KS sets new standards in terms of loading capacity, corrosion resistance, durability and wear resistance with perfectly coordinated materials, functional layers and innovative TRIGLEIT FDA polymer bushings.

Technical features

- Coated bushings with TRIGLEIT FDA inserts
- Coated pins and plates
- Rolls made of corrosion resistant steel with maximum ductility

Benefits for application

- High-tech corrosion protection
- RoHS compliance due to non-use of hexavalent chromium
- Highly resilient, low friction chain joints
- No relubrication required
- Lubricant-free for chain speeds up to 2.5 m/s
- Temperatures from -30°C to +150°C (up to +200°C on request)

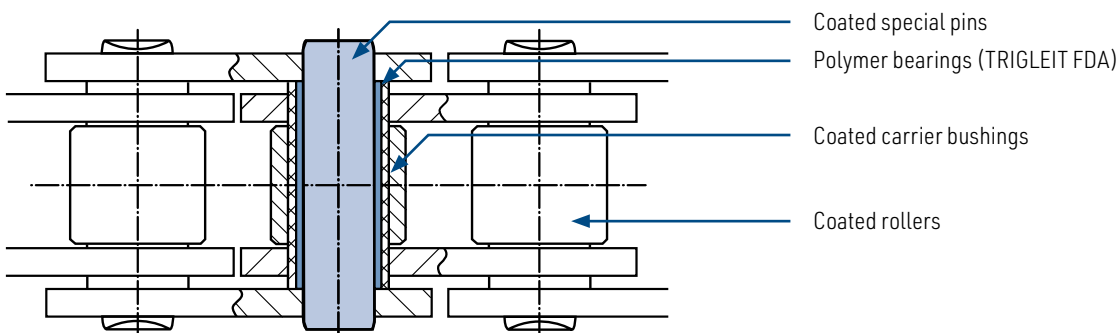



Simplex chains

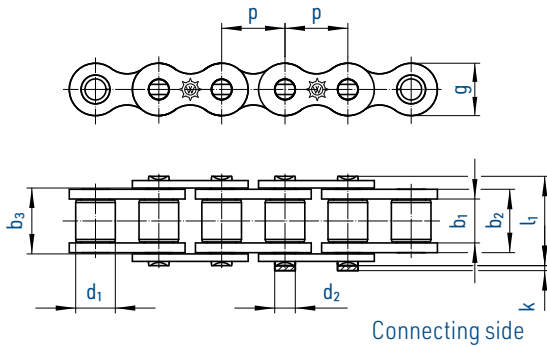

Simplex chains GL (straight plates)

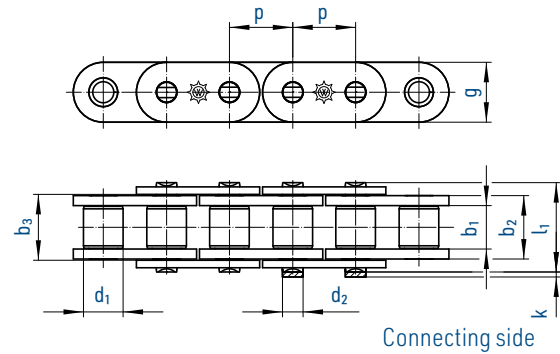

Duplex chains

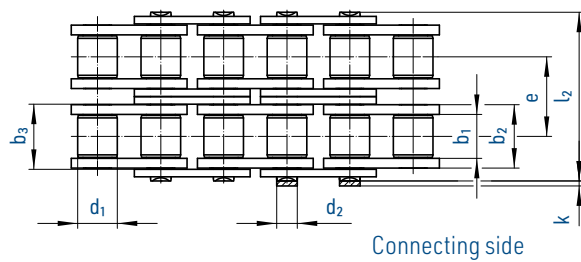

Triplex chains

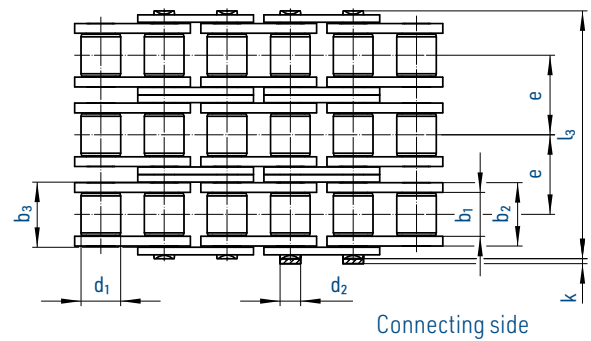

Chain according to ISO 606		Pitch		Inner width	Inner link width	Outer plate width	Roller Ø	Pin Ø	Transverse pitch	Plate height	Projection over connecting link	Width over pin	Bearing area	Breaking load	Weight	Connecting links
No.		mm	inch	b ₁ min.	b ₂ max.	b ₃ min.	d ₁ max.	d ₂ max.	e	g max.	k max.	l max.	f cm ²	F _B min. kN	q ≈ kg/m	No.
08 B-1 TR KS		12,700	1/2	7,75	11,30	11,43	8,51	4,45	-	11,8	3,9	17,0	0,50	18,6	0,70	11,12,15
10 B-1 TR KS		15,875	5/8	9,65	13,28	13,41	10,16	5,08	-	14,7	4,1	19,6	0,67	27,0	0,91	11,12,15
12 B-1 TR KS		19,050	3/4	11,68	15,62	15,75	12,07	5,72	-	16,1	4,6	22,7	0,89	31,0	1,18	11,12,15
16 B-1 TR KS		25,400	1	17,02	25,40	25,60	15,88	8,28	-	21,0	5,4	36,1	2,10	72,0	2,68	11,111,12
20 B-1 TR KS		31,750	1 1/4	19,56	29,00	29,20	19,05	10,19	-	26,4	6,1	43,2	2,96	105,0	3,50	111,12
24 B-1 TR KS	*	38,100	1 1/2	25,40	37,90	38,10	25,40	14,63	-	33,4	6,6	53,4	5,54	180,0	6,80	111,12
08 B-2 TR KS		12,700	1/2	7,75	11,30	11,43	8,51	4,45	13,92	11,8	3,9	31,0	1,01	37,0	1,36	11,12,15
10 B-2 TR KS		15,875	5/8	9,65	13,28	13,41	10,16	5,08	16,59	14,7	4,1	36,2	1,34	54,0	1,82	11,12,15
12 B-2 TR KS		19,050	3/4	11,68	15,62	15,75	12,07	5,72	19,46	16,1	4,6	42,2	1,79	63,0	2,38	11,12,15
16 B-2 TR KS		25,400	1	17,02	25,40	25,60	15,88	8,28	31,88	21,0	5,4	68,0	4,21	140,0	5,30	11,111,12
20 B-2 TR KS		31,750	1 1/4	19,56	25,40	29,20	19,05	10,19	36,45	26,4	6,1	79,7	5,91	210,0	7,30	111,12
24 B-2 TR KS	*	38,100	1 1/2	25,40	37,90	38,10	25,40	14,63	48,36	33,4	6,6	101,8	11,09	360,0	13,40	111,12
08 B-3 TR KS		12,700	1/2	7,75	11,30	11,43	8,51	4,45	13,92	11,8	3,9	44,9	1,51	56,0	2,01	11,12,15
10 B-3 TR KS		15,875	5/8	9,65	13,28	13,41	10,16	5,08	16,59	14,7	4,1	52,8	2,02	80,0	2,70	11,12,15
12 B-3 TR KS		19,050	3/4	11,68	15,62	15,75	12,07	5,72	19,46	16,1	4,6	61,7	2,68	94,0	3,12	11,12,15
16 B-3 TR KS		25,400	1	17,02	25,40	25,60	15,88	8,28	31,88	21,0	5,4	99,9	6,31	211,0	7,50	11,111,12
20 B-3 TR KS		31,750	1 1/4	19,56	29,00	29,20	19,05	10,19	36,45	26,4	6,1	116,1	8,87	300,0	10,60	111,12
24 B-3 TR KS	*	38,100	1 1/2	25,40	37,90	38,10	25,40	14,63	48,36	33,4	6,6	150,2	16,63	523,0	20,00	111,12

* chemically nickel-plated rollers

Other chain sizes available on request. Can also be supplied with attachments and straight plates (type series GL).
Chains 16-B GLS available with plate height g = 21 mm (max.) and as type series GL with g = 24 mm (max.)

Standard sprockets can be used for these chains.

Connecting links: According to ISO (...)



No. 4 (B)
Inner link



No. 7 (A)
Outer link
(to be riveted)



No. 11 (E)
Spring clip
connecting link



No. 111 (S)
Connecting link
with cottered pin



No. 12 (L)
Single
cranked link



No. 15 (C)
Double cranked link



MARATHON

Long distance chain that needs no relubrication

Apart from availability, operational safety and reliability, the fact that components are maintenance-free is getting more and more important in machine and plant construction. The use of MARATHON chains always makes sense where relubrication of roller chains is either not possible or not desired, but where, nevertheless, a long life cycle is required.

Technical features

- Up to 35 times longer wear life in comparison with other standard roller chains without lubrication
- Up to 5 times longer wear life than other maintenance-free chains
- No relubrication required
- Clean application with no soiling of machinery and transported goods
- Joint bushings made with a new type of sintered metal with high strength treated with a special lubricant
- High-performance bearing joints
- Bushings longer than the width of the chain link with sliding contact to the outer plate
- The pins forming the joints with these bushings are made of alloyed hardened steel and are treated with a special coating. The resulting high-wearing coat guarantees an excellent sliding performance.
- Same tensile strength as with WIPPERMANN standard chains
- All MARATHON chains fit standard sprockets

Application areas

- Temperatures from 0°C to +100°C
- With special lubrication from -30°C to +250°C (after consultation)
- Speeds of up to $v = 150$ m/min.
- Electrical industry
- Production of printed circuit boards (PCBs)
- Television industry
- Packing industry
- Paper processing
- Printing industry
- Bookbinding industry
- Textile industry
- Automotive industry
- All systems where relubrication is either not wanted, problematic or not possible at all.

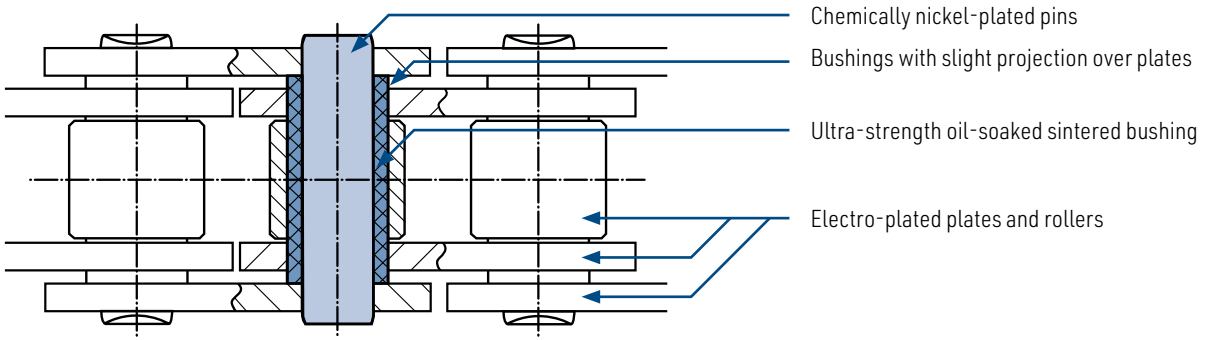

Force projection diagram

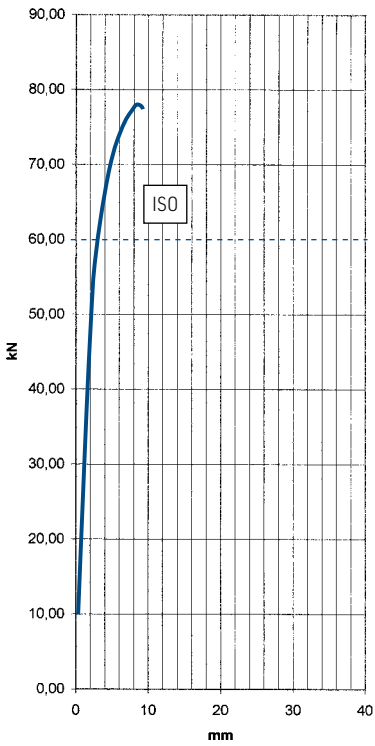

Type of test: Tensile test
Object: 548 MARATHON chain
Test length: 5 links
Breaking load: 78,000 N
Breaking point: Pins

Results of long-term wear tests

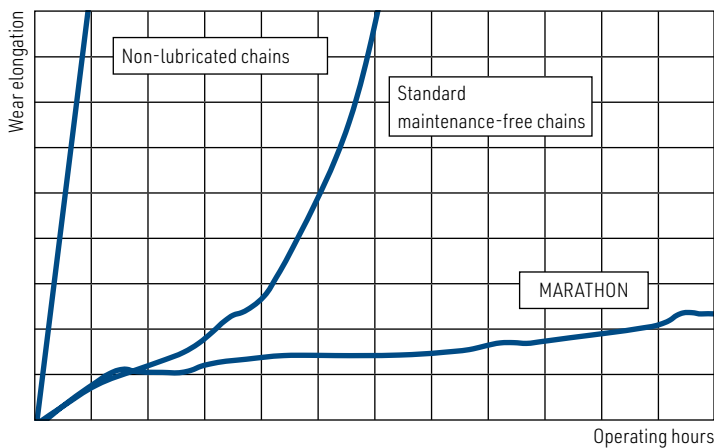



Simplex chains

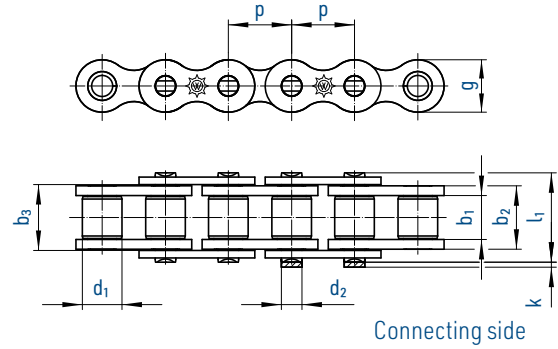

Duplex chains

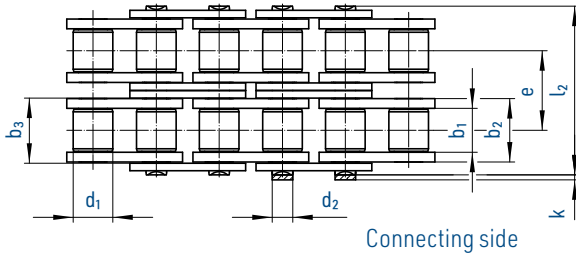

Triplex chains

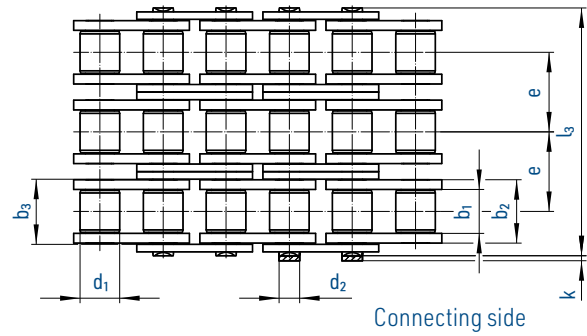

Chain according to ISO 606		Pitch		Inner width	Inner link width	Outer plate width	Roller Ø	Pin Ø	Transverse pitch	Plate height	Projection over connecting link	Width over pin	Bearing area	Breaking load	Weight	Connecting links
⚙️		p		b ₁ min.	b ₂ max.	b ₃ min.	d ₁ max.	d ₂ max.	e	g max.	k max.	l max.	f	F _B min.	q ≈	No.
No.	Ind.	mm	inch	mm	mm	mm	mm	mm	mm	mm	mm	mm	cm ²	kN	kg/m	No.
06 B-1 MA	¹	9,525	3/8	5,72	8,53	8,66	6,35	3,28	-	8,2	3,3	13,5	0,28	9,6	0,41	11,12,15
08 B-1 MA		12,700	1/2	7,75	11,30	11,43	8,51	4,45	-	11,8	3,9	17,0	0,50	18,6	0,70	11,12,15
10 B-1 MA		15,875	5/8	9,65	13,28	13,41	10,16	5,08	-	14,7	4,1	19,6	0,67	27,0	0,91	11,12,15
12 B-1 MA		19,050	3/4	11,68	15,62	15,75	12,07	5,72	-	16,1	4,6	22,7	0,89	31,0	1,18	11,12,15
16 B-1 MA		25,400	1	17,02	25,40	25,60	15,88	8,28	-	21,0	5,4	36,1	2,10	72,0	2,68	11,111,12
552 MA		30,000	-	17,02	25,40	25,60	15,88	8,28	-	21,0	5,4	36,1	2,10	72,0	2,50	11,111,12
20 B-1 MA		31,750	1 1/4	19,56	29,00	29,20	19,05	10,19	-	26,4	6,1	43,2	2,96	105,0	3,50	11,111,12
24 B-1 MA		38,100	1 1/2	25,40	37,90	38,10	25,40	14,63	-	33,4	6,6	53,4	5,54	180,0	6,80	111,12
06 B-2 MA	¹	9,525	3/8	5,72	8,53	8,66	6,35	3,28	10,24	8,2	3,3	23,8	0,56	17,4	0,86	11,12,15
08 B-2 MA		12,700	1/2	7,75	11,30	11,43	8,51	4,45	13,92	11,8	3,9	31,0	1,01	37,0	1,36	11,12,15
10 B-2 MA		15,875	5/8	9,65	13,28	13,41	10,16	5,08	16,59	14,7	4,1	36,2	1,34	54,0	1,82	11,12,15
12 B-2 MA		19,050	3/4	11,68	15,62	15,75	12,07	5,72	19,46	16,1	4,6	42,2	1,79	63,0	2,38	11,12,15
16 B-2 MA		25,400	1	17,02	25,40	25,60	15,88	8,28	31,88	21,0	5,4	68,0	4,21	140,0	5,30	11,111,12
20 B-2 MA		31,750	1 1/4	19,56	25,40	29,20	19,05	10,19	36,45	26,4	6,1	79,7	5,91	210,0	7,30	111,12
24 B-2 MA		38,100	1 1/2	25,40	37,90	38,10	25,40	14,63	48,36	33,4	6,6	101,8	11,09	360,0	13,40	111,12
06 B-3 MA	¹	9,525	3/8	5,72	8,53	8,66	6,35	3,28	10,24	8,2	3,3	34,0	0,81	24,9	1,30	11,12,15
08 B-3 MA		12,700	1/2	7,75	11,30	11,43	8,51	4,45	13,92	11,8	3,9	44,9	1,51	56,0	2,01	11,12,15
10 B-3 MA		15,875	5/8	9,65	13,28	13,41	10,16	5,08	16,59	14,7	4,1	52,8	2,02	80,0	2,70	11,12,15
12 B-3 MA		19,050	3/4	11,68	15,62	15,75	12,07	5,72	19,46	16,1	4,6	61,7	2,68	94,0	3,12	11,12,15
16 B-3 MA		25,400	1	17,02	25,40	25,60	15,88	8,28	31,88	21,0	5,4	99,9	6,31	211,0	7,50	11,111,12
20 B-3 MA		31,750	1 1/4	19,56	29,00	29,20	19,05	10,19	36,45	26,4	6,1	116,1	8,87	300,0	10,60	111,12
24 B-3 MA		38,100	1 1/2	25,40	37,90	38,10	25,40	14,63	48,36	33,4	6,6	150,2	16,63	523,0	20,00	111,12

¹ with straight side plates

Standard sprockets can be used for these chains.

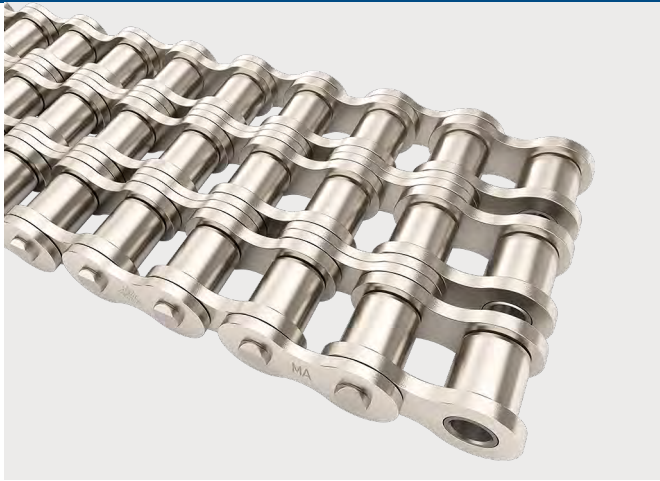

Simplex chains

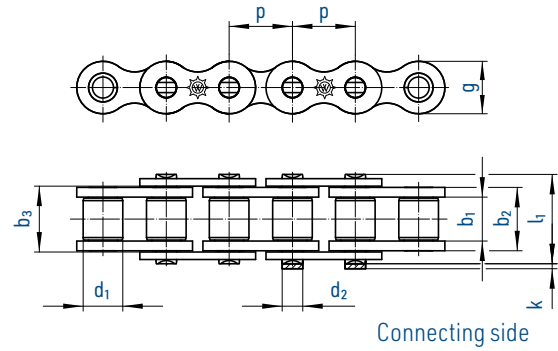

Duplex chains

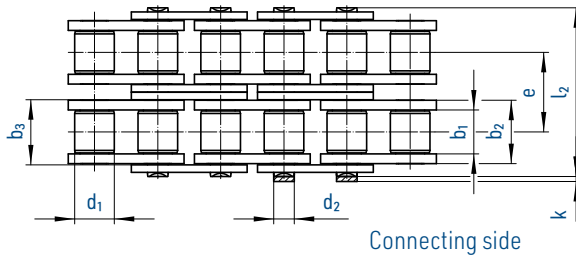

Triplex chains

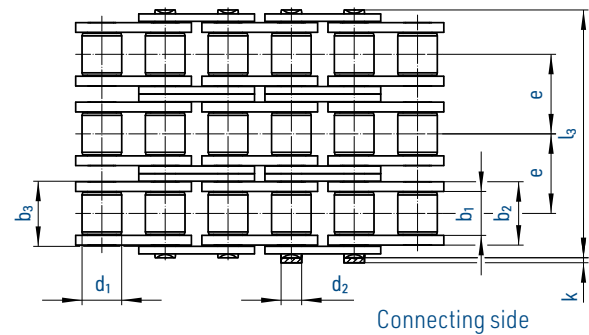

Chain according to ISO 606		Pitch		Inner width	Inner link width	Outer plate width	Roller \varnothing	Pin \varnothing	Transverse pitch	Plate height	Projection over connecting link	Width over pin	Bearing area	Breaking load F_B min.	Weight q \approx	Connecting links
No.		mm	inch	b_1 min.	b_2 max.	b_3 min.	d_1 max.	d_2 max.	e	g max.	k max.	l max.	f	F_B min.	q \approx	No.
08 A-1 MA		12,700	1/2	7,85	11,17	11,23	7,92	3,98	-	12,0	3,9	17,8	0,44	16,5	0,60	11,12,15
10 A-1 MA		15,875	5/8	9,40	13,84	13,90	10,16	5,09	-	15,1	4,1	21,8	0,70	30,0	1,01	11,12,15
12 A-1 MA		19,050	3/4	12,57	17,75	17,81	11,91	5,96	-	18,1	4,6	26,9	1,05	40,0	1,58	11,111,12,15
16 A-1 MA		25,400	1	15,75	22,60	22,66	15,88	7,94	-	24,1	5,4	33,5	1,78	69,0	2,36	11,111,12,15
20 A-1 MA		31,750	1 1/4	18,90	27,45	27,51	19,05	9,54	-	30,2	6,1	41,1	2,61	92,5	3,80	111,12
08 A-2 MA		12,700	1/2	7,85	11,17	11,23	7,92	3,98	14,38	12,0	3,9	32,3	0,88	29,7	1,20	11,12,15
10 A-2 MA		15,875	5/8	9,40	13,84	13,90	10,16	5,09	18,11	15,1	4,1	39,9	1,40	62,0	1,78	11,12,15
12 A-2 MA		19,050	3/4	12,57	17,75	17,81	11,91	5,96	22,78	18,1	4,6	49,8	2,10	76,0	3,15	11,111,12,15
16 A-2 MA		25,400	1	15,75	22,60	23,66	15,88	7,94	29,29	24,1	5,4	62,7	3,56	135,0	4,90	11,111,12,15
20 A-2 MA		31,750	1 1/4	18,90	27,45	27,51	19,05	9,54	35,76	30,2	6,1	77,0	5,22	205,0	7,60	111,12
08 A-3 MA		12,700	1/2	7,85	11,17	11,23	7,92	3,98	14,38	12,0	3,9	46,7	1,32	41,2	1,80	11,12,15
10 A-3 MA		15,875	5/8	9,40	13,84	13,90	10,16	5,09	18,11	15,1	4,1	57,9	2,10	88,0	3,02	11,12,15
12 A-3 MA		19,050	3/4	12,57	17,75	17,81	11,91	5,96	22,78	18,1	4,6	72,6	3,15	105,0	4,70	11,111,12,15
16 A-3 MA		25,400	1	15,75	22,60	22,66	15,88	7,94	29,29	24,1	5,4	91,9	5,35	193,0	7,50	11,111,12,15
20 A-3 MA		31,750	1 1/4	18,90	27,45	27,51	19,05	9,54	35,76	30,2	6,1	113,0	7,83	305,0	11,20	111,12

Sprockets on request.



Simplex chains

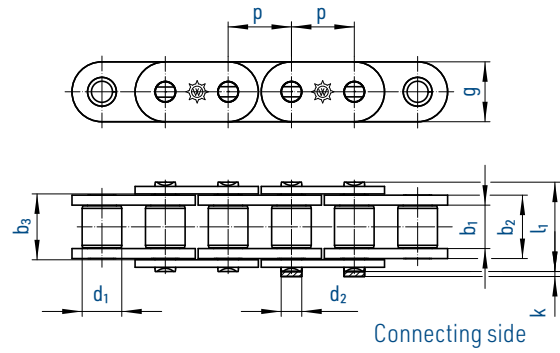

Duplex chains

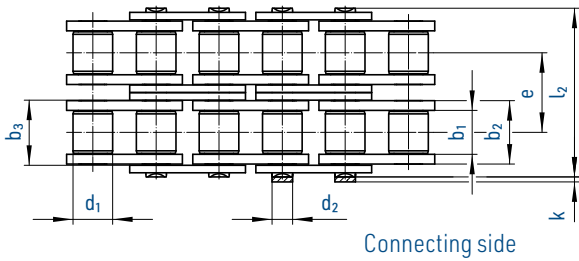

Triplex chains

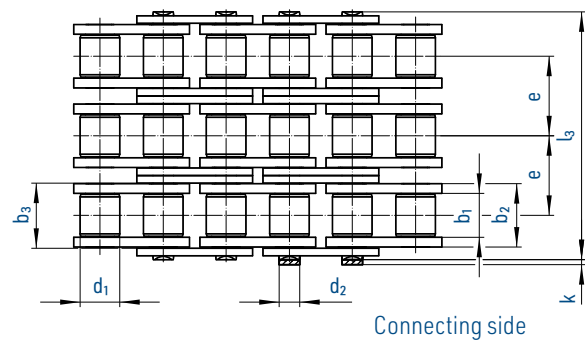

Chain according to ISO 606		Pitch		Inner width	Inner link width	Outer plate width	Roller Ø	Pin Ø	Transverse pitch	Plate height	Projection over connecting link	Width over pin	Bearing area	Breaking load	Weight	Connecting links
No.		Ind.	p	b ₁ min.	b ₂ max.	b ₃ min.	d ₁ max.	d ₂ max.	e	g max.	k max.	l max.	f	F _B min.	q ≈	No.
455 GL MA			9,525 3/8	5,72	8,53	8,66	6,35	3,28	-	8,2	3,3	13,5	0,28	9,6	0,41	4,7,11,12,15
462 GL MA			12,700 1/2	7,75	11,30	11,43	8,51	4,45	-	11,5	3,9	17,0	0,50	18,6	0,78	4,7,11,12
501 GL MA			15,875 5/8	9,65	13,28	13,41	10,16	5,08	-	14,2	4,1	19,6	0,67	27,0	1,03	4,7,11
513 GL MA			19,050 3/4	11,68	15,62	15,75	12,07	5,72	-	15,5	4,6	22,7	0,89	31,0	1,29	4,7,11,12
548 GL MA			25,400 1	17,02	25,40	25,60	15,88	8,28	-	24,0	5,4	36,1	2,10	72,0	3,29	4,7,11
548 GLS MA			25,400 1	17,02	25,40	25,60	15,88	8,28	-	21,0	5,4	36,1	2,10	72,0	2,90	4,7,11,12
563 GL MA			31,750 1 1/4	19,56	29,00	29,20	19,05	10,19	-	26,4	6,1	43,2	2,95	105,0	4,13	4,7,11,12
596 GL MA			38,100 1 1/2	25,40	37,90	38,10	25,40	14,63	-	33,4	6,6	53,4	5,54	180,0	7,34	4,7,11,12
455 GL-2 MA			9,525 3/8	5,72	8,53	8,66	6,35	3,28	10,24	8,2	3,3	23,8	0,56	17,4	0,86	4,7,11,12,15
462 GL-2 MA			12,700 1/2	7,75	11,30	11,43	8,51	4,45	13,92	11,5	3,9	31,0	1,01	37,0	1,50	4,7,11,12
501 GL-2 MA			15,875 5/8	9,65	13,28	13,41	10,16	5,08	16,59	14,2	4,1	36,2	1,34	54,0	2,00	4,7,11
513 GL-2 MA			19,050 3/4	11,68	15,62	15,75	12,07	5,72	19,46	15,5	4,6	42,2	1,79	63,0	2,62	4,7,11,12
548 GL-2 MA			25,400 1	17,02	25,40	25,60	15,88	8,28	31,88	24,0	5,4	68,0	4,21	140,0	5,83	4,7,11
563 GL-2 MA			31,750 1 1/4	19,56	29,00	29,20	19,05	10,19	36,45	26,4	6,1	79,7	5,81	210,0	8,03	4,7,11,12
596 GL-2 MA			38,100 1 1/2	25,40	37,92	38,10	25,40	14,63	48,36	33,4	6,6	101,8	11,09	360,0	14,47	4,7,11,12
455 GL-3 MA			9,525 3/8	5,72	8,53	8,66	6,35	3,28	10,24	8,2	3,3	34,0	0,81	24,9	1,30	4,7,11,12,15
462 GL-3 MA			12,700 1/2	7,75	11,30	11,43	8,51	4,45	13,92	11,5	3,9	44,9	1,51	56,0	2,21	4,7,11,12
501 GL-3 MA			15,875 5/8	9,65	13,28	13,41	10,16	5,08	16,59	14,2	4,1	52,8	2,02	80,0	2,97	4,7,11
513 GL-3 MA			19,050 3/4	11,68	15,62	15,75	12,07	5,72	19,46	15,5	4,6	61,7	2,68	94,0	3,43	4,7,11,12
548 GL-3 MA			25,400 1	17,02	25,40	25,60	15,88	8,28	31,88	24,0	5,4	99,9	6,31	211,0	8,25	4,7,11
563 GL-3 MA			31,750 1 1/4	19,56	29,00	29,20	19,05	10,19	36,45	26,4	6,1	116,1	8,87	300,0	11,66	4,7,11,12
596 GL-3 MA			38,100 1 1/2	25,40	37,90	38,10	25,40	14,63	48,36	33,4	6,6	150,2	16,63	523,0	22,00	4,7,11,12

Can also be supplied with attachments.

Chains 16-B GLS available with plate height g = 21 mm (max.) and as type series GL with g = 24 mm (max.)

Standard sprockets can be used for these chains.

Sprockets on request.

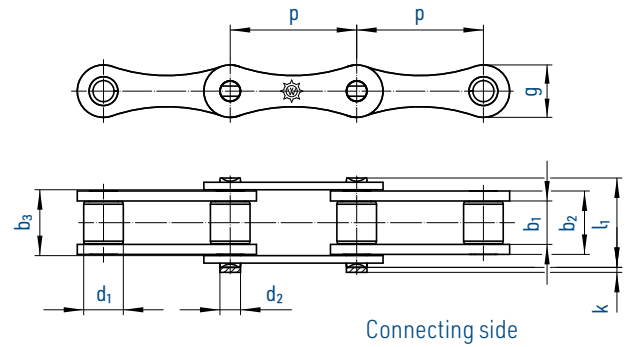

Chain according to ISO 1275		Pitch		Inner width	Inner link width	Outer plate width	Roller Ø	Pin Ø	Plate height	Projection over connecting link	Width over pin	Bearing area	Breaking load	Weight
⚙️		p		b ₁ min.	b ₂ max.	b ₃ min.	d ₁ max.	d ₂ max.	g max.	k max.	l ₁ max.	f	F _B min.	q ≈
No.	Ind.	mm	inch	mm	mm	mm	mm	mm	mm	mm	mm	cm ²	kN	kg/m
208 B MA		25,40	1	7,75	11,30	11,43	8,51	4,45	11,8	3,9	17,0	0,50	18,0	0,48
210 B MA		31,75	1 ¼	9,65	13,28	13,41	10,16	5,08	14,7	4,1	19,6	0,67	22,4	0,55
212 B MA		38,10	1 ½	11,68	15,62	15,75	12,07	5,72	16,1	4,6	22,7	0,89	29,0	0,80
216 B MA		50,80	2	17,02	25,45	25,58	15,88	8,28	21,0	5,4	36,1	2,10	60,0	1,74
220 B MA		63,50	2 ½	19,56	29,01	29,14	19,05	10,19	28,0	6,1	43,2	2,96	95,0	2,55

* g-measurement not according to standard

Sprockets for double pitch roller chains can be used for these chains.

Connecting links: According to ISO (...)



No. 4 (B)
Inner link



No. 7 (A)
Outer link
(to be riveted)



No. 111 (S)
Connecting link
with cottered pin



No. 11 (E)
for chain No. 713
with spring clip (E)



No. 12 (L)
Single
cranked link



Design E

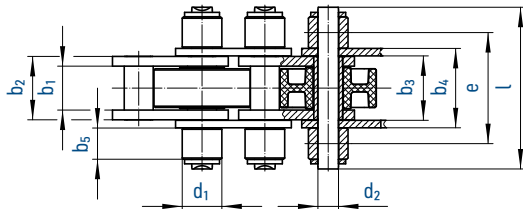
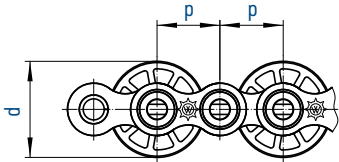

Double pitch chain Design L

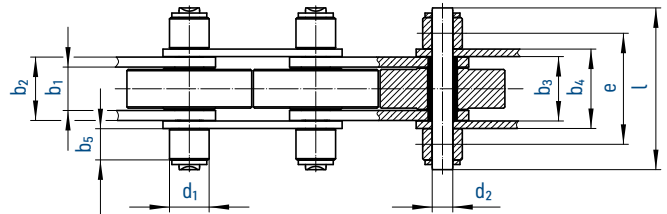
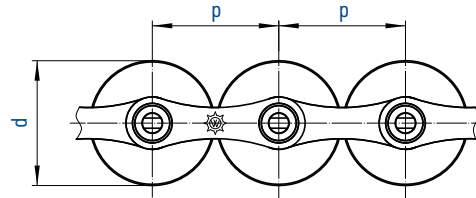

Chain	Pitch	Design	Inner width	Inner link width	Width		Support roller \varnothing	Pin \varnothing	Transverse pitch	Plate height	Width over pin	Support roller width	Width over pin Type l	Support roller width	
					between outer plates	over outer plates									
	p		b_1 min.	b_2 max.	b_3 min.	b_4 max.	d_1	d_2 max.	e	g max.	l max.	b_5 max.	l max.	b_5 max.	
No.	Ind.	mm	mm	mm	mm	mm	mm	mm	mm	mm	mm	mm	mm	mm	
513 SF MA		19,05	E	11,68	15,62	15,80	20,0	12,00	5,72	31,50	16,1	48,0	11,5	43,0	9,0
548 SF MA		25,40	E	17,02	25,45	25,81	32,0	15,88	8,28	44,50	21,0	65,0	12,5	-	-
722 SF MA		38,10	L	11,68	15,62	15,80	20,0	12,00	5,72	31,50	16,1	48,0	11,5	-	-
728 SF MA		50,80	L	17,02	25,45	25,81	32,0	15,88	8,28	44,50	21,0	65,0	12,5	-	-
D 513 SF MA		19,05	D	11,68	15,62	15,80	20,0	12,07	5,72	52,00	16,1	68,0	11,5	-	-
D 548 SF MA		25,40	D	17,02	25,45	25,81	32,0	15,88	8,28	76,76	21,0	97,0	12,5	-	-
T 513 SF MA		19,05	T	11,68	15,62	15,80	20,0	12,07	5,72	38,92	16,1	61,7	-	-	-
T 548 SF MA		25,40	T	17,02	25,45	25,81	32,0	15,88	8,28	63,76	21,0	99,9	-	-	-

Sprockets are available for all accumulator chains!

Connecting links with securing circlips.

Our connecting links always have the same length l as the ordinary pins.

Temperature range: - 30 to 100°C for steel conveyor rollers

- 10 to 60°C for plastic conveyor rollers

For information on AFS clips for optimal equipment and finger protection see page 75.



Design D

Design T

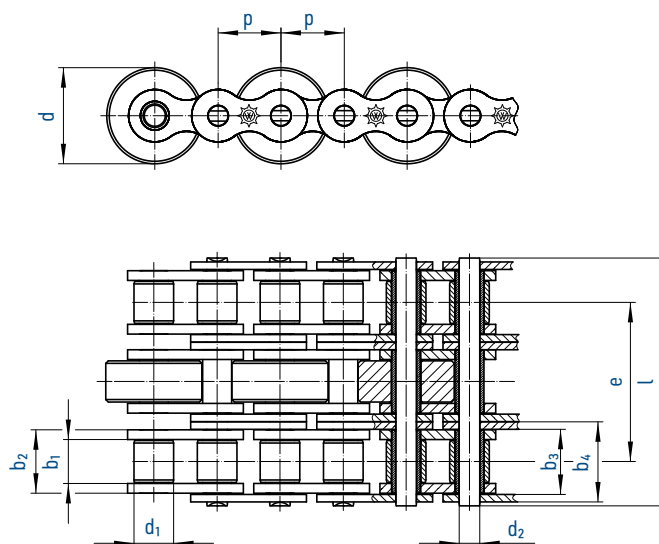
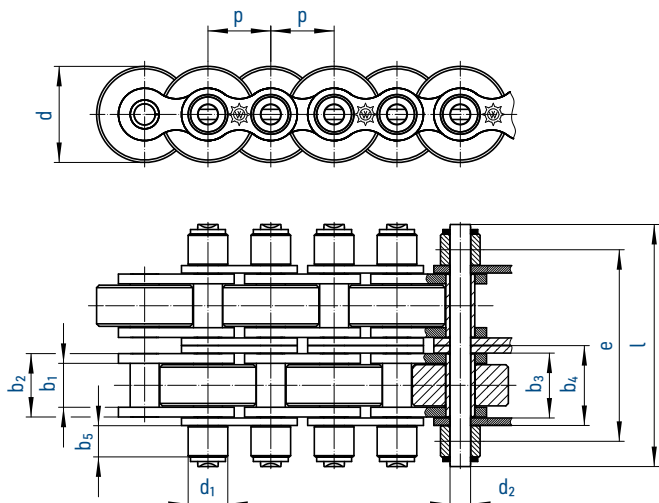

Width over pin Type II l max. mm.	Support roller width b ₅ max. mm.	Conveyor rollers						Breaking load F _B min. kN	Maximum load per m conveyor chain with 10 m conveyor length	
		Designation for material			Diameter				Steel	Plastic
		Steel	PA 6.6	Vestamide	d	Type I d	Type II d			
40,0	7,5	SF	SFK	SFV	24,0	26,0	28,0	29,0	300	260
-	-	SF	SFK	SFV	38,5	-	-	60,0	600	500
-	-	SF	SFK	SFV	24,0	26,0	28,0	29,0	300	260
-	-	SF	SFK	SFV	38,5	40,0	50,0	60,0	600	500
-	-	SF	SFK	SFV	24,0	26,0	28,0	57,8	600	520
-	-	SF	SFK	SFV	38,5	-	-	120,0	1200	1000
-	-	SF	SFK	SFV	24,0	26,0	28,0	60,0	600	260
-	-	SF	SFK	SFV	38,5	-	-	120,0	1200	500

The load per m applies for 10 m conveyor length per double chain strand. The load may be proportionally increased for shorter chain lengths and must be proportionally decreased for longer conveyor distances: e.g. 5 m conveyor distance = double load, 20 m conveyor distance = half load.

Maximum conveyor distances 25 - 30 m. The installation of guide plates is recommended as of 15 m. (see page 74).



High performance polymer bearing TRIGLEIT II



High performance polymer bearing TRIGLEIT Z

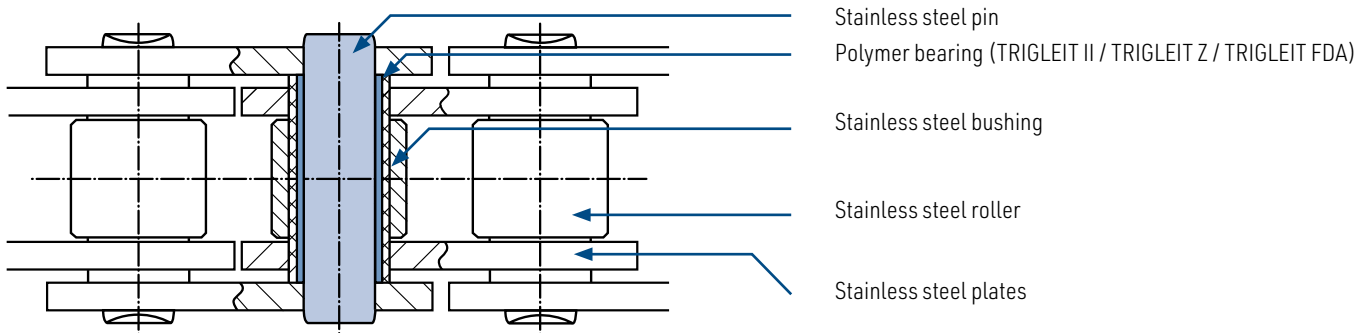

MARATHON stainless steel chains

For maximum freedom from maintenance and highest possible lifetime

High performance polymer bearings allow operation of stainless steel chains without relubrication!

Technical features

- Durable and low-friction polymer bearing
- All other chain components made of stainless steel grades
- Maximum chain speed $v = 2,5 \text{ m/s}$
- Working temperature -30°C to $+60^\circ\text{C}$ (TRIGLEIT II)
- Working temperature -100°C to $+200^\circ\text{C}$ (TRIGLEIT Z / TRIGLEIT FDA)
- Chain dimensions according to ISO 606; standard stainless steel sprockets can be used
- No relubrication required
- Relubrication with mineral oils possible (no ester oils)
- Can also be supplied with extended pins, straight attachments, bent attachments and in special designs
- Information on chemical resistance on request
- Durable water resistance (TRIGLEIT Z / TRIGLEIT FDA)

Application areas

- Packing industry
- Chemical industry
- Pharmaceutical industry
- Textile industry
- Food industry
- Sanitation industry
- Electrical industry

Results of long-term wear tests

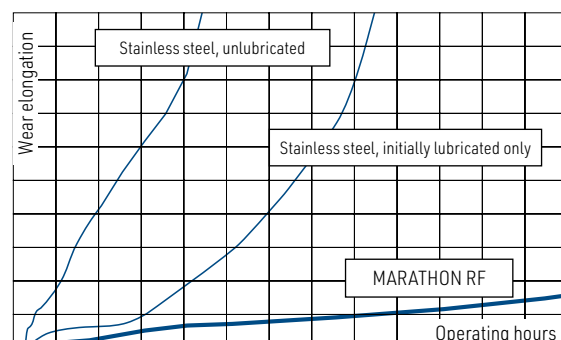



Simplex chains

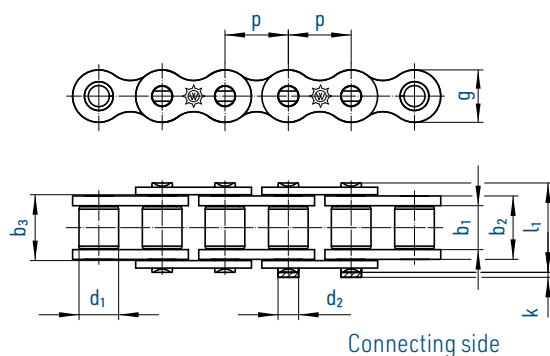

Simplex chains GL (straight plates)

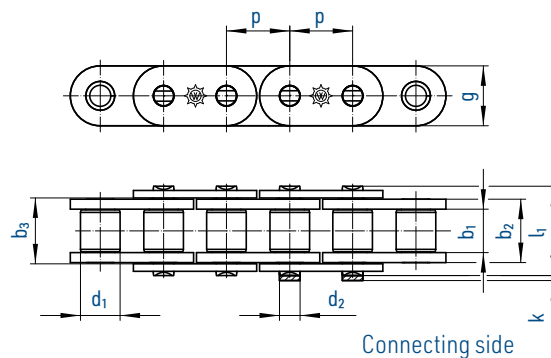

Duplex chains

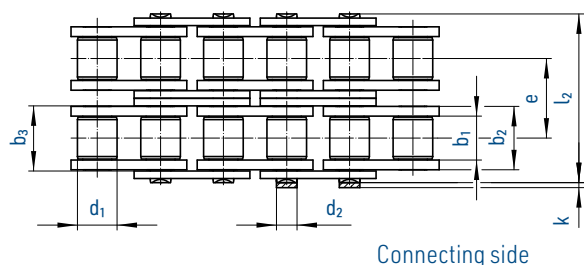

Triplex chains

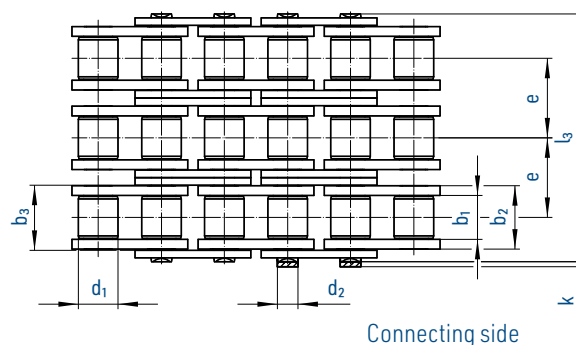

Chain		ISO	Pitch		Inner width b_1 min.	Inner link width b_2 max.	Outer plate width b_3 min.	Roller \emptyset d_1 max.	Pin \emptyset d_2 max.	Transverse pitch e	Plate height g max.	Projection over connecting link k max.	Width over pin l max.	Bearing area f cm^2	Breaking load F_B min.	Weight q kg/m	Connecting links
No.	Ind.		Nr.	mm													
462	RF MA	08 B-1	12,700	1/2	7,75	11,30	11,43	8,51	4,45	-	11,8	3,9	17,0	0,50	12,00	0,70	11,12,15
501	RF MA	10 B-1	15,875	5/8	9,65	13,28	13,41	10,16	5,08	-	14,7	4,1	19,6	0,67	14,50	0,91	11,12,15
513	RF MA	12 B-1	19,050	3/4	11,68	15,62	15,75	12,07	5,72	-	16,1	4,6	22,7	0,89	18,50	1,18	11,12,15
548	RF MA	16 B-1	25,400	1	17,02	25,40	25,60	15,88	8,28	-	21,0	5,4	36,1	2,10	40,00	2,50	111,12
563	RF MA	20 B-1	31,750	1 1/4	19,56	29,00	29,20	19,05	10,19	-	26,4	6,1	43,2	2,96	63,00	3,50	11,12
D 462	RF MA	08 B-2	12,700	1/2	7,75	11,30	11,43	8,51	4,45	13,92	11,8	3,9	31,0	1,01	20,40	1,36	11,12,15
D 501	RF MA	10 B-2	15,875	5/8	9,65	13,28	13,41	10,16	5,08	16,59	14,7	4,1	36,2	1,34	24,65	1,82	11,12,15
D 513	RF MA	12 B-2	19,050	3/4	11,68	15,62	15,75	12,07	5,72	19,46	16,1	4,6	42,2	1,79	31,45	2,38	11,12,15
D 548	RF MA	16 B-2	25,400	1	17,02	25,40	25,60	15,88	8,28	31,88	21,0	5,4	68,0	4,21	68,00	5,10	111,12
D 563	RF MA	20 B-2	31,750	1 1/4	19,56	29,00	29,20	19,05	10,19	36,45	26,4	6,1	79,7	5,91	107,10	7,30	11,12
T 462	RF MA	08 B-3	12,700	1/2	7,75	11,30	11,43	8,51	4,45	13,92	11,8	3,9	44,9	1,51	32,50	2,01	11,12,15
T 501	RF MA	10 B-3	15,875	5/8	9,65	13,28	13,41	10,16	5,08	16,59	14,7	4,1	52,8	2,02	39,00	2,70	11,12,15
T 513	RF MA	12 B-3	19,050	3/4	11,68	15,62	15,75	12,07	5,72	19,46	16,1	4,6	61,7	2,68	49,50	3,12	11,12,15
T 548	RF MA	16 B-3	25,400	1	17,02	25,40	25,60	15,88	8,28	31,88	21,0	5,4	99,9	6,31	108,00	7,50	111,12
T 563	RF MA	20 B-3	31,750	1 1/4	19,56	29,00	29,20	19,05	10,19	36,45	26,4	6,1	116,1	8,87	170,00	10,60	11,12

Can also be supplied with attachments, straight plates (type series GL) and as double pitch roller chains (dimensions according to ISO 1275). Chains 548 available as type series GLS with plate height $g = 21$ mm (max.) and as type series GL with $g = 24$ mm (max.). Sprockets on request.

Connecting links: According to ISO (...)



No. 4 (B)
Inner link



No. 7 (A)
Outer link
(to be riveted)



No. 11 (E)
Spring clip
connecting link



No. 111 (S)
Connecting link
with cottered pin



No. 12 (L)
Single
cranked link



No. 15 (C)
Double
cranked link

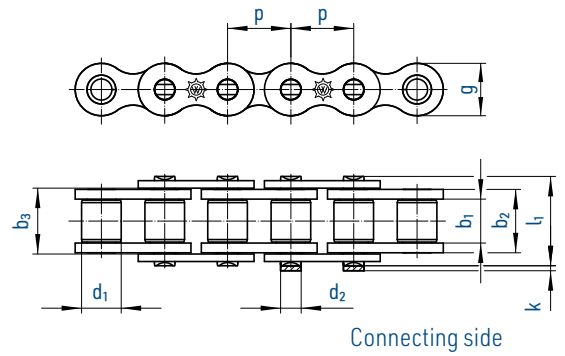

Chain according to ISO 606		Pitch	Inner width	Inner link width	Outer plate width	Roller Ø	Pin Ø	Plate height	Projection over connecting link	Width over pin	Bearing area	Breaking load	Weight	Connecting links
⚙️		p	b ₁ min.	b ₂ max.	b ₃ min.	d ₁ max.	d ₂ max.	g max.	k max.	l ₁ max.	f	F _B min.	q ≈	
No.	Ind.	mm	mm	mm	mm	mm	mm	mm	mm	mm	cm ²	kN	kg/m	No.
450 RF	^{10,11}	8,00	3,00	4,77	4,90	5,00	2,31	7,1	3,1	8,6	0,11	4,0	0,18	11
331 RF	^{10,11}	12,70	3,30	5,80	5,93	7,75	3,66	9,9	1,5	10,2	0,21	7,0	0,28	11,15
332 RF	^{10,11}	12,70	4,88	7,20	7,33	7,75	3,66	9,9	1,5	11,2	0,28	7,0	0,33	11,15
462 RF		12,70	7,75	11,30	11,43	8,51	4,45	11,8	3,9	17,0	0,50	12,0	0,70	11,12,15
501 RF		15,88	9,65	13,28	13,41	10,16	5,08	14,7	4,1	19,6	0,67	14,5	0,91	11,12,15
513 RF		19,05	11,68	15,62	15,75	12,07	5,72	16,1	4,6	22,7	0,89	18,5	1,18	11,12,15
548 RF	¹¹	25,40	17,02	25,40	25,60	15,88	8,28	21,0	5,4	36,1	2,10	40,0	2,50	111,12
563 RF	¹¹	31,75	19,56	29,00	29,20	19,05	10,19	26,4	6,1	43,2	2,96	63,0	3,50	111,12
35 RF	^{2,11}	9,53	4,68	7,47	7,52	5,08	3,58	9,1	3,3	13,2	0,27	6,0	0,35	11
40 RF	^{10,11}	12,70	7,85	11,15	11,28	7,95	3,96	12,0	3,9	17,8	0,44	10,5	0,61	11,12,15
60 RF	¹¹	19,05	12,57	17,70	17,85	11,91	5,94	18,0	4,6	26,9	1,05	20,0	1,58	11,12
455 RFGL	^{10,11}	9,53	5,72	8,53	8,66	6,35	3,28	8,2	3,3	13,5	0,28	7,0	0,41	11,12,15
455 RFKIGL	^{2,7}	9,53	5,72	8,53	8,66	6,35	3,28	8,2	3,3	13,5	0,28	1,0	0,25	11
462 RFKI	^{2,7}	12,70	7,75	11,30	11,43	8,51	4,45	11,5	3,9	17,0	0,50	2,0	0,44	11
462 RFGL	²	12,70	7,75	11,30	11,43	8,51	4,45	11,5	3,9	17,0	0,50	12,0	0,78	11,12,15
501 RFGL		15,88	9,65	13,28	13,41	10,16	5,08	14,2	4,1	19,6	0,67	14,5	1,03	11,12,15
513 RFGL		19,05	11,68	15,62	15,75	12,07	5,72	15,5	4,6	22,7	0,89	18,5	1,29	11,12,15
548 RFGL	¹¹	25,40	17,02	25,40	25,60	15,88	8,28	24,0	5,4	36,1	2,10	40,0	3,29	111
548 RFGLS	¹¹	25,40	17,02	25,40	25,60	15,88	8,28	21,0	5,4	36,1	2,10	40,0	2,90	111,12
563 RFGL	¹¹	31,75	19,56	29,00	29,20	19,05	10,19	26,4	6,1	43,2	2,96	63,0	4,13	111

² without rollers (DIN 8154) ⁷ inner links made entirely of plastic, maintenance-free chain ¹⁰ connecting link No.12 only with attached riveted bolts
¹¹ sprockets on request

Roller chains RF (stainless steel) - type series GL (straight plates) can also be supplied as multiplex roller chains. For details on orders and enquiries see page 148. For sprockets RF (stainless steel) see page 100.

Connecting links: According to ISO (...)



No. 4 (B)
Inner link

No. 7 (A)
Outer link
(to be riveted)

No. 11 (E)
Spring clip
connecting link

No. 111 (S)
Connecting link
with cottered pin

No. 12 (L)
Single
cranked link

No. 15 (C)
Double
cranked link

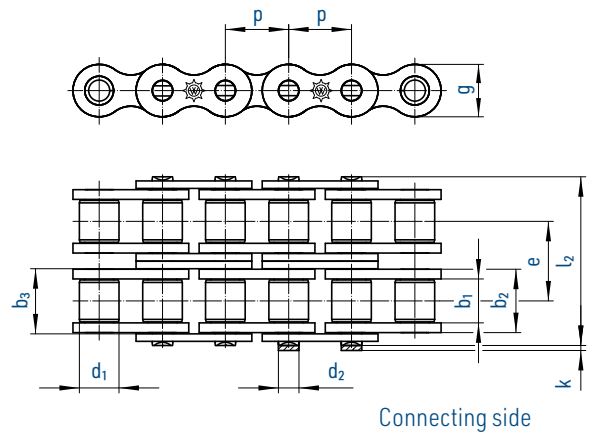

Chain according to ISO 606		Pitch	Inner width	Inner link width	Outer plate width	Roller Ø	Pin Ø	Transverse pitch	Plate height	Projection over connecting link	Width over pin	Bearing area	Breaking load	Weight	Connecting links
⚙️		p	b ₁ min.	b ₂ max.	b ₃ min.	d ₁ max.	d ₂ max.	e	g max.	k max.	l ₂ max.	f	F _B min.	q ≈	No.
No.	Ind.	mm	mm	mm	mm	mm	mm	mm	mm	mm	mm	cm ²	kN	kg/m	No.
D450 RF		8,000	3,00	4,77	4,90	5,00	2,31	5,64	7,1	3,1	14,3	0,22	6,00	0,36	11,15
D455 RF	¹	9,525	5,72	8,53	8,66	6,35	3,28	10,24	8,2	3,3	23,8	0,56	11,90	0,78	11,15
D462 RF		12,700	7,75	11,30	11,43	8,51	4,45	13,92	11,8	3,9	31,0	1,01	20,40	1,36	11,12,15
D501 RF		15,875	9,65	13,28	13,41	10,16	5,08	16,59	14,7	4,1	36,2	1,34	24,65	1,82	11,12,15
D513 RF		19,050	11,68	15,62	15,75	12,07	5,72	19,46	16,1	4,6	42,2	1,79	31,45	2,38	11,12,15
D548 RF		25,400	17,02	25,40	25,60	15,88	8,28	31,88	21,0	5,4	68,0	4,21	68,00	5,10	11,12
D563 RF		31,750	19,56	29,00	29,20	19,05	10,19	36,45	26,4	6,1	79,7	5,91	107,10	7,30	11,12
40-2 RF		12,700	7,85	11,15	11,28	7,95	3,96	14,38	12,0	3,9	32,3	0,88	17,85	1,20	11,12
60-2 RF		19,050	12,57	17,70	17,85	11,91	5,94	22,78	18,0	4,6	49,8	2,10	34,00	3,14	11,12

¹ with straight side plates

For details on orders and enquiries see page 148. Sprockets on request.

Connecting links: According to ISO (...)



No. 4 (B)
Inner link



No. 7 (A)
Outer link
(to be riveted)



No. 11 (E)
Spring clip
connecting link



No. 111 (S)
Connecting link
with cottered pin



No. 12 (L)
Single
cranked link



No. 15 (C)
Double
cranked link

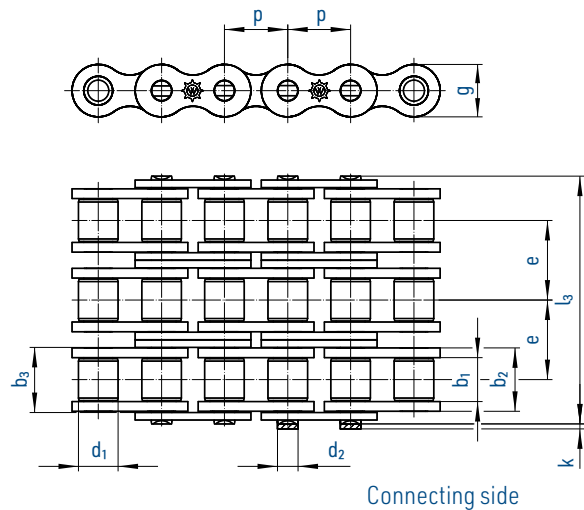
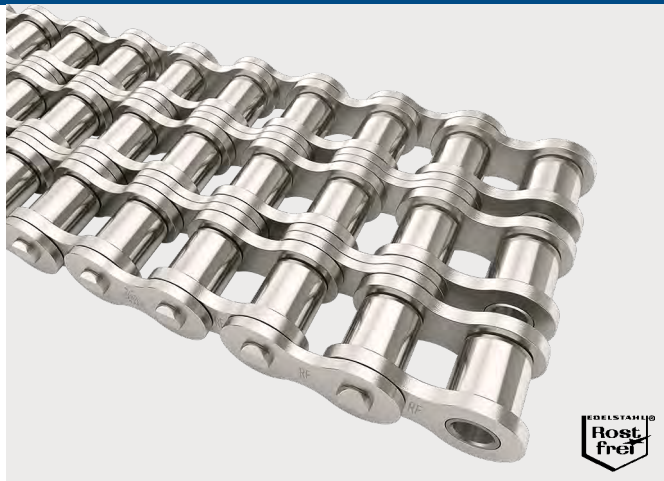

Chain according to ISO 606		Pitch		Inner width	Inner link width		Outer plate width	Roller Ø	Pin Ø	Transverse pitch	Plate height	Projection over connecting link	Width over pin	Bearing area	Breaking load	Weight	Connecting links
⚙️		p		b ₁ min.	b ₂ max.	b ₃ min.	d ₁ max.	d ₂ max.	e	g max.	k max.	l ₃ max.	f	F _B min.	q ≈		
No.	Ind.	mm	inch	mm	mm	mm	mm	mm	mm	mm	mm	mm	mm	cm ²	kN	kg/m	No.
T 455 RF	¹	9,525	3/8	5,72	8,53	8,66	6,35	3,28	10,24	8,2	3,3	34,0	0,81	18,9	1,18	11,12,15	
T 462 RF		12,700	1/2	7,75	11,30	11,43	8,51	4,45	13,92	11,8	3,9	44,9	1,51	32,5	2,01	11,12,15	
T 501 RF		15,875	5/8	9,65	13,28	13,41	10,16	5,08	16,59	14,7	4,1	52,8	2,02	39,0	2,70	11,12,15	
T 513 RF		19,050	3/4	11,68	15,62	15,75	12,07	5,72	19,46	16,1	4,6	61,7	2,68	49,5	3,12	11,12,15	
T 548 RF		25,400	1	17,02	25,40	25,60	15,88	8,28	31,88	21,0	5,4	99,9	6,31	108,0	7,50	111,12	
T 563 RF		31,750	1 1/4	19,56	29,00	29,20	19,05	10,19	36,45	26,4	6,1	116,1	8,87	170,0	10,60	111,12	

¹ with straight side plates

For details on orders and enquiries see page 148, Sprockets on request.
Information on the selection of chain sizes and drives as of page 136.

Connecting links: According to ISO (...)



No. 4 (B)
Inner link



No. 7 (A)
Outer link
(to be riveted)



No. 11 (E)
Spring clip
connecting link



No. 111 (S)
Connecting link
with cottered pin



No. 12 (L)
Single
cranked link



No. 15 (C)
Double
cranked link

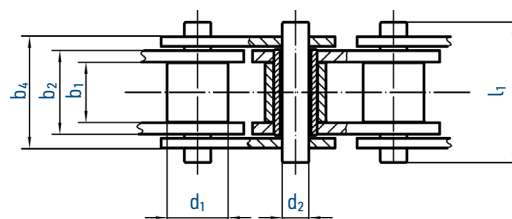
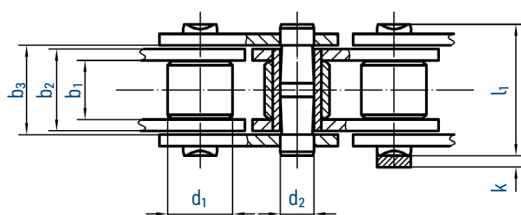
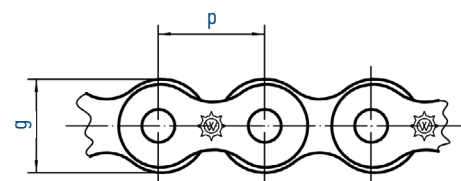
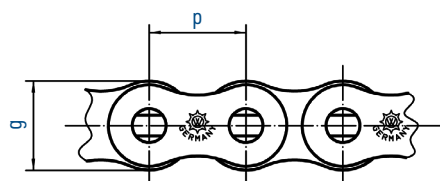
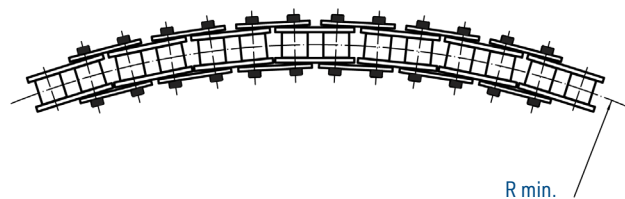

Main dimensions according to ISO 606 (European type)

Chain		Pitch	Inner width	Inner link width	Outer plate width	Roller \emptyset	Pin \emptyset	Plate height	Projection over connecting link	Width over pin	Bearing area	Breaking load	Smallest possible side bow radius
		p	b ₁ min.	b ₂ max.	b ₃ min.	d ₁ max.	d ₂ max.	g max.	k max.	l ₁ max.	f	F _B min.	r min.
No.	Ind.	mm	mm	mm	mm	mm	mm	mm	mm	mm	cm ²	kN	mm
462 SB		12,700	7,75	11,30	11,70	8,51	4,45	11,80	3,90	17,20	0,08	17,8	300
501 SB		15,875	9,65	13,28	13,70	10,16	5,08	14,70	4,10	19,60	0,09	22,2	400
513 SB		19,050	11,68	15,62	16,10	12,07	5,72	16,10	4,60	22,70	0,12	28,9	450
548 SB		25,400	17,02	25,40	27,20	15,88	8,28	21,00	5,40	37,40	0,21	60,0	500

Main dimensions according to ISO 606 (American type)

Chain		Pitch	Inner width	Inner link width	Outer plate width	Roller \emptyset	Pin \emptyset	Plate height	Projection over connecting link	Width over pin	Bearing area	Breaking load	Smallest possible side bow radius
		p	b ₁ min.	b ₂ max.	b ₄ min.	d ₁ max.	d ₂ max.	g max.	k max.	l ₁ max.	f	F _B min.	r min.
No.	Ind.	mm	mm	mm	mm	mm	mm	mm	mm	mm	cm ²	kN	mm
ASA 40		12,70	7,85	11,17	14,40	7,95	3,45	12,00		18,20	0,38	10,5	250
ASA 40 RF		12,70	7,85	11,17	14,40	7,95	3,45	12,00		18,20	0,38	6,3	250
ASA 61	¹	19,05	13,00	17,70	22,70	11,91	5,08	15,90		29,10	0,89	28,0	400
ASA 61 RF	¹	19,05	13,00	17,70	22,70	11,91	5,08	15,90		29,10	0,89	15,0	400

¹ with straight inner plate



POM-Clips

The best protection for sensitive goods

These clips are suitable for mounting on roller chains (type series GL) and prevent the direct contact between the chain and the items to be transported. Furthermore, they enlarge the contact surface and they are therefore able to guarantee a particularly safe conveyance process.

The special design of the plastic clips also prevents a possible tilting in the deflections of the chain conveyor. In order to strengthen the clip fixing even more and thus increase safety, WIPPERMANN recommends the use of unriveted roller chains.

Technical features

- Stiff and durable thermoplastic
- Impact resistant
- Wear resistant
- Friction coefficient $\mu = 0,15 \dots 0,3$ (against steel)
- Max. sustained temperature 80°C
- Food approved
- Alkali-proof
- Hot-water-proof
- Not resistant against strong acids (pH < 4)
- Insoluble in many solvents, fuel and mineral oil
- Low bulking

Roller chains (Type GL) with POM-Clip

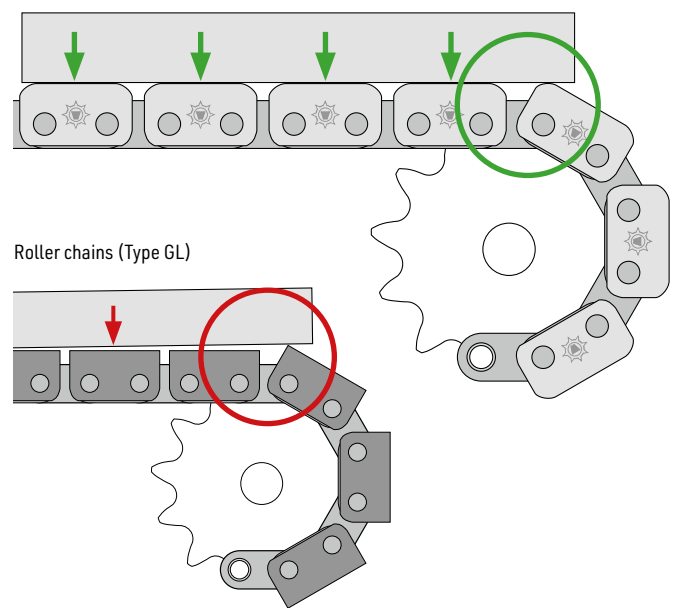

Roller chains (Type GL)

Benefits for application

- For simplex and duplex roller chains
- Protect sensitive goods from damage by the chain
- Wear resistant and durable POM
- No edge pressure at transfer points (see picture)
- High load capacity per clip
- Black clips for connecting links (mounting without spring clip)

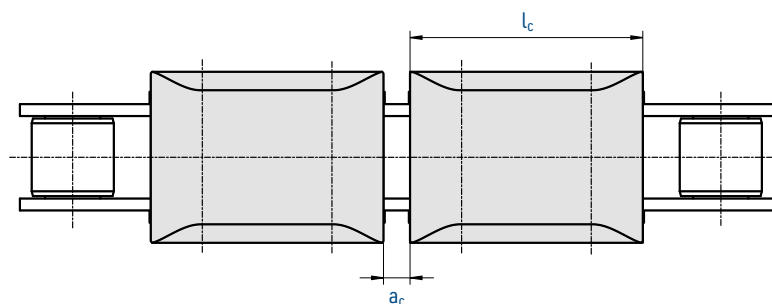
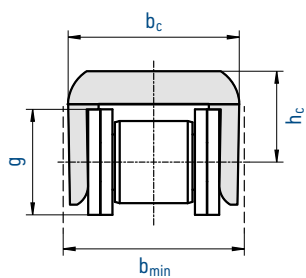

Chain			Plate height						max. vertical load per clip
☙		ISO	g	a _c	b _c	b _{min}	h _c	l _c	
No.	Ind.	Nr.	mm	mm	mm	mm	mm	mm	kg
462 GL		08 B-1	11,5	3,50	19,7	22,0	9,3	21,9	70
D 462 GL		08 B-2	11,5	3,50	33,7	36,0	9,3	21,9	140
501 GL		10 B-1	14,2	1,55	22,6	25,0	12,5	30,2	90
D 501 GL		10 B-2	14,2	1,55	39,3	42,0	12,5	30,2	180
513 GL		12 B-1	15,5	3,90	25,4	28,0	13,2	34,2	110
D 513 GL		12 B-2	15,5	3,90	45,3	48,0	13,2	34,2	220
548 GLS		16 B-1	21,0	5,10	40,5	45,0	18,5	45,7	140
548 GL		factory standard	24,0	5,10	40,5	45,0	18,5	45,7	140
548 R	³¹	16 B-1	21,0	1,8	40,5	45,0	16,0	49,0	140
563 GL		20 B-1	26,5	10,4	47,0	50,0	20,0	53,4	180

³¹ 31 PA6-GF30 light grey, for waisted plates chains

Assembly of the clips at room temperature (> 15°C)

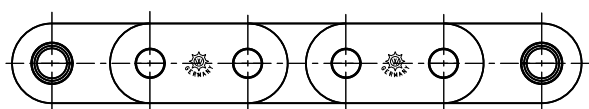

Correct chain for plastic clips
(Type series GL, preferably unriveted)

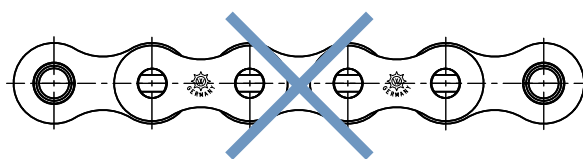

Wrong chain for plastic clips

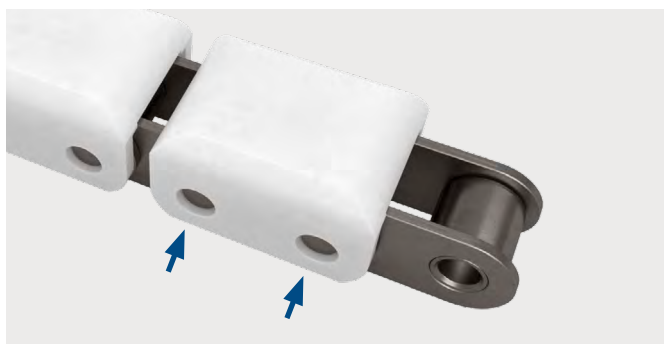

Fixing by pin extensions, chains preferably unriveted

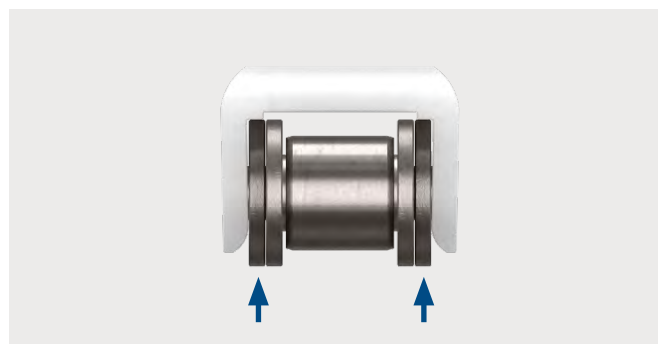

Top surface of the straight plates bear the load

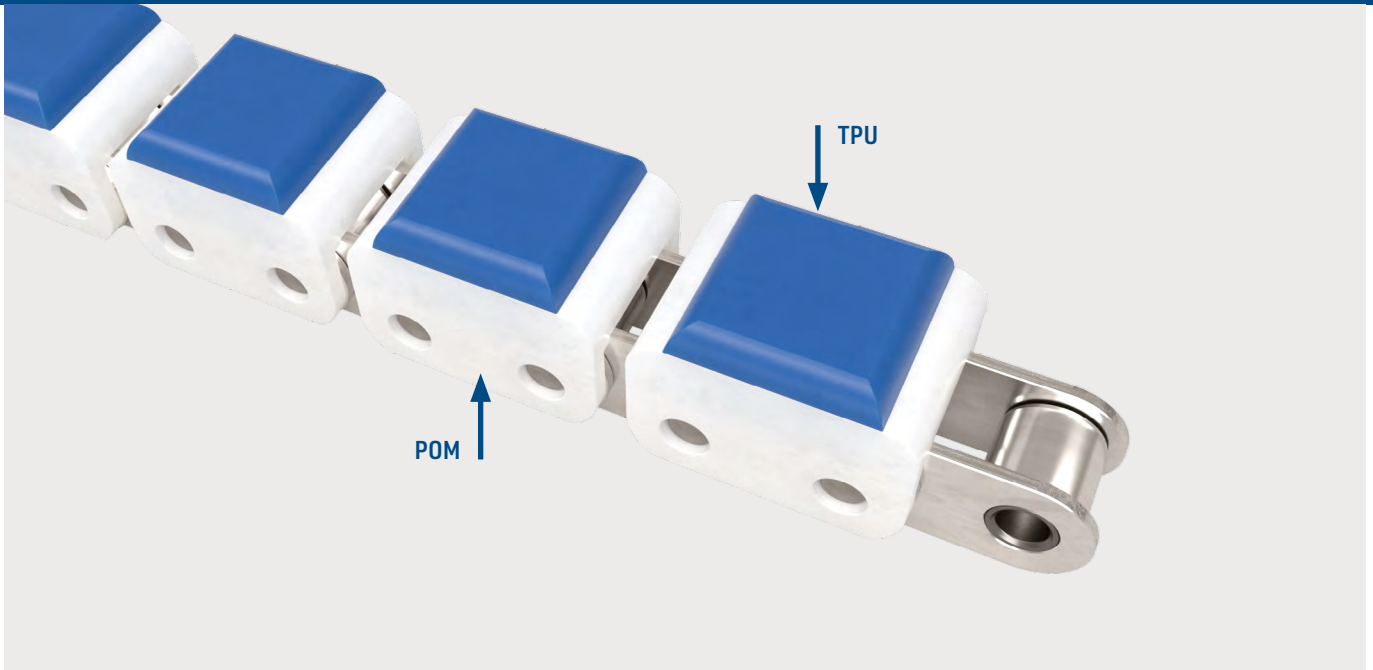

POM-Clips with elastomer

Slip-free conveyance process

For the conveyance of particularly delicate goods as well as for goods that slip easily, WIPPERMANN offers plastic clips with an overlay made of thermo-plastic elastomer (TPU) with a hardness of approximately 85 Shore A.

These clips significantly increase the adhesion friction coefficient between the conveyed item and the clip, and they can therefore ensure an absolutely slip-free conveyance process. On customers' request, hardness grades between 50 Shore A and 90 Shore A can be supplied.

Technical features

- POM-Clip: stiff, durable, impact resistant
- TPU-top: 85 Shore A
- Perfect junction between POM-Clip and TPU-top
- High friction, high abrasion resistance
- Max. sustained temperature 80°C
- Resistant against most oils and greases
- Low danger of hydrolysis

Benefits for application

- For chain 462GL, 513GL, 548GLS including MARATHON and Stainless Steel
- Basic clip POM, top surface TPU (85 Shore A)
- Protect sensitive goods from damage by the chain
- No edge pressure at transfer points (see picture)
- High coefficient of friction between clip and conveyed good
- High load capacity
- Mounting of connecting links with POM-clip and without spring clip

Roller chain (type GL) with POM clip including TPU overlay

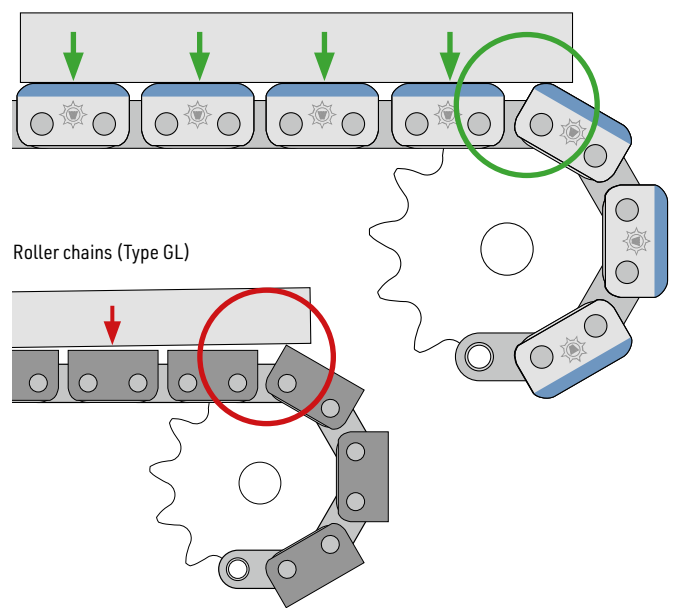

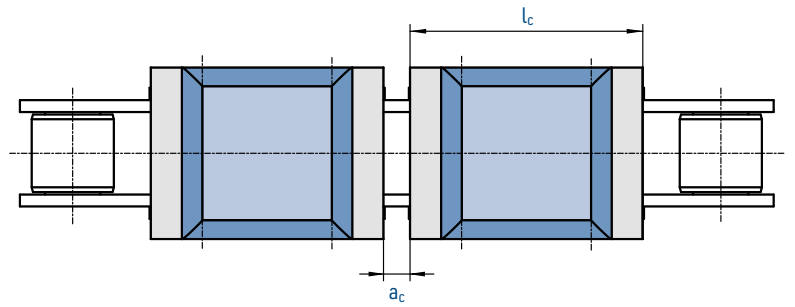
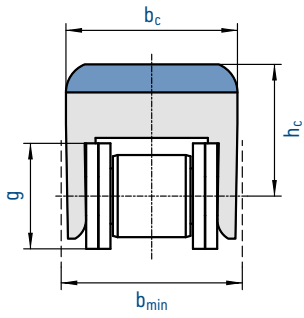

Chain			Plate height						max. vertical load per clip
⚙️		ISO	g	a _c	b _c	b _{min}	h _c	l _c	
No.	Ind.	Nr.	mm	mm	mm	mm	mm	mm	kg
462 GL		08 B-1	11,5	3,4	19,5	22,0	13,0	21,9	70
513 GL		12 B-1	15,5	3,9	25,4	28,0	20,0	34,2	110
548 GLS		16 B-1	21,0	5,1	40,5	45,0	21,5	45,7	140

Assembly of the clips at room temperature (> 15°C)
Connectors consisting of no. 7 and connecting plate.

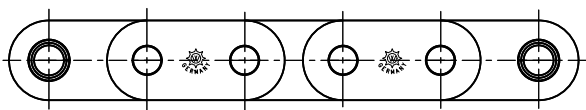

Correct chain for plastic clips
(Type series GL, preferably unriveted)

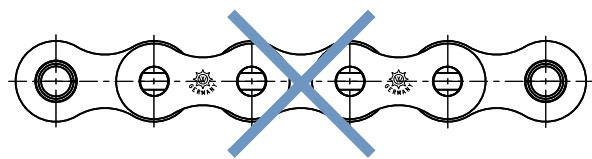

Wrong chain for plastic clips

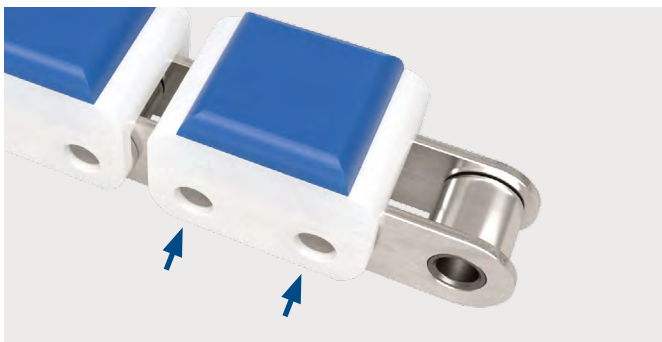

Fixing by pin extension, preferably chains unriveted or with extended pins



Top surfaces of the straight plates bear the load

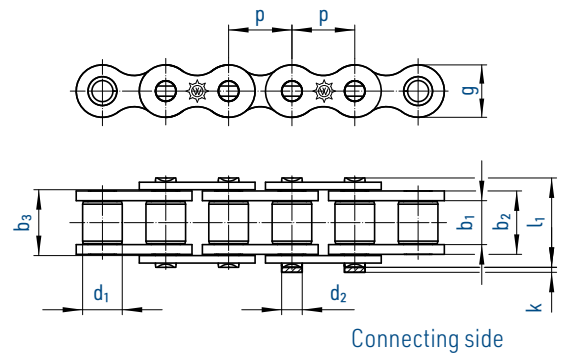
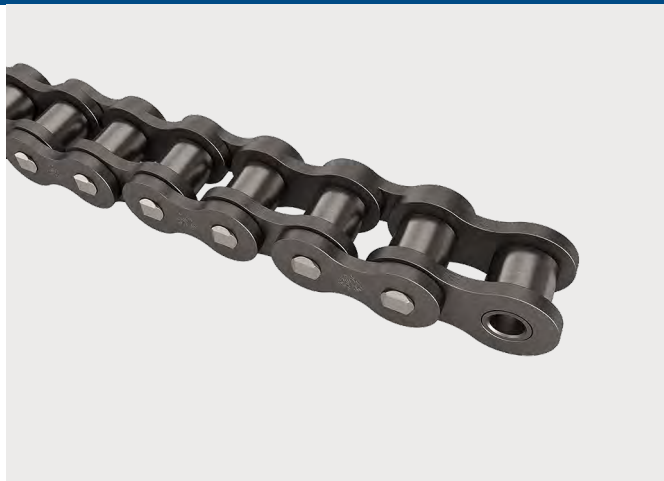

Chain		Pitch		Inner width	Inner link width	Outer plate width	Roller Ø	Pin Ø	Plate height	Projection over connecting link	Width over pin	Bearing area	Breaking load	Weight	Connecting links
⚙️		p		b ₁ min.	b ₂ max.	b ₃ min.	d ₁ max.	d ₂ max.	g max.	k max.	l ₁ max.	f	F _B min.	q ≈	
No.	Ind.	mm	inch	mm	mm	mm	mm	mm	mm	mm	mm	cm ²	kN	kg/m	No.
455 TL		9,525	3/8	5,72	8,53	8,66	6,35	3,28	9,0	3,3	13,5	0,28	9,0	0,41	4,7,11,12,15
18		12,700	1/2	4,88	9,30	9,43	7,75	4,18	11,2	1,5	14,4	0,39	17,5	0,55	4,7,11,12,15
460		12,700	1/2	5,21	8,70	8,93	8,51	4,45	11,8	3,9	15,0	0,39	18,2	0,62	4,7,11,15
515		19,050	3/4	13,50	19,70	19,83	12,07	5,72	16,2	4,6	28,6	1,12	35,0	1,67	4,7,11,12
517		19,050	3/4	11,68	17,00	17,13	12,07	6,10	18,1	3,6	24,9	1,05	40,0	1,51	4,7,11,12
546 b		25,400	1	12,70	20,00	20,20	14,00	7,50	22,5	5,4	30,0	1,48	58,0	2,14	4,7,11,12
547		25,400	1	12,70	21,07	21,27	15,88	8,28	21,0	5,4	30,9	1,74	63,0	2,50	4,7,11,12,111
577		35,000	-	19,60	27,00	27,20	19,05	10,19	26,0	6,1	40,0	2,74	85,0	2,90	4,7,11,12
6144	¹	41,500	-	20,70	26,90	27,28	15,90	9,05	26,3	5,0	38,1	2,40	56,0	2,59	4,7,111

¹ with straight side plates

For new installations we recommend to use only standardised roller chains according to ISO 606!
We reserve the right to cease production of this type series without prior notice!

For details on orders and enquiries see page 148. Sprockets on request.

Connecting links: According to ISO (...)





Simplex chains

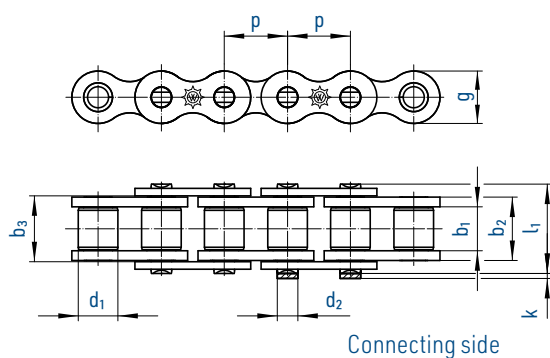

Simplex chains GL (straight plates)

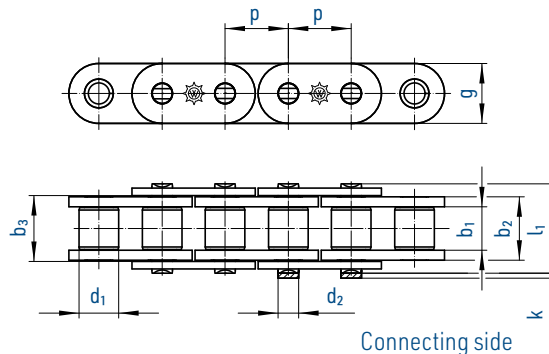

Duplex chains

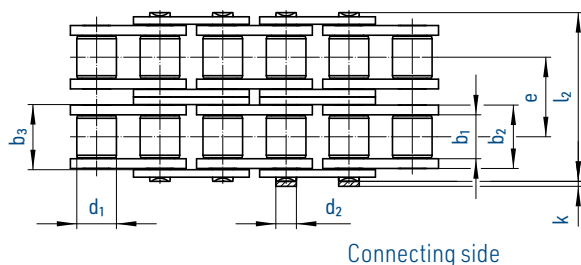

Triplex chains

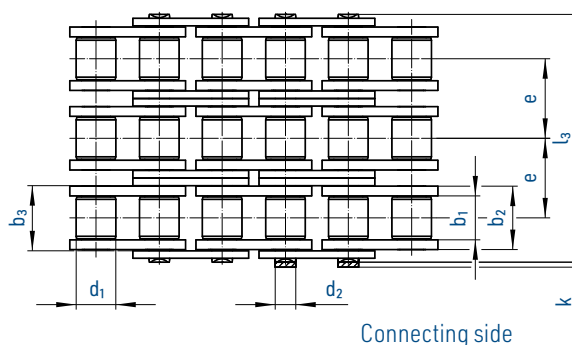

Chain		Pitch		Inner width	Inner link width	Outer plate width	Roller Ø	Pin Ø	Transverse pitch	Plate height	Projection over connecting link	Width over pin	Bearing area	Breaking load	Weight	Connecting links
⚙		p		b ₁ min.	b ₂ max.	b ₃ min.	d ₁ max.	d ₂ max.	e	g max.	k max.	l max.	f	F _B min.	q ≈	
No.	Ind.	mm	inch	mm	mm	mm	mm	mm	mm	mm	mm	mm	cm ²	kN	kg/m	No.
548 GLX	1	25,400	1	17,02	25,40	25,60	15,88	8,28	-	24,0	5,4	36,1	2,10	85,0	3,29	4,7,11,111
D548 GLX	1	25,400	1	17,02	25,40	25,60	15,88	8,28	31,88	24,0	5,4	68,0	4,21	170,0	6,59	4,7,11,111
T548 GLX	1	25,400	1	17,02	25,40	25,60	15,88	8,28	31,88	24,0	5,4	99,9	6,31	270,0	8,50	4,7,11,111
563 GLX	1	31,750	1 ¼	19,56	29,00	29,20	19,05	10,19	-	26,4	6,1	43,2	2,95	123,0	4,13	4,7,11,111
D563 GLX	1	31,750	1 ¼	19,56	29,00	29,20	19,05	10,19	36,45	26,4	6,1	79,0	5,91	240,0	8,03	4,7,11,111
T563 GLX	1	31,750	1 ¼	19,56	29,00	29,20	19,05	10,19	36,45	26,4	6,1	116,0	8,87	350,0	11,66	4,7,11,111
596 R		38,100	1 ½	25,40	37,90	38,20	25,40	13,50	-	36,0	6,6	53,4	5,12	200,0	7,10	4,7,111
596 SX		38,100	1 ½	25,40	39,90	40,20	25,40	14,63	-	36,0	6,6	56,5	5,84	235,0	8,20	4,7,111
50 HX	14	15,875	5/8	9,40	14,60	14,73	10,16	5,08	-	15,0	4,1	23,4	0,75	33,4	1,18	4,7,11
60 HX	14	19,050	¾	12,57	19,45	19,60	11,91	5,94	-	18,0	4,6	28,9	1,16	50,0	1,94	4,7,11
80 HX	14	25,400	1	15,75	24,28	24,49	15,88	7,92	-	24,1	5,4	37,0	1,92	75,6	3,04	4,7,111
100 HX	14	31,750	1 ¼	18,90	29,10	29,30	19,05	9,53	-	30,1	6,1	44,0	2,77	113,4	4,25	4,7,111
120 HX	14	38,100	1 ½	25,22	37,18	37,50	22,23	11,10	-	36,2	6,6	54,0	4,13	182,4	6,80	4,7,111

¹ with straight side plates ¹⁴ Type series HX with reinforced plates and pins made of quenched and tempered steel

For details on orders and enquiries see page 148. Sprockets on request.

Connecting links: According to ISO (...)



No. 4 (B)
Inner link



No. 7 (A)
Outer link
(to be riveted)



No. 11 (E)
Spring clip
connecting link



No. 111 (S)
Connecting link
with cottered
pin

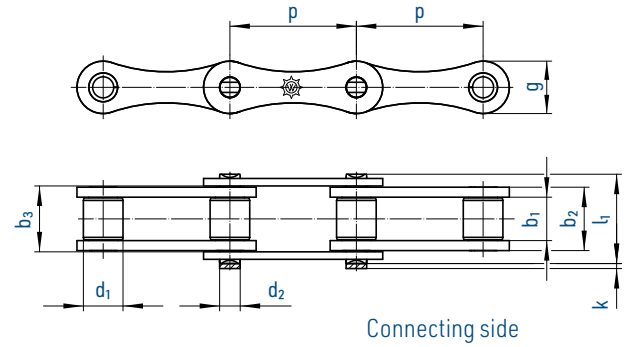

Chain			Pitch		Inner width	Inner link width	Outer plate width	Roller Ø	Pin Ø	Plate height	Projection over connecting link	Width over pin	Bearing area	Breaking load ISO	Weight
No.	Ind.	ISO Nr.	mm	inch	b_1 min.	b_2 max.	b_3 min.	d_1 max.	d_2 max.	g max.	k max.	l_1 max.	f	F_B min.	$q \approx$
713		208 B	25,40	1	7,75	11,30	11,43	8,51	4,45	11,8	3,9	17,0	0,50	18,0	0,46
717		210 B	31,75	1 ¼	9,65	13,28	13,41	10,16	5,08	14,7	4,1	19,6	0,67	22,4	0,57
722		212 B	38,10	1 ½	11,68	15,62	15,75	12,07	5,72	16,1	4,6	22,7	0,89	29,0	0,75
728		216 B	50,80	2	17,02	25,40	25,60	15,88	8,28	21,0	5,4	36,1	2,10	60,0	1,74
734	*	220 B	63,50	2 ½	19,56	29,00	29,20	19,05	10,19	28,5	6,1	43,2	2,96	95,0	2,55

Electrogalvanised or nickel-plated chains on request. In this case chains may only have 80 % of the tensile strength.

* g-measurement not according to standard

Double pitch roller chains (stainless steel)

713 RF		208 B	25,40	1	7,75	11,30	11,43	8,51	4,45	11,8	3,9	17,0	0,50	12,0	0,48
717 RF		210 B	31,75	1 ¼	9,65	13,28	13,41	10,16	5,08	14,7	4,1	19,6	0,67	14,5	0,55
722 RF		212 B	38,10	1 ½	11,68	15,62	15,75	12,07	5,72	16,1	4,6	22,7	0,89	18,5	0,80
728 RF		216 B	50,80	2	17,02	25,40	25,60	15,88	8,28	21,0	5,4	36,1	2,10	40,0	1,74

For details on orders and enquiries see page 148. Sprockets on request.
Information on the selection of chain sizes and drives as of page 136.

Connecting links: According to ISO (...)



No. 4 (B)
Inner link

No. 7 (A)
Outer link
(to be riveted)

No. 111 (S)
Connecting link
with cottered pin

No. 11 (E)
for chain No.
713 with spring
clip (E)

No. 12 (L)
Single
cranked link

Type 1

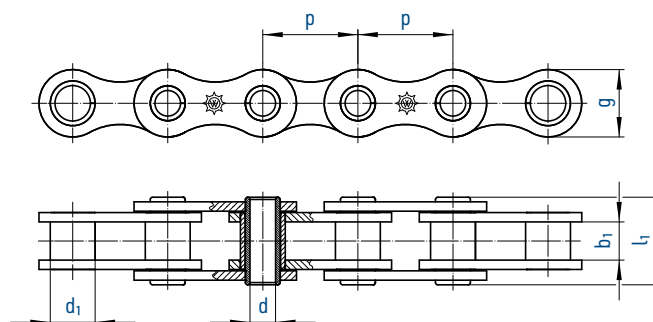

Type 2

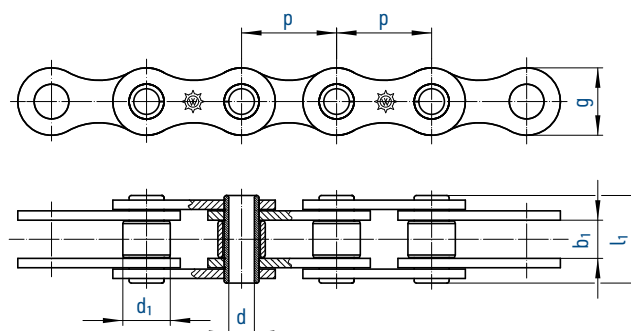

Type 3

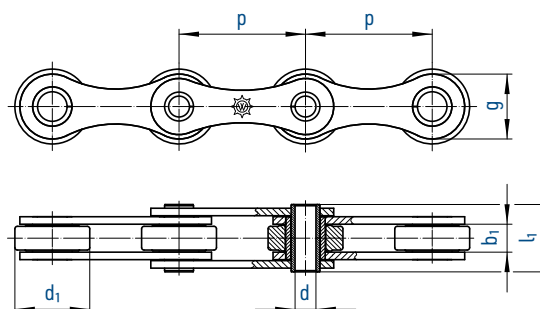

Chain		Pitch		Inner width	Roller (Bushing) Ø	Hollow pin		Plate height	Type	Bearing area	Breaking load	Weight
⚙️		p		b ₁	d ₁	Bore Ø	Width	g		f	F _B	q
No.	Ind.	mm	inch	min.	max.	min.	l ₁	max.		cm ²	kN	kg/m
01105		12,700	1/2	3,30	7,75	4,2	10,2	10,5	2	0,14	10,0	0,34
01462		12,700	1/2	7,75	8,51	4,0	17,0	12,2	1	0,68	10,0	0,65
01463		12,700	1/2	9,50	8,51	4,0	19,0	11,8	2	0,20	14,0	0,68
01500		15,875	5/8	6,50	10,16	5,0	17,0	14,7	2	0,28	15,0	0,74
01501		15,875	5/8	9,50	10,16	5,0	20,0	14,7	2	0,28	15,0	0,83
01513		19,050	3/4	11,70	12,07	5,0	22,5	16,1	2	0,30	25,0	1,07
01589		38,100	1 1/2	15,20	18,00	10,2	34,5	28,0	1	2,28	45,0	2,62
01598	^{1,3}	50,000	-	15,00	26,00	14,4	35,6	40,0	1	4,20	100,0	4,10
01650	^{4,5}	50,800	2	11,00	30,00	8,2	27,0	26,0	3	1,94	50,0	2,15
01650RF	^{4,5,6}	50,800	2	11,00	30,00	8,2	27,0	26,0	3	1,94	32,0	2,15

Electrogalvanised or nickel-plated chains on request. In this case chains may only have 80 % of the tensile strength.

¹ with straight side plates ³ also supplied with small rollers 32 mm Ø (Type 3) ⁴ also with plastic rollers ⁵ support rollers

⁶ made of stainless and acid resistant steel W.-No. 1.4301

For details on orders and enquiries see page 148. Sprockets on request.

Information on the selection of chain sizes and drives as of page 136.

Hollow pin chains are to be connected by means of outer links (pin links). For the chains No. 01597 and No. 01598 straight connecting links with Seeger circlip ring can be supplied.



Type A bent attachments, one side

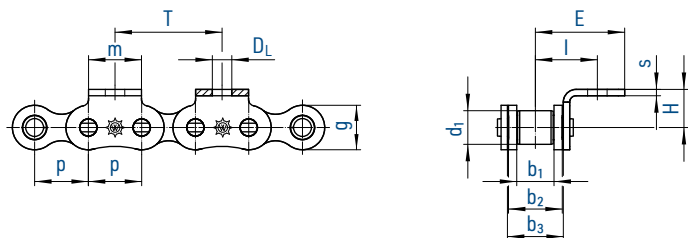

Type B bent attachments, both sides

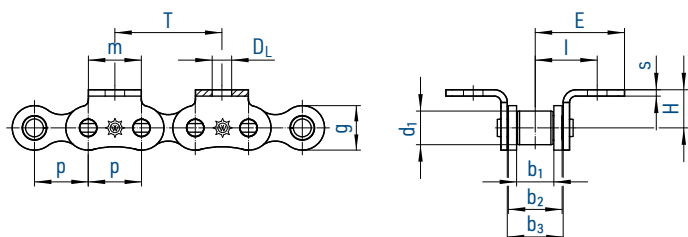

Type C bent over chain attachments, one side

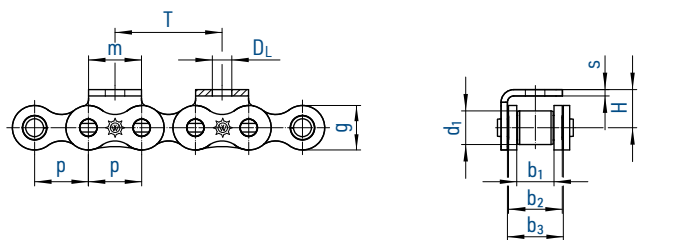

Basic chain		Pitch		Inner width	Inner link width	Outer plate width	Roller Ø	Plate height	Attachment dimensions					
No.	Ind.	p		b ₁ min.	b ₂ max.	b ₃ min.	d ₁ max.	g max.	m	D _L	I	F	H	s
		mm	inch	mm	mm	mm	mm	mm	mm	mm	mm	mm	mm	mm
450		8,000	-	3,00	4,77	4,90	5,00	7,1	8,0	3,2	6,6	12,0	5,0	0,80
455	^{1,15}	9,525	³ / ₈	5,72	8,53	8,66	6,35	8,2	8,0	3,5	9,5	13,5	6,5	1,25
331	¹⁷	12,700	¹ / ₂	3,30	5,80	5,93	7,75	9,9	10,5	3,5	9,0	15,1	7,0	0,95
332	¹⁷	12,700	¹ / ₂	4,88	7,20	7,33	7,75	9,9	10,5	3,5	9,7	15,8	7,0	0,95
462	¹⁵	12,700	¹ / ₂	7,75	11,30	11,43	8,51	11,8	12,5	4,5	13,1	19,0	10,0	1,50
501	¹⁵	15,875	⁵ / ₈	9,65	13,28	13,41	10,16	14,7	15,0	5,5	16,7	26,5	10,0	1,70
513	¹⁵	19,050	³ / ₄	11,68	15,62	15,75	12,07	16,1	18,5	6,6	18,6	29,0	11,0	1,80
548	^{15,16}	25,400	1	17,02	25,40	25,60	15,88	21,0	25,0	9,0	28,9	41,8	18,0	3,00
563		31,750	1 ¹ / ₄	19,56	29,00	29,20	19,05	26,4	35,0	9,0	33,4	49,0	18,0	3,75
596		38,100	1 ¹ / ₂	25,40	37,90	38,20	25,40	33,4	38,0	11,0	43,6	62,6	25,0	5,00
613		44,450	1 ³ / ₄	30,99	46,50	46,80	27,94	37,0	45,0	14,0	54,1	78,0	32,0	6,00
652		50,800	2	30,99	45,50	45,80	29,21	42,2	50,0	14,0	53,6	75,4	35,0	6,00
40	¹⁵	12,700	¹ / ₂	7,85	11,17	11,23	7,92	12,0	10,5	3,5	12,7	17,9	7,9	1,50
50	¹⁵	15,875	⁵ / ₈	9,40	13,84	13,90	10,16	15,1	12,7	5,2	15,9	23,9	10,3	2,00
60	¹⁵	19,050	³ / ₄	12,57	17,75	17,81	11,91	18,1	15,9	5,2	19,1	28,2	11,9	2,40
80	¹⁵	25,400	1	15,75	22,60	22,66	15,88	24,1	19,1	6,7	25,4	37,3	15,9	3,20

¹ with straight side plates ¹⁵ also with single hole bent attachments on inner link ¹⁶ on inner link s = 4 ¹⁷ can also be supplied with m = 16

All designs can also be supplied as MARATHON roller chains (maintenance-free), BIATHLON, BIATHLON KS, TRIATHLON and TRIATHLON KS! For details on orders and enquiries see page 149. For untoleranced dimensions DIN ISO 2768 c applies.



Type D straight attachments, one side

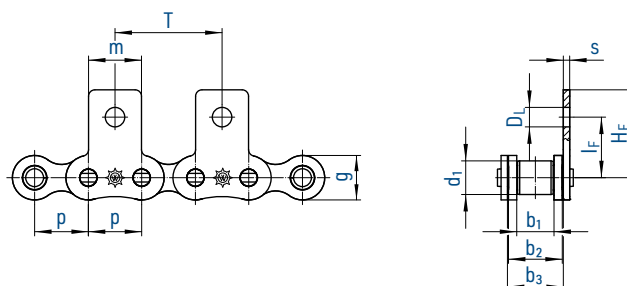

Type E straight attachments, both sides

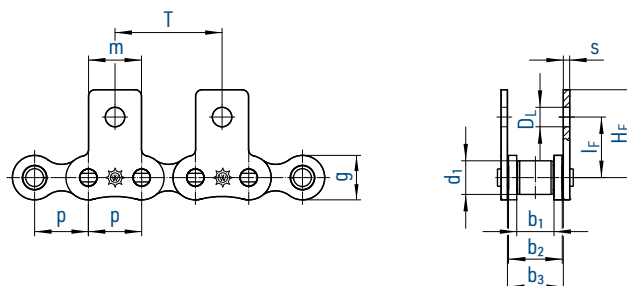

Type F extended pins (available on alternate sides)

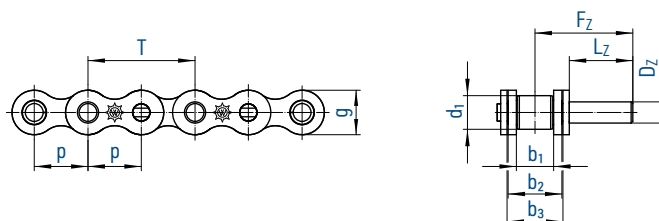

Basic chain		Pitch		Inner width	Inner link width	Outer plate width	Roller Ø	Plate height	Attachment dimensions							
⚙		p		b ₁ min.	b ₂ max.	b ₃ min.	d ₁ max.	g max.	m	D _L	I _F	H _F	s	D _Z ¹⁹ h9	L _Z ¹⁹	F _Z ¹⁹
No.	Ind.	mm	inch	mm	mm	mm	mm	mm	mm	mm	mm	mm	mm	mm	mm	mm
450		8,000	-	3,00	4,77	4,90	5,00	7,1	8,0	3,2	7,5	13,00	0,80	4,0	10,0	13,3
455	^{1,18}	9,525	3/8	5,72	8,53	8,66	6,35	8,2	8,0	3,5	9,3	13,30	1,25	5,0	15,0	20,7
331	¹⁷	12,700	1/2	3,30	5,80	5,93	7,75	9,9	10,5	3,5	11,3	17,55	0,95	5,0	15,0	19,0
332	¹⁷	12,700	1/2	4,88	7,20	7,33	7,75	9,9	10,5	3,5	11,3	17,55	0,95	5,0	15,0	19,7
462	¹⁸	12,700	1/2	7,75	11,30	11,43	8,51	11,8	12,5	4,5	14,7	20,30	1,50	6,0	15,0	22,4
501	¹⁸	15,875	5/8	9,65	13,28	13,41	10,16	14,7	15,0	5,5	17,2	26,70	1,70	6,5	20,0	28,5
513	¹⁸	19,050	3/4	11,68	15,62	15,75	12,07	16,1	18,5	6,6	18,3	28,60	1,80	7,0	20,0	29,8
548	^{16,18}	25,400	1	17,02	25,40	25,60	15,88	21,0	25,0	9,0	28,6	41,50	3,00	10,0	30,0	45,9
563		31,750	1 1/4	19,56	29,00	29,20	19,05	26,4	35,0	9,0	30,5	46,00	3,75	12,0	30,0	48,4
596		38,100	1 1/2	25,40	37,90	38,20	25,40	33,4	38,0	11,0	41,0	60,00	5,00	16,0	35,0	59,1
613		44,450	1 3/4	30,99	46,50	46,80	27,94	37,0	45,0	14,0	52,5	75,50	6,00	20,0	40,0	69,0
652		50,800	2	30,99	45,50	45,80	29,21	42,2	50,0	14,0	53,5	76,10	6,00	20,0	40,0	69,0
40		12,700	1/2	7,85	11,17	11,23	7,92	12,0	10,5	3,5	11,5	17,65	1,50	5,0	15,0	22,2
50		15,875	5/8	9,40	13,84	13,90	10,16	15,1	12,7	5,2	15,9	23,50	2,00	5,08	11,9	21,1
60		19,050	3/4	12,57	17,75	17,81	11,91	18,1	15,9	5,2	18,3	27,20	2,40	5,94	14,3	25,8
80		25,400	1	15,75	22,60	22,66	15,88	24,1	19,1	6,7	24,6	35,50	3,20	7,92	19,1	33,7

¹ with straight side plates ¹⁶ on inner link s = 4 ¹⁷ can also be supplied with m = 16 ¹⁸ also with straight attachments on inner link

¹⁹ other dimensions available on request

All designs can also be supplied as MARATHON roller chains (maintenance-free), BIATHLON, BIATHLON KS, TRIATHLON and TRIATHLON KS!
For details on orders and enquiries see page 149. For untoleranced dimensions DIN ISO 2768 c applies.



Type A2 bent attachments, one side

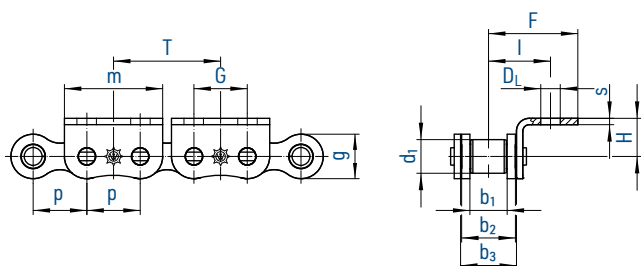

Type B2 bent attachments, both sides

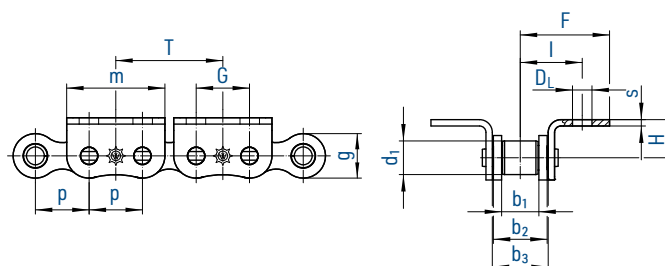

Type D2 straight attachments, one side

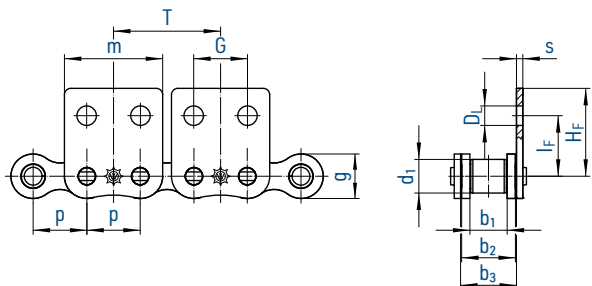

Type E2 straight attachments, both sides

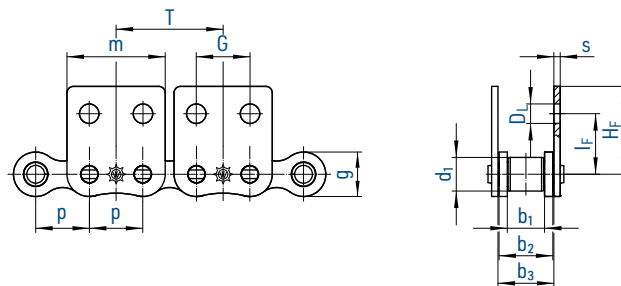

Basic chain		Pitch		Inner width	Inner link width	Outer plate width	Roller Ø	Plate height	Attachment dimensions								
⚙		p		b ₁ min.	b ₂ max.	b ₃ min.	d ₁ max.	g max.	m	D _L	G	I	F	H	l _F	H _F	s
No.	Ind.	mm	inch	mm	mm	mm	mm	mm	mm	mm	mm	mm	mm	mm	mm	mm	mm
455	^{1,20}	9,525	3/8	5,72	8,53	8,66	6,35	8,2	18,2	3,2	9,5	9,8	13,5	5,7	9,2	12,6	1,25
462		12,700	1/2	7,75	11,30	11,43	8,51	11,8	24,4	4,5	12,7	13,1	19,0	10,0	14,7	20,3	1,50
501		15,875	5/8	9,65	13,28	13,41	10,16	14,7	30,3	5,5	15,9	16,7	26,5	10,0	17,2	26,7	1,70
513		19,050	3/4	11,68	15,62	15,75	12,07	16,1	34,8	6,6	19,1	18,6	29,0	11,0	18,7	28,6	1,80
548		25,400	1	17,02	25,40	25,60	15,88	21,0	46,5	9,0	25,4	28,9	41,8	18,0	28,6	41,5	3,00
563		31,750	1 1/4	19,56	29,00	29,20	19,05	26,4	55,8	9,0	31,8	33,4	49,4	18,0	30,5	46,0	3,75
596		38,100	1 1/2	25,40	37,90	38,10	25,40	33,4	71,1	11,0	38,1	43,6	62,6	25,0	41,0	60,0	5,00

Roller chains (stainless steel) with two-hole bent and straight attachments

455 RF	^{1,20}	9,525	3/8	5,72	8,53	8,66	6,35	8,2	18,2	3,2	9,5	9,8	13,2	5,7	9,2	12,6	1,25
462 RF		12,700	1/2	7,75	11,30	11,43	8,51	11,8	24,4	4,5	12,7	13,1	19,0	10,0	14,7	20,3	1,60
501 RF		15,875	5/8	9,65	13,28	13,41	10,16	14,7	30,3	5,5	15,9	16,7	26,5	10,0	17,2	26,7	1,70
513 RF		19,050	3/4	11,68	15,62	15,75	12,07	16,1	34,8	6,6	19,1	18,5	29,0	11,0	18,7	28,6	1,80
548 RF		25,400	1	17,02	25,40	25,60	15,88	21,0	46,5	10,0	25,4	28,9	41,8	18,0	28,6	41,5	3,00

¹ with straight side plates ²⁰ can be supplied with or without bore

All designs can also be supplied as MARATHON roller chains (maintenance-free), BIATHLON, BIATHLON KS, TRIATHLON and TRIATHLON KS! Sprockets made of stainless steel or plastic are available on request.

For details on orders and enquiries see page 149. For untoleranced dimensions DIN ISO 2768 c applies.



Type A bent attachments, one side

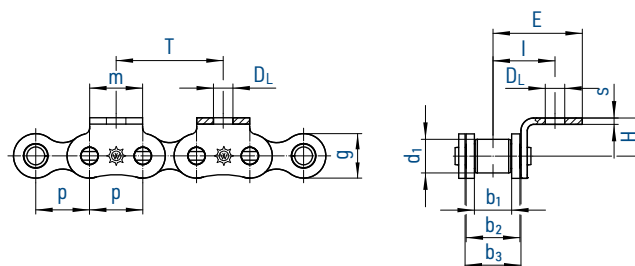

Type B bent attachments, both sides

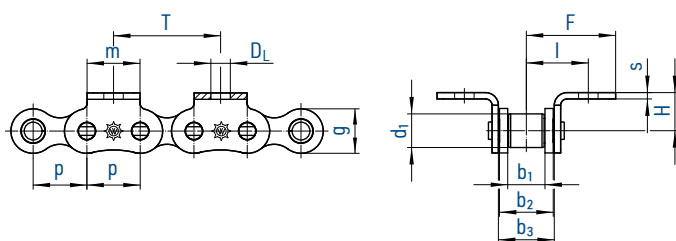

Type D straight attachments, one side

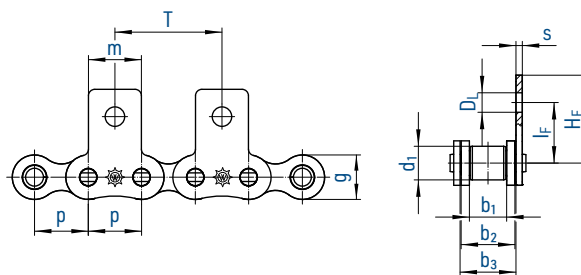

Type E straight attachments, both sides

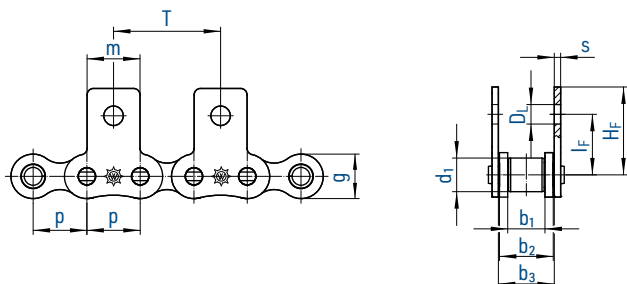

Type F extended pins (available on alternate sides)

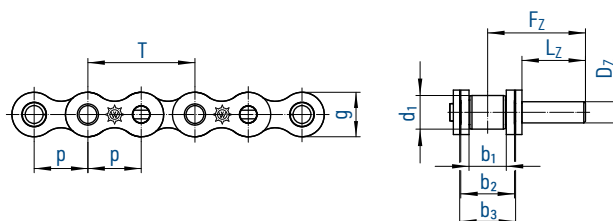

Basic chain		Pitch	Inner width	Inner link width	Outer plate width	Roller Ø	Plate height	Attachment dimensions											
								p	b ₁ min.	b ₂ max.	b ₃ min.	d ₁ max.	g max.	m	DL	I	F	H	I _F
No.	Ind.	mm	mm	mm	mm	mm	mm	mm	mm	mm	mm	mm	mm	mm	mm	mm	mm	mm	mm
450 RF		8,000	3,00	4,77	4,90	5,00	7,1	8,0	3,2	6,6	12,0	5,0	7,5	13,0	0,80	4,0	10	13,3	
455 RF	^{1,21}	9,525	5,72	8,53	8,66	6,35	8,2	8,0	3,5	9,5	13,5	6,5	9,3	13,3	1,25	5,0	15	20,7	
331 RF	¹⁷	12,700	3,30	5,80	5,93	7,75	9,9	10,5	3,5	9,0	15,1	7,0	11,3	17,6	0,95	5,0	15	19,0	
40 RF	²¹	12,700	7,85	11,15	11,28	7,95	12,0	10,5	3,5	11,8	17,9	7,9	11,5	17,7	1,50	5,0	15	22,2	
332 RF	¹⁷	12,700	4,88	7,20	7,33	7,75	9,9	10,5	3,5	9,7	15,8	7,0	11,5	17,6	0,95	5,0	15	19,7	
462 RF	²¹	12,700	7,75	11,30	11,43	8,51	11,8	12,5	4,5	13,1	19,0	10,0	14,7	20,3	1,60	6,0	15	22,4	
501 RF	²¹	15,875	9,65	13,28	13,41	10,16	14,7	15,0	5,5	16,7	27,0	10,0	17,2	26,7	1,70	6,5	20	28,5	
513 RF	²¹	19,050	11,68	15,62	15,75	12,07	16,1	18,5	6,6	18,5	29,0	11,0	18,3	28,6	1,80	7,0	20	29,8	
548 RF	^{16,21}	25,400	17,02	25,40	25,60	15,88	21,0	25,0	10,0	28,9	41,8	18,0	28,6	41,5	3,00	10,0	30	45,9	

¹ with straight side plates ¹⁶ on inner link s = 4 ¹⁷ can also be supplied with m = 16 ¹⁹ other dimensions available on request
²¹ also with single hole bent attachments on inner link

Sprockets made of stainless steel or plastic are available on request.

For details on orders and enquiries see page 149. For untoleranced dimensions DIN ISO 2768 c applies.



Type A G
bent attachments, one side

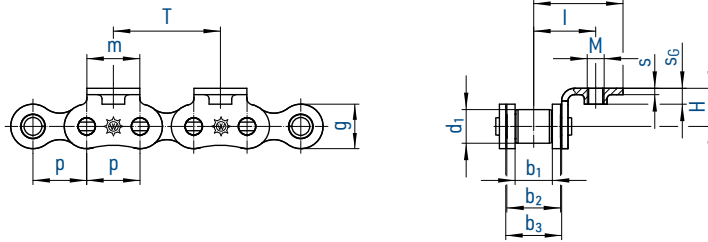

Type B G
bent attachments, both sides

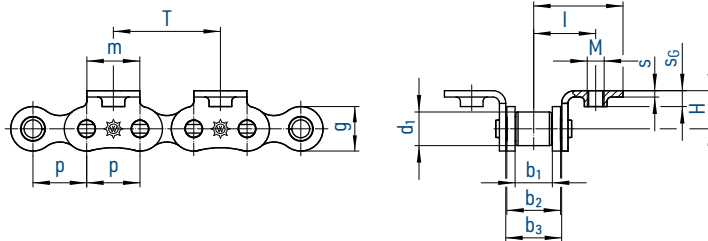

Type C G
bent over chain attachments, one side

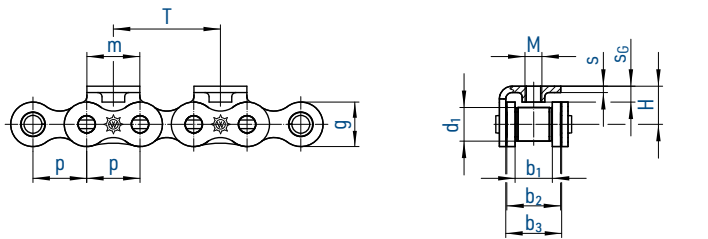

Type D G
straight attachments, one side

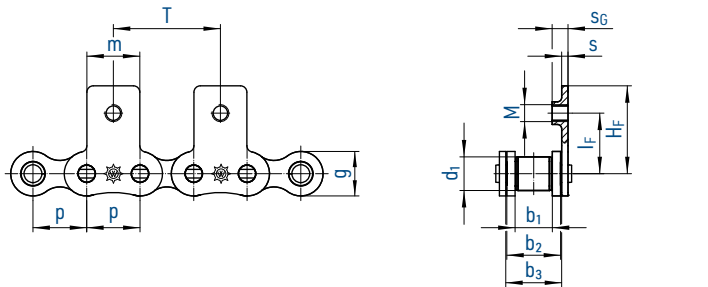

Type E G
straight attachments, both sides

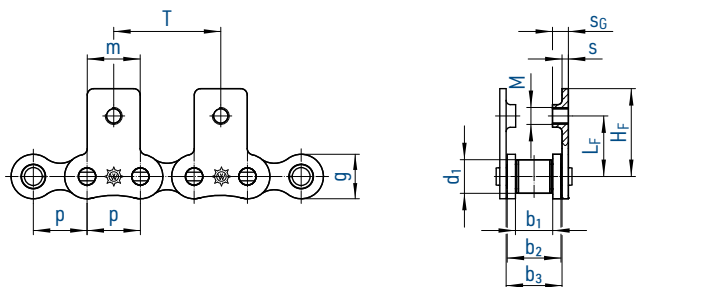

Basic chain		Pitch		Inner width	Inner link width	Outer plate width	Roller Ø	Plate height	Attachment dimensions								
		p		b ₁ min.	b ₂ max.	b ₃ min.	d ₁ max.	g max.	m	M Inside thread	l	F	H	IF	HF	s	S _G
No.	Ind.	mm	inch	mm	mm	mm	mm	mm	mm		mm	mm	mm	mm	mm	mm	mm
462	²²	12,700	1/2	7,75	11,30	11,43	8,51	11,8	12,5	M 4	13,1	19,0	10	14,7	20,3	1,5	4,0
501	²²	15,875	5/8	9,65	13,28	13,41	10,16	14,7	15,0	M 5	16,7	27,0	10	17,2	26,7	1,7	4,2
513	²²	19,050	3/4	11,68	15,62	15,75	12,07	16,1	18,5	M 6	18,5	29,0	11	18,3	28,6	1,8	4,5
548	²²	25,400	1	17,02	25,40	25,60	15,88	21,0	25,0	M 8	28,9	41,8	18	28,6	41,5	3,0	7,5

²² can also be supplied in stainless steel

All designs can also be supplied as MARATHON roller chains (maintenance-free), BIATHLON, BIATHLON KS, TRIATHLON and TRIATHLON KS!
For details on orders and enquiries see page 149. For untoleranced dimensions DIN ISO 2768 c applies.

Type A 2 G

bent attachments, one side

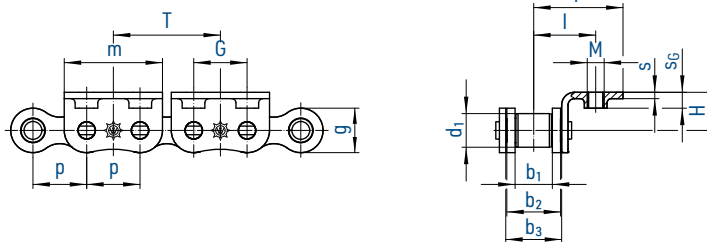

Type B 2 G

bent attachments, both sides

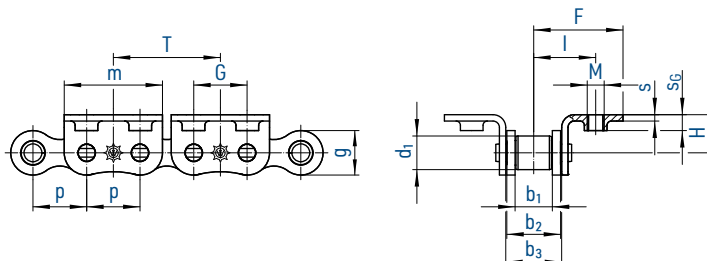

Type C 2 G

bent over chain attachments, one side

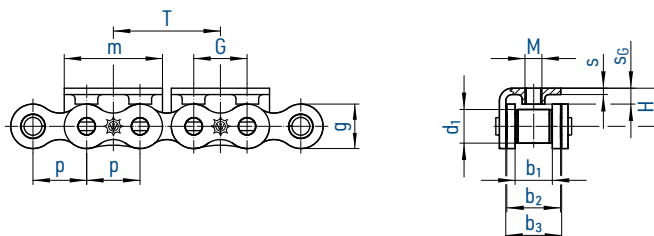

Type D 2 G

straight attachments, one side

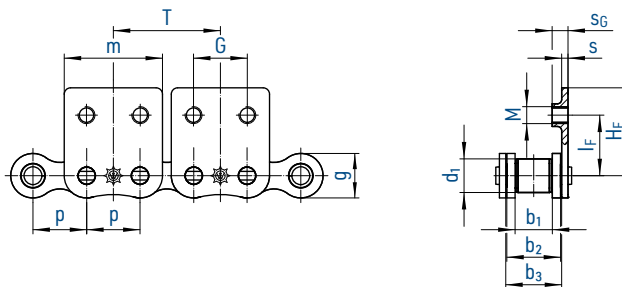

Type E 2 G

straight attachments, both sides

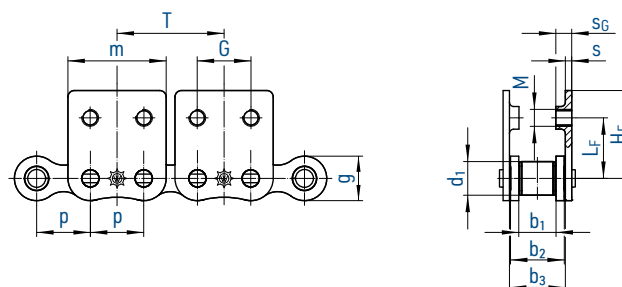

Basic chain		Pitch	Inner width	Inner link width	Outer plate width	Roller Ø	Plate height	Attachment dimensions									
No.	Ind.	p	b ₁ min.	b ₂ max.	b ₃ min.	d ₁ max.	g max.	m	M (Inside thread)	G	I	F	H	l _F	H _F	s	s _G
		mm	mm	mm	mm	mm	mm	mm	mm	mm	mm	mm	mm	mm	mm	mm	mm
462	²²	12,700	7,75	11,30	11,43	8,51	11,8	24,4	M 4	12,7	13,1	19,0	10	14,7	20,3	1,5	4,0
501	²²	15,875	9,65	13,28	13,41	10,16	14,7	30,3	M 5	15,9	16,7	27,0	10	17,2	26,7	1,7	4,2
513	²²	19,050	11,68	15,62	15,75	12,07	16,1	34,8	M 6	19,1	18,5	29,0	11	18,3	28,6	1,8	4,5
548	²²	25,400	17,02	25,40	25,60	15,88	21,0	46,5	M 8	25,4	28,9	41,8	18	28,6	41,5	3,0	7,5

²² can also be supplied in stainless steel

All designs can also be supplied as MARATHON roller chains (maintenance-free), BIATHLON, BIATHLON KS, TRIATHLON and TRIATHLON KS! For details on orders and enquiries see page 149. For untoleranced dimensions DIN ISO 2768 c applies.



Type A
bent attachments, one side

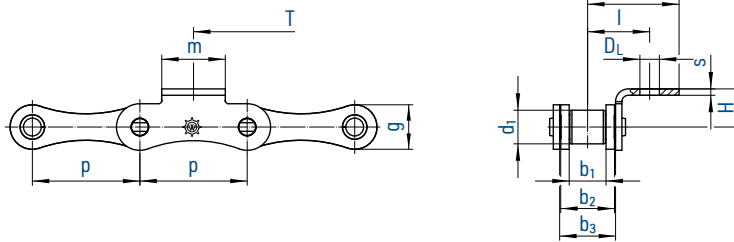

Type B
bent attachments, both sides

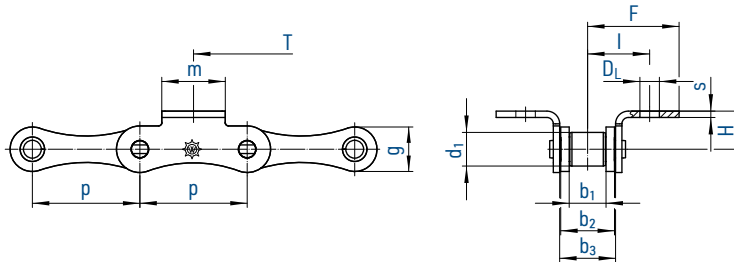

Type C
bent over chain attachments, one side

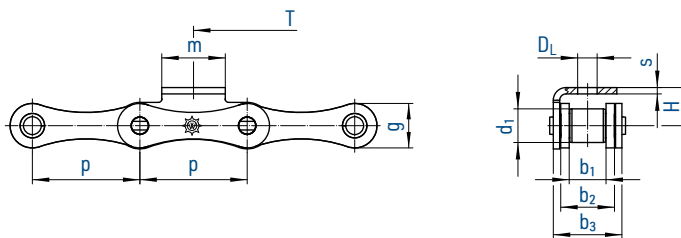

Basic chain		Pitch		Inner width	Inner link width	Outer plate width	Roller Ø	Plate height	Attachment dimensions					
⚙️		p		b ₁ min.	b ₂ max.	b ₃ min.	d ₁ max.	g max.	m	D _L	l	F	H	s
No.	Ind.	mm	inch	mm	mm	mm	mm	mm	mm	mm	mm	mm	mm	mm
713		25,40	1	7,75	11,30	11,43	8,51	11,8	13,0	4,5	13,1	19,3	10,0	1,60
717		31,75	1 ¼	9,65	13,28	13,41	10,16	14,7	15,0	5,5	16,7	26,7	10,0	1,70
722		38,10	1 ½	11,68	15,62	15,75	12,07	16,1	19,0	6,6	18,5	26,0	11,0	1,80
728		50,80	2	17,02	25,45	25,58	15,88	21,0	30,0	9,0	28,9	43,0	18,0	3,00
734	*	63,50	2 ½	19,56	29,01	29,14	19,05	28,5	35,0	9,0	33,1	49,6	18,0	3,75

* g-measurement not according to standard

Double pitch stainless steel roller chains with single hole bent attachments

713 RF		25,40	1	7,75	11,30	11,43	8,51	11,8	13,0	4,5	13,1	19,5	10,0	1,60
717 RF		31,75	1 ¼	9,65	13,28	13,41	10,16	14,7	15,0	5,5	16,7	26,7	10,0	1,70
722 RF		38,10	1 ½	11,68	15,62	15,75	12,07	16,1	19,0	6,6	18,5	26,0	11,0	1,80
728 RF		50,80	2	17,02	25,45	25,58	15,88	21,0	30,0	9,0	28,9	43,0	18,0	3,00

All designs can also be supplied as MARATHON roller chains (maintenance-free)!
For details on orders and enquiries see page 149. For untoleranced dimensions DIN ISO 2768 c applies.

Type D
straight attachments, one side

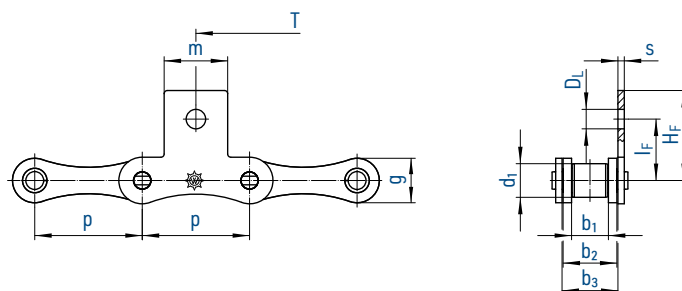

Type E
straight attachments, both sides

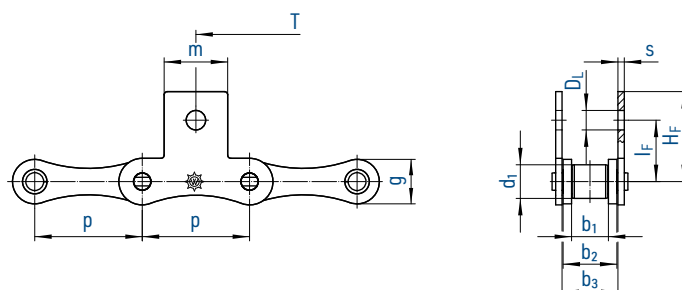

Type F
extended pin
(available on alternate sides)

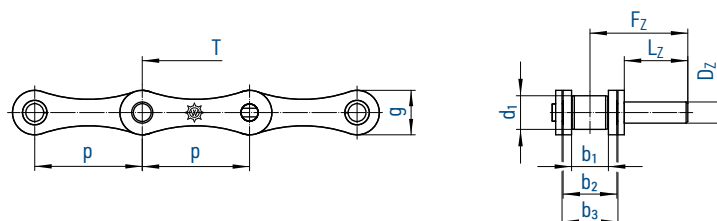

Basic chain		Pitch		Inner width	Inner link width		Outer plate width	Roller Ø	Plate height	Attachment dimensions							
										p	b ₁ min.	b ₂ max.	b ₃ min.	d ₁ max.	g max.	m	D _L
No.	Ind.	mm	inch	mm	mm	mm	mm	mm	mm	mm	mm	mm	mm	mm	mm	mm	mm
713		25,40	1	7,75	11,30	11,43	8,51	11,8	13,0	4,5	14,7	20,3	1,60	6,0	15,0	22,4	
717		31,75	1 ¼	9,65	13,28	13,41	10,16	14,7	15,0	5,5	17,0	26,7	1,70	6,5	20,0	28,5	
722		38,10	1 ½	11,68	15,62	15,75	12,07	16,1	19,0	6,6	17,6	26,0	1,80	7,0	20,0	29,8	
728		50,80	2	17,02	25,45	25,58	15,88	21,0	30,0	9,0	29,0	42,5	3,00	10,0	30,0	45,9	
734	*	63,50	2 ½	19,56	29,01	29,14	19,05	28,5	35,0	9,0	30,5	45,7	3,75	12,0	30,0	48,4	

* g-measurement not according to standard

Double pitch roller chains (stainless steel) with single hole straight attachments and extended pins

713 RF		25,40	1	7,75	11,30	11,43	8,51	11,8	13,0	4,5	14,7	20,3	1,60	6,0	15,0	22,4	
717 RF		31,75	1 ¼	9,65	13,28	13,41	10,16	14,7	15,0	5,5	17,0	26,7	1,70	6,5	20,0	28,5	
722 RF		38,10	1 ½	11,68	15,62	15,75	12,07	16,1	19,0	6,6	17,6	26,0	1,80	7,0	20,0	29,8	
728 RF		50,80	2	17,02	25,45	25,58	15,88	21,0	30,0	9,0	29,0	42,5	3,00	10,0	30,0	45,9	

¹⁹ can also be supplied in stainless steel

Can also be supplied as MARATHON roller chain (maintenance-free)!

For details on orders and enquiries see page 149. For untoleranced dimensions DIN ISO 2768 c applies.

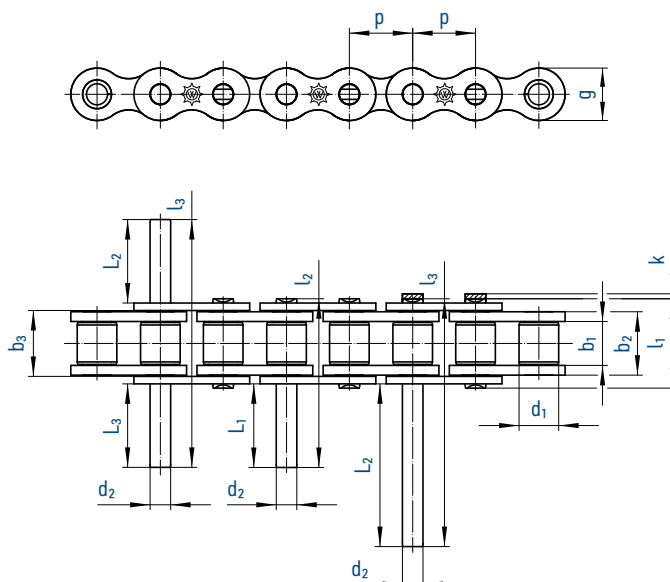

Basic chain		Pitch		Inner width	Inner link width	Outer plate width	Roller Ø	Pin Ø	Projection over connecting link	Plate height	Width over pin	Dimensions for extended pin				
		p		b ₁ min.	b ₂ max.	b ₃ min.	d ₁ max.	d ₂ max.	k max.	g max.	l ₁ max.	Overall length		Pin extension		
No.	Ind.	mm	inch	mm	mm	mm	mm	mm	mm	mm	mm	l ₂ ¹¹ max.	l ₃ ¹² max.	L ₁ max.	L ₂ max.	L ₃ max.
450		8,000	-	3,00	4,77	4,90	5,00	2,31	3,1	7,1	8,6	14,3	19,9	6,3	12,2	6,35
455	^{1,10}	9,525	3/8	5,72	8,53	8,66	6,35	3,28	3,3	8,2	13,5	23,1	33,7	11,0	21,6	11,15
462	¹⁰	12,700	1/2	7,75	11,30	11,43	8,51	4,45	3,9	11,8	17,0	30,7	44,9	15,3	29,5	15,30
501	¹⁰	15,875	5/8	9,65	13,28	13,41	10,16	5,08	4,1	14,7	19,6	36,2	52,8	18,2	34,8	18,00
513	¹⁰	19,050	3/4	11,68	15,62	15,75	12,07	5,72	4,6	16,1	22,7	41,8	61,3	21,0	40,5	20,90
548	¹⁰	25,400	1	17,02	25,40	25,60	15,88	8,28	5,4	21,0	36,0	67,5	99,3	33,6	65,4	33,70
552	¹⁰	30,000	-	17,02	25,40	25,60	15,88	8,28	5,4	21,0	36,0	67,5	99,3	33,6	65,4	33,70
563		31,750	1 1/4	19,56	29,00	29,20	19,05	10,19	6,1	26,4	41,5	79,7	116,1	38,6	75,3	38,70
577		35,000	-	19,60	27,00	27,20	19,05	10,19	6,1	26,0	38,3	79,7	116,1	41,8	78,5	41,80
596		38,100	1 1/2	25,40	37,90	38,10	25,40	14,63	6,6	33,4	53,0	101,8	150,2	50,5	98,7	50,50
613		44,450	1 3/4	30,99	46,60	46,70	27,94	15,90	7,4	37,0	63,6	124,7	184,3	61,7	121,7	62,00
652		50,800	2	30,99	45,60	45,70	29,21	17,81	7,9	42,3	63,6	126,0	184,5	62,2	121,2	62,10
35	¹⁰	9,525	3/8	4,68	7,47	7,52	5,08	3,59	3,3	9,1	13,2	22,0	32,5	11,0	21,5	11,10
40	¹⁰	12,700	1/2	7,85	11,15	11,28	7,95	3,96	3,9	12,0	17,8	30,1	45,2	14,8	29,9	15,35
50	¹⁰	15,875	5/8	9,40	13,80	13,93	10,16	5,08	4,1	15,0	20,5	38,7	56,8	19,4	37,5	19,40
60	¹⁰	19,050	3/4	12,57	17,70	17,85	11,91	5,94	4,6	18,0	25,4	48,3	71,1	24,2	47,0	24,20
80		25,400	1	15,75	22,50	22,70	15,88	7,92	5,4	24,1	33,5	62,6	92,0	31,3	60,6	31,30
100		31,750	1 1/4	18,90	27,40	27,60	19,05	9,53	6,1	30,1	40,4	76,3	112,2	38,2	74,1	38,20
120		38,100	1 1/2	25,22	35,30	35,60	22,23	11,10	6,6	36,2	50,3	96,1	141,9	48,2	94,0	48,20

¹ with straight side plates ¹⁰ can also be supplied in stainless steel ¹¹ Duplex pin ¹² Triplex pin

All designs can also be supplied as MARATHON roller chains (maintenance-free), BIATHLON, BIATHLON KS, TRIATHLON and TRIATHLON KS!
For details on orders and enquiries see page 149. For untoleranced dimensions DIN ISO 2768 c applies.



Simplex chain
with duplex connecting link

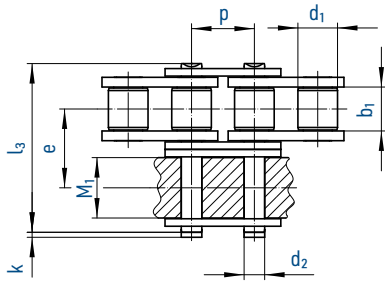

Simplex chain
with triplex connecting link

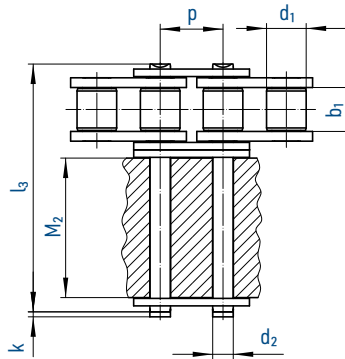

Simplex chain
with duplex connecting link

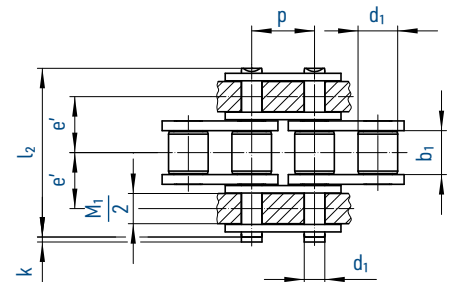

Duplex chain
with triplex connecting link

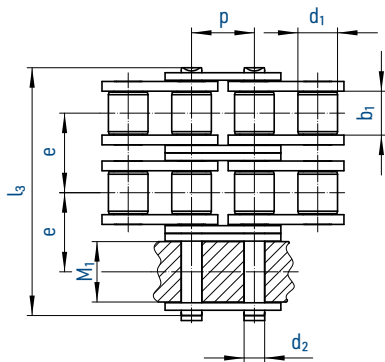

Duplex chain
with triplex connecting link

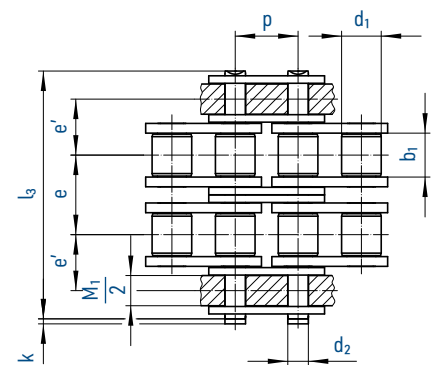

Chain		Pitch		Inner width	Roller Ø	Pin Ø	Transverse pitch		Attachment width		Projection over connecting link	Pin length	
No.	Ind.	mm	inch	b ₁ min.	d ₁ max.	d ₂ max.	e	e'	M ₁ max.	M ₂ max.		k max.	l ₂ max.
		455	¹⁰	9,525	3/8	5,72	6,35	3,28	10,24	7,24	8,5	-	3,3
D 455	¹⁰	9,525	3/8	5,72	6,35	3,28	10,24	7,24	8,5	-	3,3	-	34,0
462	¹⁰	12,700	1/2	7,75	8,51	4,45	13,92	10,10	11,3	25,6	3,9	31,0	-
D 462	¹⁰	12,700	1/2	7,75	8,51	4,45	13,92	10,10	11,3	-	3,9	-	44,9
501	¹⁰	15,875	5/8	9,65	10,16	5,08	16,59	11,62	13,3	30,0	4,1	36,2	-
D 501	¹⁰	15,875	5/8	9,65	10,16	5,08	16,59	11,62	13,3	-	4,1	-	52,8
513	¹⁰	19,050	3/4	11,68	12,07	5,72	19,46	13,63	15,6	34,8	4,6	42,2	-
D 513	¹⁰	19,050	3/4	11,68	12,07	5,72	19,46	13,63	15,6	-	4,6	-	61,7
548	¹⁰	25,400	1	17,02	15,88	8,28	31,88	22,30	25,4	56,8	5,4	68,0	-
D 548	¹⁰	25,400	1	17,02	15,88	8,28	31,88	22,30	25,4	-	5,4	-	99,9

¹⁰ can also be supplied in stainless steel

All designs can also be supplied as MARATHON roller chains (maintenance-free), BIATHLON, BIATHLON KS, TRIATHLON and TRIATHLON KS! For details on orders and enquiries see page 149. For untoleranced dimensions DIN ISO 2768 c applies.

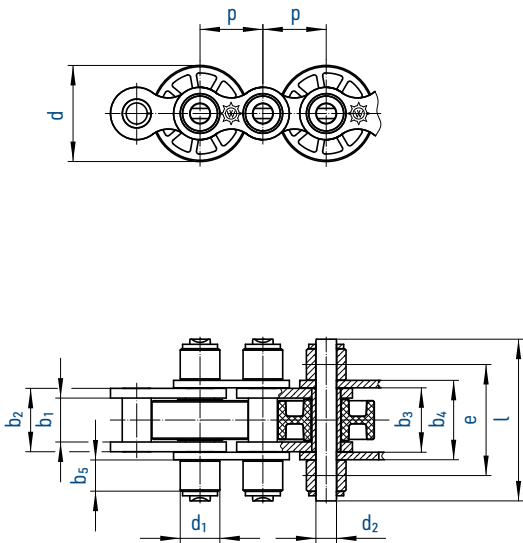
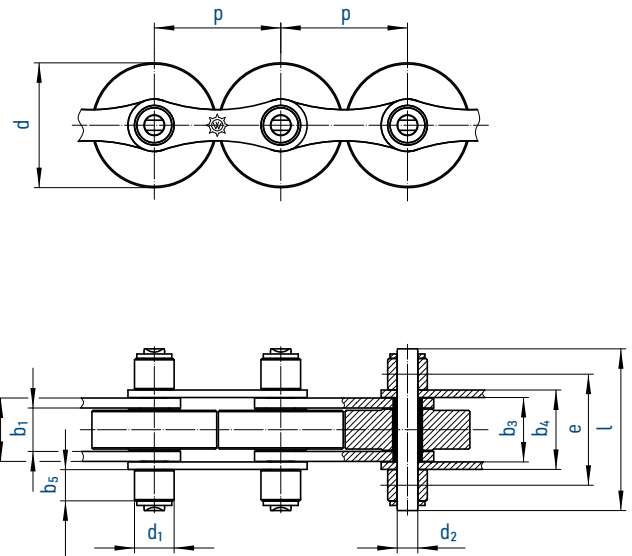
Design E

Double pitch roller chain Design L

Chain		Pitch	Design	Inner width	Inner link width	Width between over outer plates		Support roller Ø	Pin Ø	Transverse pitch	Plate height	Width over pin	Support roller width	Width over pin type I	Support roller width
		p		b ₁ min.	b ₂ max.	b ₃ min.	b ₄ max.	d ₁	d ₂ max.	e	g max.	l max.	b ₅ max.	l max.	b ₅ max.
No.	Ind.	mm		mm	mm	mm	mm	mm	mm	mm	mm	mm	mm	mm	mm
513 SF		19,050	E	11,68	15,62	15,80	20,0	12,00	5,72	31,50	16,1	48,0	11,5	43,0	9,0
548 SF		25,400	E	17,02	25,45	25,81	32,0	15,88	8,28	44,50	21,0	65,0	12,5	-	-
722 SF		38,100	L	11,68	15,62	15,80	20,0	12,00	5,72	31,50	16,1	48,0	11,5	-	-
728 SF		50,800	L	17,02	25,45	25,81	32,0	15,88	8,28	44,50	21,0	65,0	12,5	-	-
D 513 SF		19,050	D	11,68	15,62	15,80	20,0	12,07	5,72	52,00	16,1	68,0	11,5	-	-
D 548 SF		25,400	D	17,02	25,45	25,81	32,0	15,88	8,28	76,76	21,0	97,0	12,5	-	-
T 455 SF	²⁷	9,525	T	5,72	8,53	-	-	6,35	3,28	20,48	8,2	34,0	-	-	-
T 513 SF		19,050	T	11,68	15,62	15,80	20,0	12,07	5,72	38,92	16,1	61,7	-	-	-
T 548 SF		25,400	T	17,02	25,45	25,81	32,0	15,88	8,28	63,76	21,0	99,9	-	-	-

Accumulator chains (stainless steel)

513 SF RF		19,050	E	11,68	15,62	15,80	20,0	12,00	5,72	31,50	16,1	48,0	11,5	43,0	9,0
548 SF RF		25,400	E	17,02	25,45	25,81	32,0	15,88	8,28	44,50	21,0	65,0	12,5	-	-
722 SF RF		38,100	L	11,68	15,62	15,80	20,0	12,00	5,72	31,50	16,1	48,0	11,5	-	-
728 SF RF		50,800	L	17,02	25,45	25,81	32,0	15,88	8,28	44,50	21,0	65,0	12,5	-	-
T 513 SF RF		19,050	T	11,68	15,62	-	-	12,07	5,72	38,92	16,1	61,7	-	-	-
T 548 SF RF		25,400	T	17,02	25,45	-	-	15,88	8,28	63,76	21,0	99,9	-	-	-

²⁷ Different from the drawing: No inner links in the middle strand! Roller width: 8,5 mm.

Sprockets are available for all accumulator chains!

Connecting links with securing circlips.

Our connecting links always have the same length l as the ordinary pins.

Temperature range: - 30 to 100°C for steel conveyor rollers

- 10 to 60°C for plastic conveyor rollers

Design D

Design T

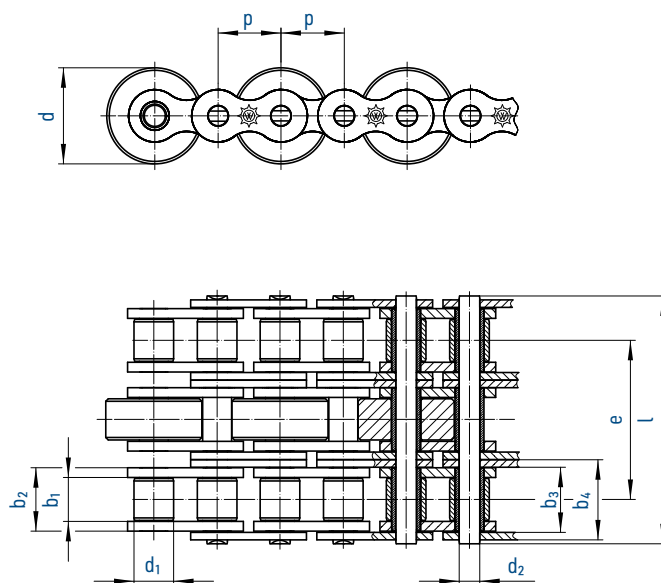
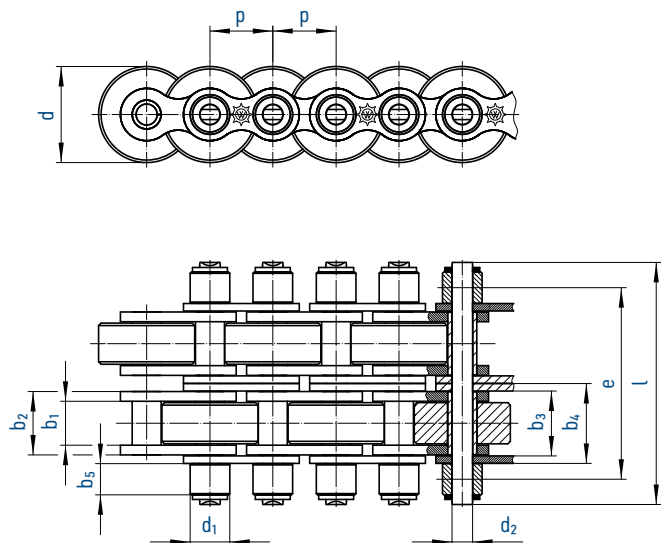

Width over pin type II l max. mm.	Support roller width b ₅ max. mm	Conveyor rollers						Breaking load F _B min. kN	Maximum load per m conveyor chain with 10 m conveyor length	
		Designation for material			Diameter				Steel	Plastic
		Steel	PA 6.6	Vestamide	d	type I d	type II d			
40,0	7,5	SF	SFK	SFV	24,0	26,0	28,0	29,00	300	260
-	-	SF	SFK	SFV	38,5	-	-	60,00	600	500
-	-	SF	SFK	SFV	24,0	26,0	28,0	29,00	300	260
-	-	SF	SFK	SFV	38,5	40,0	50,0	60,00	600	500
-	-	SF	SFK	SFV	24,0	26,0	28,0	57,80	600	520
-	-	SF	SFK	SFV	38,5	-	-	120,00	1200	1000
-	-	SF	SFK	SFV	9,2	15,0	-	16,80	100	100
-	-	SF	SFK	SFV	24,0	26,0	28,0	60,00	600	260
-	-	SF	SFK	SFV	38,5	-	-	120,00	1200	500

Accumulator chains (stainless steel)

40,0	7,5	SF RF	SFK RF	SFV RF	24,0	26,0	28,0	18,50	200	200
-	-	SF RF	SFK RF	SFV RF	38,5	-	-	40,00	300	300
-	-	SF RF	SFK RF	SFV RF	24,0	26,0	28,0	18,50	200	200
-	-	SF RF	SFK RF	SFV RF	38,5	40,0	50,0	40,00	300	300
-	-	SF RF	SFK RF	SFV RF	24,0	26,0	28,0	31,45	400	400
-	-	SF RF	SFK RF	SFV RF	38,5	-	-	68,00	600	600

The load per m applies for 10 m conveyor distance per double chain strand. The load may be proportionally increased for shorter chain strands and must be proportionally decreased for longer conveyor distances: e.g. 5 m conveyor distance = double load, 20 m conveyor distance = half load.

Maximum conveyor distances 25 - 30 m. The installation of guide plates is recommended as of 15 m (see page 74).

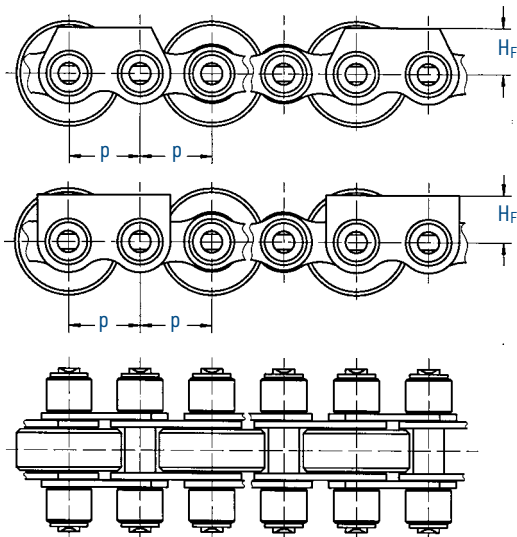

513 SF
548 SF

The guide plate distance is an even multiple of the pitch, e.g. $T = 4p$

Chain	p	H_F	
No.	mm	mm	mm
513 SF	19,05	10,7	$\pm 0,1$
548 SF	25,40	18,0	$\pm 0,1$

Design with guide plates

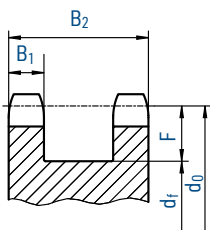
Axial profile of sprockets for accumulator chains



$$d_f = d_0 - 2F$$

Chain	B_1	B_2	F
No.	mm	mm	mm
T 455	5,2	25,7	8,0
513 SF	10,6	42,0	16,0
D 513 SF	10,6	62,6	16,0
T 513 SF	10,8	88,6	16,0
548 SF	12,0	56,5	22,0
D 548 SF	12,0	88,8	22,0
T 548 SF	15,8	79,6	22,0
722 SF	10,6	42,0	16,0
728 SF	12,0	56,6	27,0

Sprockets are available for all accumulator chains.

Chain guide for accumulator chains

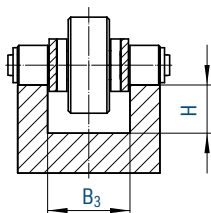

Chain	B_3	H
No.	mm	mm
513 SF	20,8	15,0
513 SFK	20,8	15,0
D 513 SF	40,5	15,0
548 SF	33,0	20,0
D 548 SF	66,0	20,0
722 SF	20,8	15,0
728 SF	33,0	27,0

Different designs, roller diameters and pin lengths are available on request

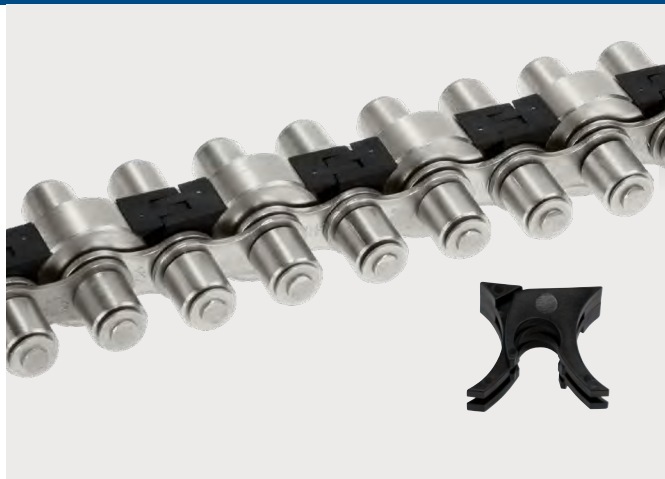

Accumulator chain with AFS-Clip

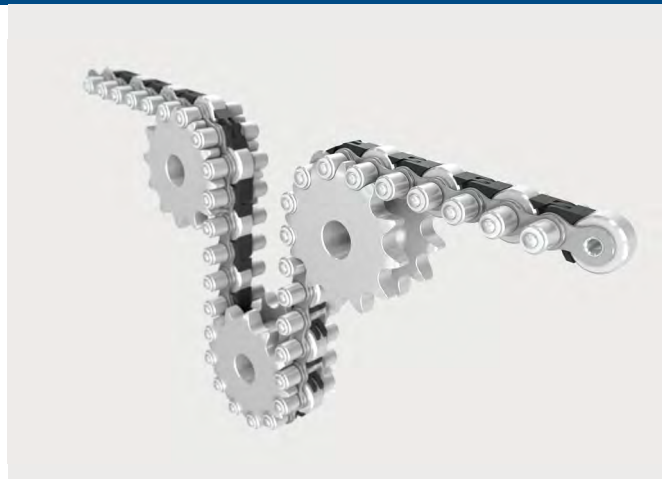

Omega drive

Accumulator chain AFS – optimal equipment and finger protection

- Prevents small parts from entering into gaps between conveyor rollers
- Increases operational safety
- Covers danger zone in chain deflection range as well
- Both-way deflections (e.g. with omega drives) still possible
- Can be supplied with different diameters and in various materials

Accumulator chains have a so-called conveyor roller on every other pitch. This is required for the transport of the material to be conveyed and ensures the smoothly running of the chain under the goods during accumulation without damaging them.

The chain link joint between the conveyor rollers constitutes a larger gap into which small parts might enter and then damage the chain or the entire system. Depending on the respective application area,

there is also the danger of fingers reaching into these gaps and thus causing injuries.

An accumulator chain with AFS clip ensures a trouble-free operation of conveyance and assembly systems and contributes considerably to operational safety according to effective machinery directives. For due to the flat design of the AFS clip the gap between the conveyor rollers is completely closed. The two-piece clip is mounted by snapping it onto the chain bushing of the inner link also covering the danger zone in the deflection range of the chain. Therefore both-way deflections, e.g. with omega drives, are still possible.

Depending on the respective application, conveyor rollers with different diameters made of various materials (steel, PA 6.6, PA 12 antistatic) can be supplied.

Accumulator chains can also be supplied in stainless steel, as maintenance-free MARATHON chains as well as in duplex or triplex designs.

AFS-Clips – Retrofitting for safety

For standard accumulator chains with conveyor roller diameters of 24 mm and 26 mm



The two-piece clip is mounted by simply snapping it onto the chain bushing of the inner link.

Due to the flat design of the AFS clip the construction-related gap between the conveyor rollers is completely closed. Hence equipment and finger protection is considerably increased.

Retrofitting of this innovative and easily mountable protective safety feature is possible for every standard accumulator chain with conveyor roller diameters of 24 mm and 26 mm. The two-piece clip is mounted by simply snapping it onto the chain bushing of the inner link. No tools are necessary since the pieces can easily be snapped directly onto the chain from the top. The correct position is guaran-

teed by a clear locking in place of the clip during mounting. Owing to its innovative hinge system it also covers the danger zone in the deflection range of the chain. Therefore both-way deflections, e.g. for omega drives, are possible.

Thus the wear-resistant AFS clips ensure a trouble-free operation of conveyance and assembly systems and contribute considerably to operational safety according to effective machinery directives.



ATC chains

High storage capacity in the tightest of spaces

WIPPERMANN ATC chains have been developed as tool storage and organizing devices for NC/CNC machining centres as well as for storage chains used to construct e.g. reamers or milling tools. The chains are manufactured individually to customers' requirements. The two standard types No. 320 and No. 340 are the basic chains, which can be customised for most applications with tool holding attachments such as SK, HSK and Capto®*.

For small tool attachment systems and other applications ATC chains can be individually developed based on standard roller chains or on a combination of roller chains and double pitch chains respectively.

The chains are designed for holding tools and are used when constructions with e.g. discs are insufficient. Depending on the respective construction (e.g. in case of a meander-shaped design) the chain has a storage capacity of more than 100 tools in one system. ATC chains thus allow for higher storage capacity under the same limited spatial conditions.

Design advantages

- The holding devices in the taper area are fitted with swell-resistant, low-wear plastic inserts ensuring a smooth mounting of the conical surface.
- The axial fixtures have been developed in a way that various dimensions are possible in one chain, e.g. DIN, ISO, ANSI as well as BT. Merely the ball holders must be exchanged respectively.
- By means of several position threads tool orientation may be selected (90° or 75°). Depending on the customers' requirements the axial force can be 100N - 500N.

* registered trademark of Sandvik Coromant

Application examples

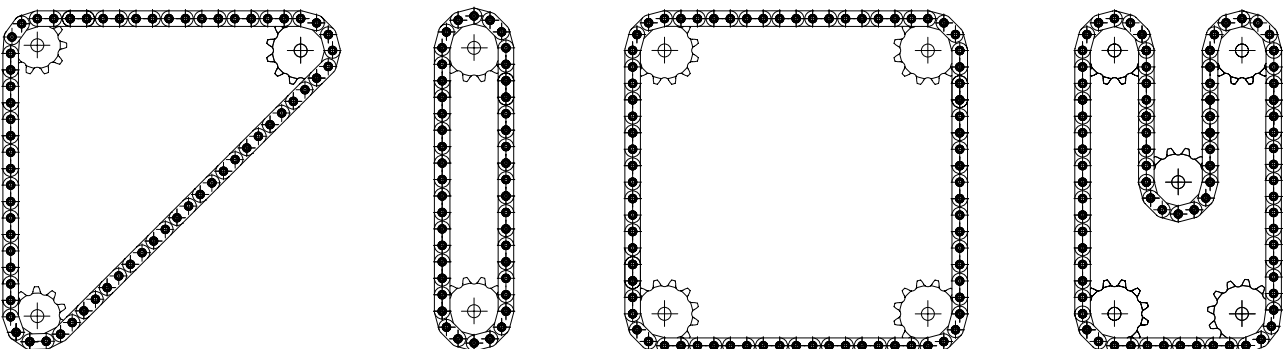

Tool securing

The simplest axial securing of tool holding attachments is achieved by means of ball locking devices with pre-stressed springs. With SK attachments the ball holders can be exchanged in the chain depending on the clamping spigot e.g. when changing from DIN to ANSI spigots.

However, this kind of axial securing is only advisable for standing or hanging arrangements with lightweight tools. Depending on

customers' requests pulling forces can be adjusted between 100N and 500N according to the respective system.

It is recommended to secure the tool holding attachments with locking pins, which are unlocked by means of pneumatic or hydraulic cylinders from the rear.

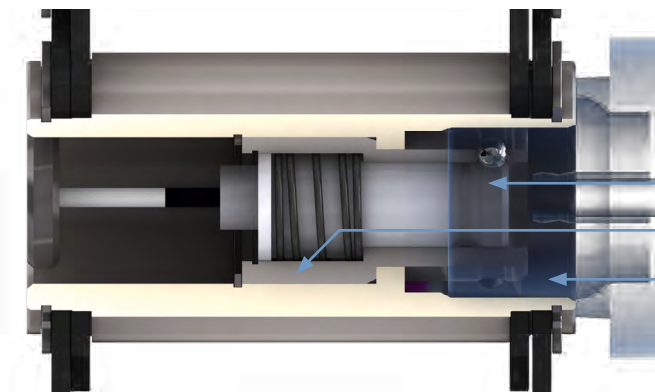

HSK 100

- Ball bushing
- Locking pin with ball locking device
- Tool holding device directly mounted without plastic bushing

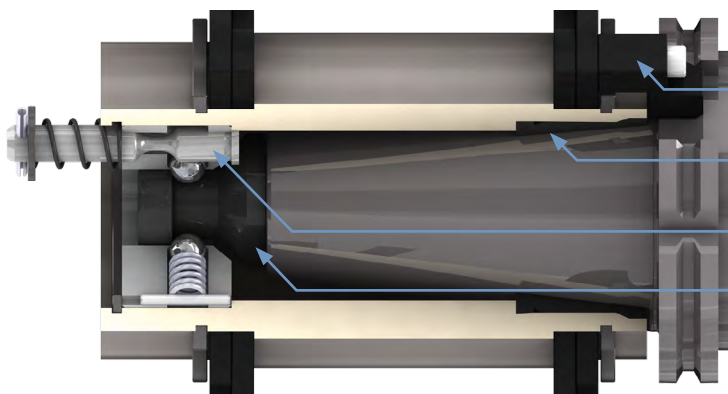

SK 50

- Tool positioner
- Swell-resistant, low-wear plastic insert
- Locking pin with ball locking device
- Pulling taper

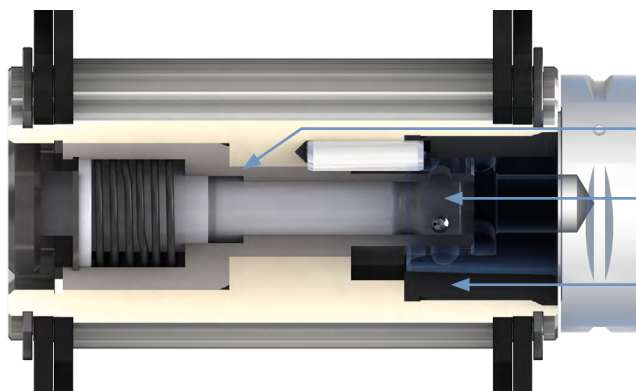

Capto^{®*}-C8

- Ball bushing
- Locking pin with ball locking device
- Swell-resistant, low-wear plastic insert

* registered trademark of Sandvik Coromant

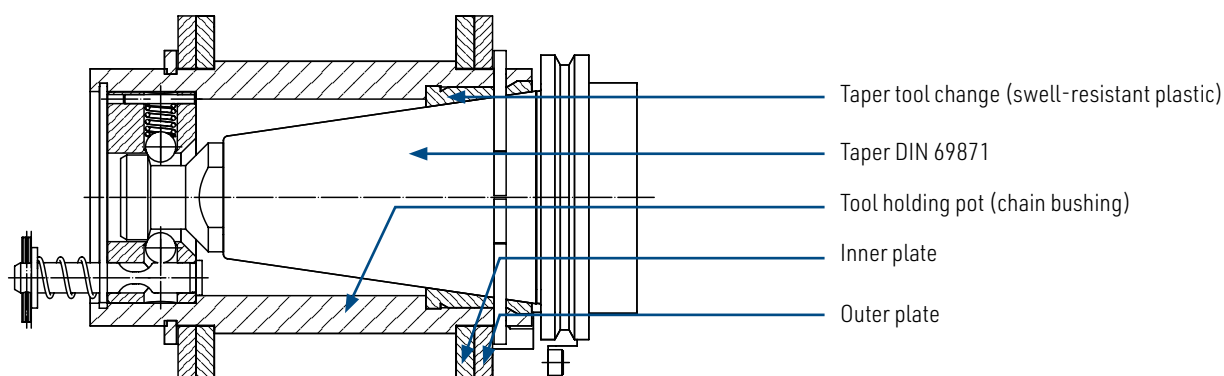
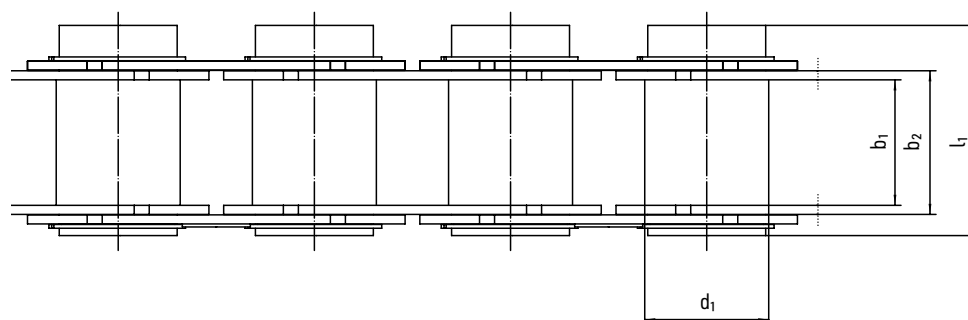
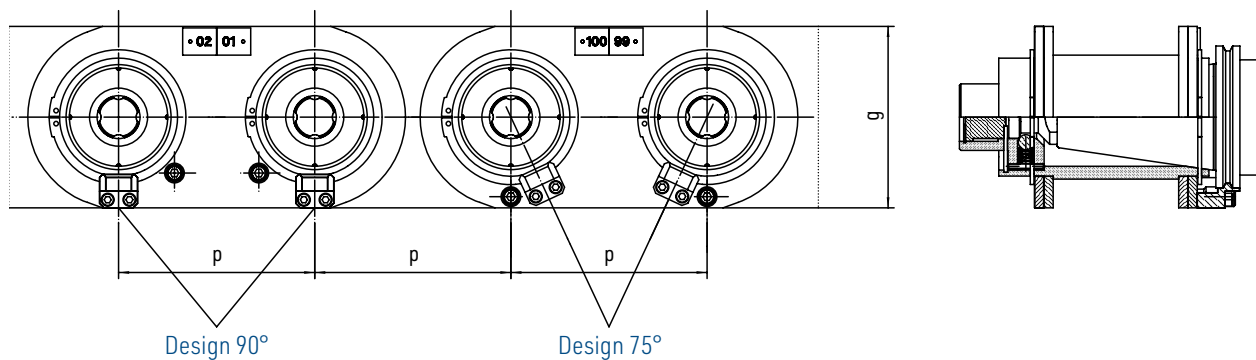

Chain		Pitch p min.	Inner width		Bushing \varnothing d_1 max.	Plate height g max.	Width over bushing l_1 max.	Projection over connecting link k max.	Taper design DIN 69871	Pulling taper				Bearing area g cm ²	Breaking load F_B min. N	Weight per tool holding attachment kg
No.	Ind.		b_1 min.	b_2 max.						ISO 7388	DIN 69872	MAST BT	ANSI Norm 45°			
320	²⁸	95	60,00	69,00	60,00	82,00	103,00	21,6	SK 40		X	X	X	4,74	90 000	2,0
340	²⁸	120	80,00	93,00	90,00	120,00	146,00	25,0	SK 50	X	X	X	9,60	190 000	5,3	

²⁸ larger pitch available on request

Can also be supplied for tool holding attachments HSK, HSZ and HSEZ!

**Customer Information**

Customer number Company

Contact person Ms. Mr.

Street

Postcode/zip code City

Telephone Telefax

Product Information

Tool holding attachments Type SK according to DIN EN ISO

Type HSK according to DIN EN ISO

Type Capto®* Type

Others

Pulling taper according to ISO 7388 DIN 69872 Mast-BT ANSI 45

Chain pitch mm Traversing speed m/s

Chain type 320 nominal pitch Pmin. = 95mm; Chain type 340 nominal pitch Pmin. = 120 mm up to 175 mm (other pitches and sizes on request)

Max. tool weight kg Max. tool diameter mm

Max. tool length mm Max- moment of tilt Nm

Tool axis arrangement (in tool holder) horizontal vertical standing hanging

Tool holder arrangement horizontal vertical

Number of tool pots pcs Distance with empty pots T = x P

For tools with larger diameters (e.g. milling heads) it is advantageous to choose a shorter chain pitch and only use every second or third tool pot since this will increase the smoothness of the chain drive.

Pick-up position of gripper on sprocket Z1 straight section

Position number Mechanical tool locking

Retention force of tool securing N

Angular position of tools in chain

e.g. in case of Z1-12 the demounting angle is 15°

in case of demounting on straight section it is 90°

Locking with spring force N

Information on sprockets

	Teeth	Bore Ø	Groove according to DIN 6885
Drive pinion Z1			
Deflection Z2			
Deflection Z3			
Deflection Z4			
Deflection Z5			

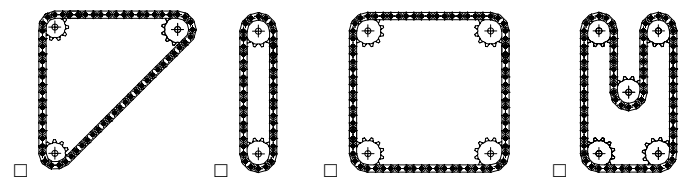
ATC chain arrangement**Additional information**

* registered trademark of Sandvik Coromant



Pusher dog

Secure transport of general cargo

During conveyance the WIPPERMANN pusher is at right angles to the chain. In the deflection phase it submerges under the transported material without damaging it.

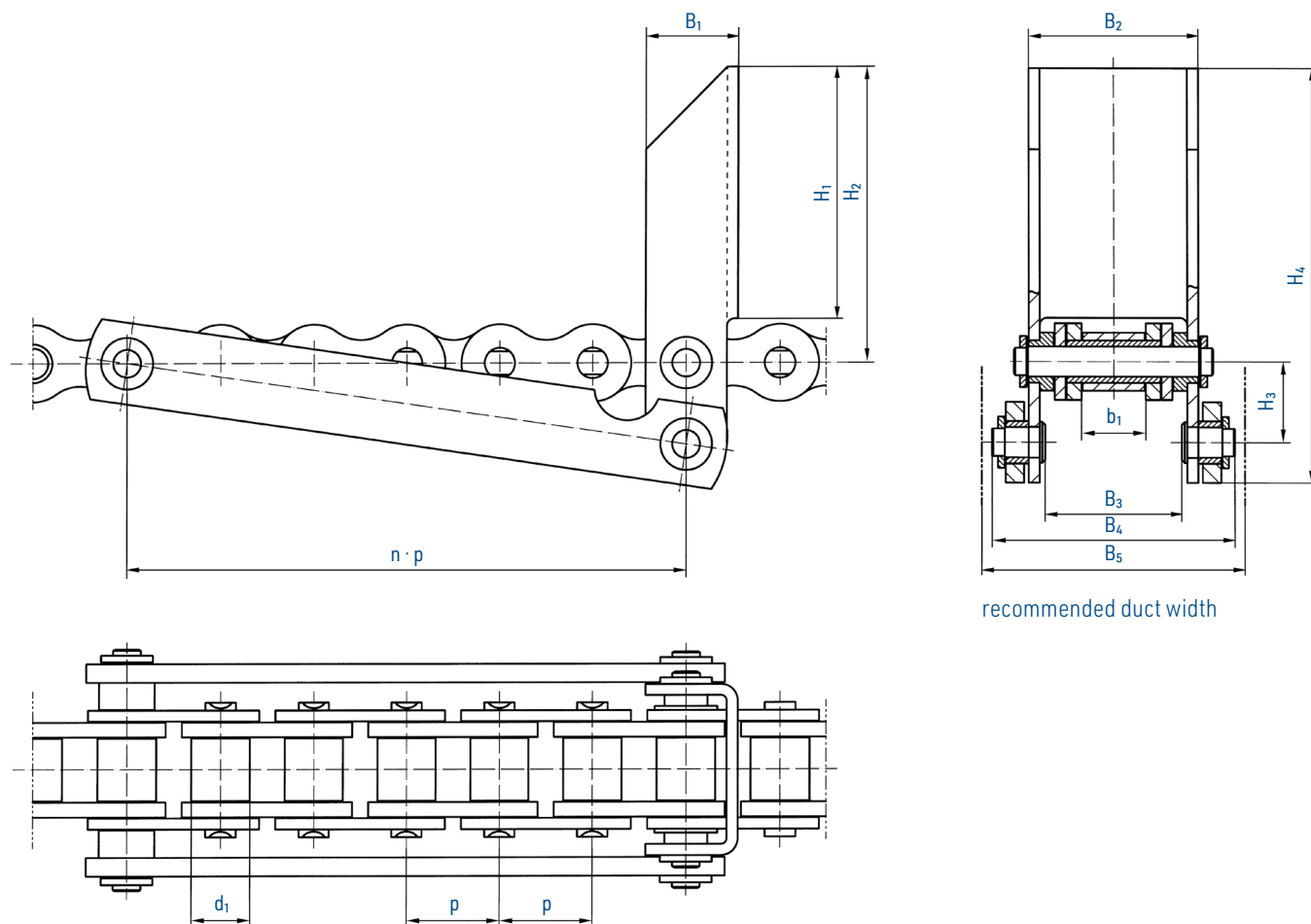

recommended duct width

Chain		Sprockets		Pitch p	Inner width b_1 min.	Roller \varnothing d_1 max.	Pusher dog dimensions									Thrust max. kN	
No.	Ind.	Number of teeth	Hub \varnothing max.				B_1	B_2	B_3	B_4	B_5	H_1	H_2	H_3	H_4		n
462 / M 120	¹⁰	20	32	12,700	7,75	8,51	18,0	25,0	19,0	35,0	40,0	22,0	29,0	11,0	46,0	5	0,5
501 / M 132	¹⁰	32	80	15,875	9,65	10,16	18,0	31,0	23,0	40,0	45,0	50,0	60,0	18,0	86,0	8	1,0
501 / M 133	¹⁰	24	60	15,875	9,65	10,16	18,0	31,0	23,0	40,0	45,0	50,0	60,0	14,0	82,0	6	1,0
548 / M 132	¹⁰	24	90	25,400	17,02	15,88	25,0	46,0	37,0	65,0	70,0	68,0	80,0	22,0	113,0	6	3,0

¹⁰ can also be supplied in stainless steel

All designs can also be supplied as MARATHON roller chains (maintenance-free), BIATHLON, BIATHLON KS, TRIATHLON and TRIATHLON KS! For details on orders and enquiries see page 149. For untoleranced dimensions DIN ISO 2768 c applies.

Special top plate conveyor chain

For cross-linking of systems

The main advantage compared to previous solutions is that the top plates are no component parts of the inner and outer links of the actual chain.

The plates are attached in the hollow pin as a separate assembly part. This specific DBGM protected construction characteristic (DBGM 295 05 477.8) allows for the top plates to be replaced even with a tensioned chain, i.e. the chain does not have to be separated.

Due to an additional short pin attached to the top plate the plate is twist-secured. The floating assembly of the top plate can compensate minor height differences of the slideways.

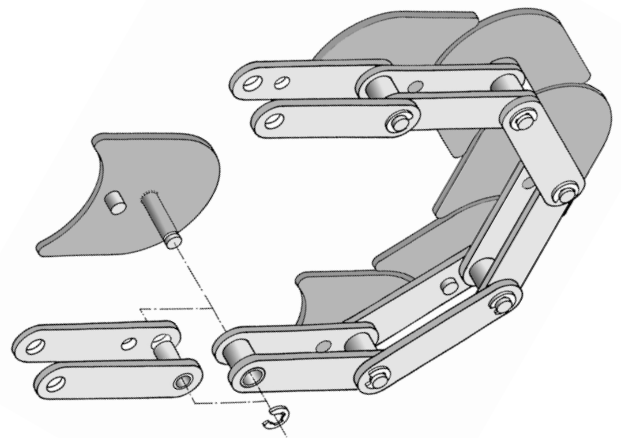

- Apart from that we have succeeded in considerably reducing the distance between the plates compared to previous solutions.
- The sickle-shaped conveyor plates allow unrestricted motion through narrow bends and curves.
- Owing to the special construction of the WIPERMANN special top plate conveyor chain an identical run of the top plate and the basic chain is guaranteed.
- In order to facilitate assembly and disassembly, the top plates were mounted with circlips.
- The WIPERMANN special top plate conveyor chain with its especially narrow chain plate construction ensures a larger bearing area of the top plates on the guide profiles.
- The top plates are coated and therefore have a high wear protection.
- The WIPERMANN special top plate conveyor chain is fully compatible with other systems.

Top plate conveyor chains suitable for following curved paths are installed in particular for long conveyor distances and high loads.

Primarily, they are required by the beverage and food industry and by subcontractors to the automotive industry.

Sprockets on request.

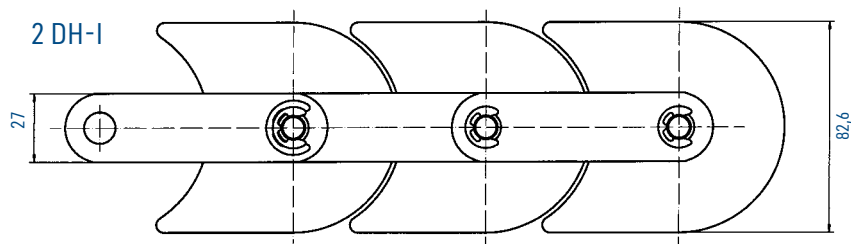

Chain	Weight	Minimum tensile strength
No.	kg/m	kN
2 DH-I	3,4	55,0

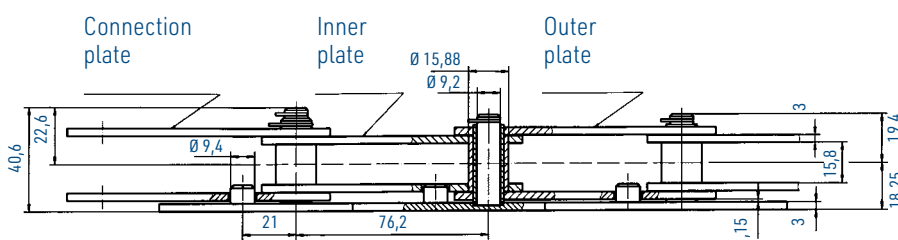

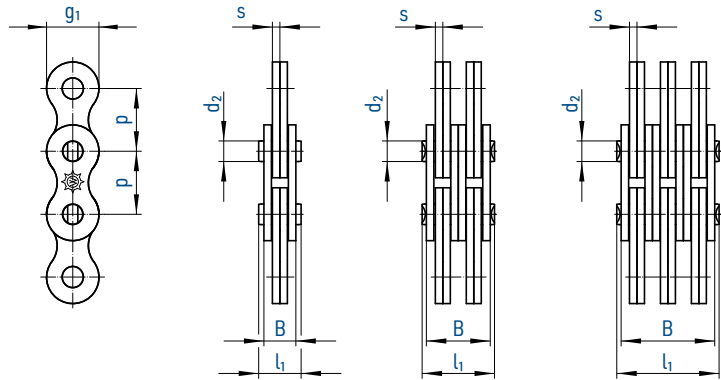

Abstract from ISO 4347

Chains may be assembled with chain parts according to ISO 606. Therefore the actual pitch may deviate from the nominal pitch. The permissible length deviation refers to the length specification of the manufacturer and is $\pm 0,25\%$ under the measuring force.

Chain		Nominal pitch		Lacing	Width over		Pin \varnothing	Plate		Effective length over 100 x pitch*	Bearing area $f \approx$	Breaking load ISO F_B min.	Weight $q \approx$	
	ISO	p			Pins**	Plates	d_2 max.	thickness s	height g_1 max.					
No.	Ind.	No.	mm	inch		l_1 max.	B max.	mm	mm	mm	cm ²	kN	kg/m	
F 122		LL 0822	12,700	1/2	2 x 2	8,5	6,4	4,45	1,55	10,92	1260	0,138	18,0	0,39
F 124		LL 0844	12,700	1/2	4 x 4	14,6	12,8	4,45	1,55	10,92	1260	0,276	36,0	0,74
F 126		LL 0866	12,700	1/2	6 x 6	20,7	19,0	4,45	1,55	10,92	1260	0,414	54,0	1,10
F 152		LL 1022	15,875	5/8	2 x 2	9,3	7,2	5,08	1,56	13,72	1580	0,175	22,0	0,50
F 154		LL 1044	15,875	5/8	4 x 4	16,1	14,5	5,08	1,56	13,72	1580	0,349	44,0	0,96
F 156		LL 1066	15,875	5/8	6 x 6	22,9	21,5	5,08	1,56	13,72	1580	0,524	66,0	1,39
F 192		LL 1222	19,050	3/4	2 x 2	10,7	7,8	5,72	1,90	16,13	1892	0,209	29,0	0,59
F 194		LL 1244	19,050	3/4	4 x 4	18,5	15,2	5,72	1,90	16,13	1892	0,419	58,0	1,15
F 196		LL 1266	19,050	3/4	6 x 6	25,4	22,6	5,72	1,90	16,13	1892	0,628	87,0	1,70
F 194 S		-	19,050	3/4	4 x 4	21,0	18,6	5,98	2,25	14,70	1905	0,515	76,5	1,40
F 196 S		-	19,050	3/4	6 x 6	31,5	27,8	5,98	2,25	14,70	1905	0,772	115,0	2,10
F 252		LL 1622	25,400	1	2 x 2	17,2	12,8	8,28	3,20	21,10	2532	0,500	60,0	1,56
F 254		LL 1644	25,400	1	4 x 4	30,2	25,6	8,28	3,20	21,10	2532	0,994	120,0	3,04
F 256		LL 1666	25,400	1	6 x 6	43,2	37,5	8,28	3,20	21,10	2532	1,490	180,0	4,53
F 312		LL 2022	31,750	1 1/4	2 x 2	20,1	16,0	10,19	3,70	26,40	3170	0,750	95,0	2,01
F 314		LL 2044	31,750	1 1/4	4 x 4	35,1	32,0	10,19	3,70	26,40	3170	1,500	190,0	3,93
F 316		LL 2066	31,750	1 1/4	6 x 6	50,1	48,0	10,19	3,70	26,40	3170	2,250	285,0	5,86
F 382		LL 2422	38,100	1 1/2	2 x 2	28,4	21,0	14,63	5,20	33,20	3797	1,460	170,0	4,18
F 384		LL 2444	38,100	1 1/2	4 x 4	49,4	42,0	14,63	5,20	33,20	3797	2,930	340,0	8,48
F 386		LL 2466	38,100	1 1/2	6 x 6	70,4	62,0	14,63	5,20	33,20	3797	4,390	510,0	12,20
F 502		LL 3222	50,800	2	2 x 2	35,0	25,0	17,81	6,45	42,30	5070	2,140	260,0	6,73
F 504		LL 3244	50,800	2	4 x 4	61,0	50,0	17,81	6,45	42,30	5070	4,280	520,0	12,70
F 506		LL 3266	50,800	2	6 x 6	87,0	74,0	17,81	6,45	42,30	5070	6,420	780,0	19,50
F 508		LL 3288	50,800	2	8 x 8	105,5	99,0	17,81	6,45	42,30	5070	8,560	1050,0	25,80
F 501		LL 3110	50,800	2	10 x 10	130,0	123,0	17,81	6,45	42,30	5070	10,850	1330,0	31,56
F 632		LL 4022	63,500	2 1/2	2 x 2	44,7	33,2	22,89	8,25	53,00	6335	3,525	360,0	10,51
F 634		LL 4044	63,500	2 1/2	4 x 4	77,9	65,6	22,89	8,25	53,00	6335	7,050	720,0	20,29
F 636		LL 4066	63,500	2 1/2	6 x 6	111,1	98,0	22,89	8,25	53,00	6335	10,575	1080,0	29,74
F 638		LL 4088	63,500	2 1/2	8 x 8	136,0	130,4	22,89	8,25	53,00	6335	14,100	1690,0	39,30

* Chain length tolerance $\pm 0,25\%$ of uncoiled chain under measuring force. ** for riveted pins

For ordering examples, end links and connecting pins see page 85.

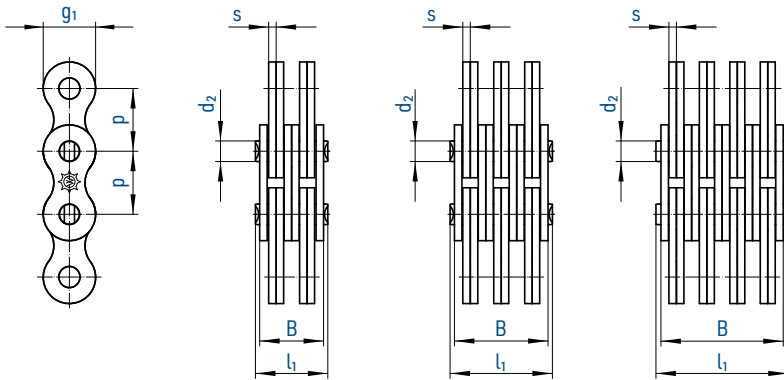

Chain		Nominal pitch		Lacing	Width over		Pin Ø	Plate		Effective length over 100 x pitch*	Bearing area	Breaking load	Weight
⚙️		p			Pins	Plates		thickness	height				
No.	Ind.	mm	inch		l ₁ max.	B max.	d ₂ max.	s	g ₁ max.		f ≈	F _B min.	q ≈
					mm	mm	mm	mm	mm	mm	cm ²	kN	kg/m
FU 154		15,875	5/8	4 x 4	17,1	14,5	5,08	1,65	14,4	1596	0,350	52,0	1,2
FU 156		15,875	5/8	6 x 6	24,1	21,5	5,08	1,65	14,4	1596	0,524	78,0	1,8
FU 158		15,875	5/8	8 x 8	30,9	28,0	5,08	1,65	14,4	1596	0,699	102,0	2,3
FU 156 S		15,875	5/8	6 x 6	27,5	25,0	5,08	2,05	14,7	1596	0,625	83,5	2,1
FU 194		19,050	3/4	4 x 4	18,1	15,2	5,72	1,83	16,1	1907	0,419	66,0	1,4
FU 196		19,050	3/4	6 x 6	25,4	22,6	5,72	1,83	16,1	1907	0,628	99,0	2,3
FU 196 S		19,050	3/4	6 x 6	31,7	28,8	6,50	2,35	18,1	1907	0,917	130,0	2,9
FU 254		25,400	1	4 x 4	29,3	25,6	8,28	3,00	23,0	2550	0,994	140,0	3,5
FU 256		25,400	1	6 x 6	41,3	37,5	8,28	3,00	23,0	2550	1,490	210,0	5,0
FU 258		25,400	1	8 x 8	53,1	49,0	8,28	3,00	23,0	2550	1,987	280,0	6,8

* Chain length tolerance ± 0,25 % of uncoiled chain under measuring force.

For ordering examples, end links and connecting pins see page 85.
For information on the selection of chain sizes see pages 134/135.

Leaf chains heavy duty design U

according to factory standard

With chains of this type all plates are mounted with a sliding fit and are also secured with laterally attached riveted washers. This design guarantees an even load distribution and reduces the bending load of the pin. These chains have been designed to transport heavy loads under harsh conditions. They are particularly suitable for such applications due to their high fatigue strength.

Chain		Nominal pitch		Lacing	Width over		Pin Ø	Plate		Effective length over 100 x pitch*	Bearing area	Breaking load	Weight
⚙️		p			Pins	Plates		thickness	height				
No.	Ind.	mm	inch		l ₁ max.	B max.	d ₂ max.	s	g ₁ max.		f ≈	F _B min.	q ≈
					mm	mm	mm	mm	mm	mm	cm ²	kN	kg/m
F 384 U		38,1	1 1/2	4 x 4	53,2	42,0	14,63	5,00	33,4	3802	2,926	354,0	9,1
F 386 U		38,1	1 1/2	6 x 6	75,2	62,0	14,63	5,00	33,4	3802	4,389	540,0	12,5
F 388 U		38,1	1 1/2	8 x 8	94,2	83,0	14,63	5,00	33,4	3802	5,852	700,0	16,5
F 504 U		50,8	2	4 x 4	60,2	50,0	17,81	6,00	43,0	5073	4,274	530,0	13,5
F 506 U		50,8	2	6 x 6	87,2	74,0	17,81	6,00	43,0	5073	6,412	800,0	20,0
F 508 U		50,8	2	8 x 8	111,2	99,0	17,81	6,00	43,0	5073	8,549	1050,0	26,5
F 501 U		50,8	2	10 x 10	135,0	123,0	17,81	6,00	43,0	5073	10,686	1330,0	33,1
F 634 U		63,5	2 1/2	4 x 4	81,2	70,0	22,89	8,00	52,0	6340	5,494	845,0	19,4
F 636 U		63,5	2 1/2	6 x 6	112,2	101,0	22,89	8,00	52,0	6340	10,990	1270,0	29,1
F 638 U		63,5	2 1/2	8 x 8	146,0	135,0	22,89	8,00	52,0	6340	14,650	1690,0	38,8

* Chain length tolerance ± 0,25 % of uncoiled chain under measuring force.

For ordering examples, end links and connecting pins see page 85.
For information on the selection of chain sizes see pages 134/135.

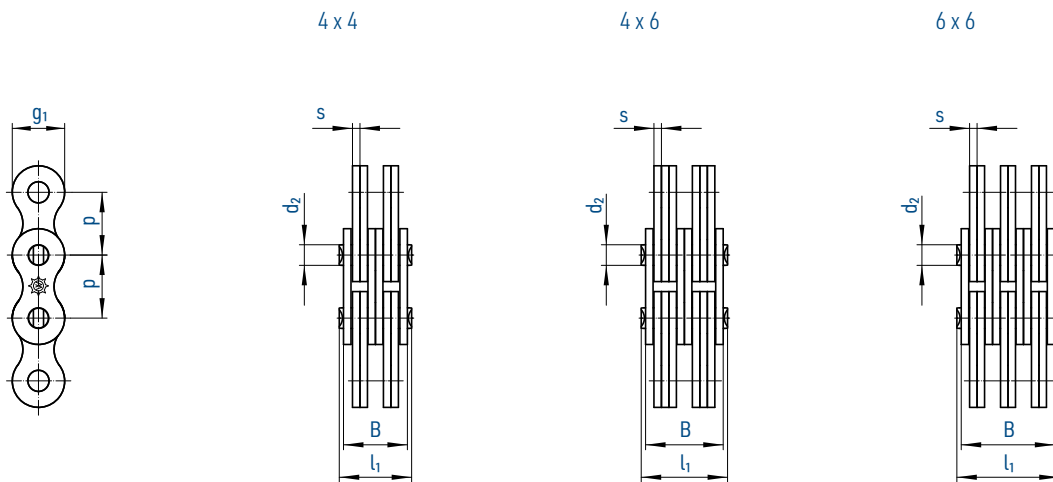

Chain			Nominal pitch		Lacing	Width over		Pin Ø d ₂ max.	Plate		Effective length over 100 x pitch*	Bearing area f ≈ cm ²	Breaking load ISO F _B min. kN	Weight q ≈ kg/m
No.	Ind.	ISO	p			Pins**	Plates		thickness	height				
		Nr.	mm	inch	l ₁ max. mm	B max. mm	s mm	g ₁ max. mm						
BL 544		LH 1044	15,875	5/8	4 x 4	22,8	20,0	5,96	2,48	15,1	1592	0,570	66,7	1,86
BL 546		LH 1046	15,875	5/8	4 x 6	27,7	24,8	5,96	2,48	15,1	1592	0,860	66,7	2,32
BL 566		LH 1066	15,875	5/8	6 x 6	32,7	29,7	5,96	2,48	15,1	1592	0,860	100,1	2,77
BL 844		LH 1644	25,400	1	4 x 4	37,9	33,2	9,54	4,09	24,1	2544	1,490	169,0	4,72
BL 846		LH 1646	25,400	1	4 x 6	46,2	41,4	9,54	4,09	24,1	2544	2,230	169,0	5,88
BL 866		LH 1666	25,400	1	6 x 6	54,4	49,4	9,54	4,09	24,1	2544	2,230	253,6	7,04

* Chain length tolerance ± 0,25 % of uncoiled chain under measuring force. ** for riveted pins

For a pre-selection of leaf chains see page 134/135.

Inner end link 4 x 4

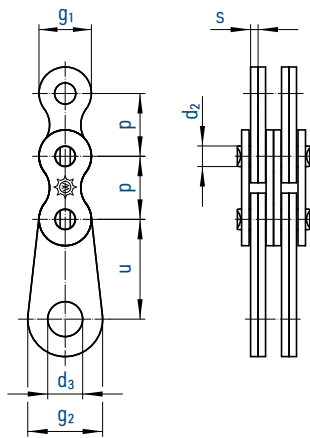

Outer end link 4 x 4

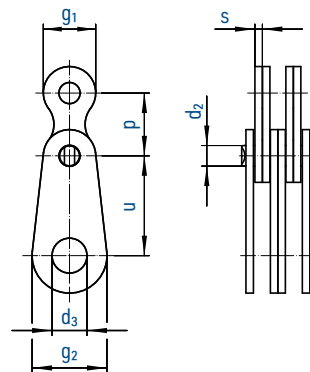

Connecting pin

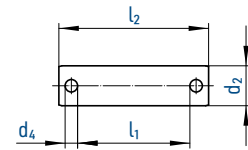

Leaf chains are only supplied with end links on customers' request. The design with either outer or inner end link must be stated in the order.

Design of chain ends:

Only the normal links are counted

- A Both sides with inner end links (uneven number of links)
- B Both sides with outer end links (uneven number of links)
- C One side with inner end link, other side with outer end link (even number of links)
- D One side with inner end link, other side with inner link (uneven number of links)
- E One side with outer end link, other side with outer link (uneven number of links)
- F One side with inner end link, other side with outer link (even number of links)
- G One side with outer end link, other side with inner link (even number of links)
- H Both sides with inner links (uneven number of links)
- I Both sides with outer links (uneven number of links)
- K One side with inner link, other side with outer link (even number of links)

Designation of a leaf chain design A with 25,4 mm pitch, combination 4 x 4, 45 normal links and end links on both sides:
F 254 A x 45

Chain		Nominal pitch		End plates								Connecting pins							
				u	d ₂	d ₃	g ₁	g ₂	s	d ₂	d ₄	2 x 2		4 x 4		6 x 6		8 x 8	
⚙	p										L ₁	L ₂	L ₁	L ₂	L ₁	L ₂	L ₁	L ₂	
No.	Ind.	mm	inch	mm	mm	mm	mm	mm	mm	mm	mm	mm	mm	mm	mm	mm	mm	mm	mm
F 12		12,700	1/2	30	4,45	10,0	10,5	20	1,55	4,45	1,6	6,8	13,0	13,6	19,8	20,4	26,6	-	-
F 15		15,875	5/8	30	5,08	10,0	12,5	20	1,70	5,08	1,6	7,4	13,6	14,8	21,0	21,8	28,0	-	-
F 19		19,050	3/4	30	5,72	10,0	14,5	20	1,80	5,72	1,6	8,0	14,2	15,4	21,6	22,9	29,1	-	-
F 25		25,400	1	45	8,28	16,0	21,0	35	3,00	8,28	3,4	13,0	23,8	25,9	36,7	38,0	48,8	51,0	61,8
F 31		31,750	1 1/4	45	10,19	16,0	24,5	35	3,80	10,19	3,4	16,4	27,2	32,4	43,2	48,5	59,3	64,8	75,6
F 38		38,100	1 1/2	60	14,63	26,0	33,0	50	5,00	14,63	4,2	21,3	33,7	42,4	54,8	63,5	75,9	84,8	97,2
F 50		50,800	2	70	17,81	36,0	43,0	70	6,00	17,81	4,2	25,5	37,9	50,5	62,9	75,5	87,9	100,7	113,0
F 63		63,500	2 1/2	90	22,89	45,0	52,0	80	8,00	22,89	5,2	-	-	66,4	86,8	99,6	120,0	132,8	153,2
FU 12		12,700	1/2	30	4,45	10,0	11,5	20	1,55	4,45	1,6	-	-	13,6	19,8	20,4	26,6	-	-
FU 15		15,875	5/8	30	5,08	10,0	14,5	20	1,70	5,08	1,6	-	-	14,8	21,0	21,8	28,0	28,3	34,5
FU 15 S		15,875	5/8	20	5,08	8,3	14,7	18	2,00	5,08	1,6	-	-	-	-	30,9	37,5	-	-
FU 19		19,050	3/4	30	5,72	10,0	15,4	20	1,80	5,72	1,6	-	-	15,4	21,6	22,9	29,1	-	-
FU 19 S		19,050	3/4	25	6,50	10,3	18,0	20	2,30	6,50	1,6	-	-	19,6	25,8	29,3	35,5	-	-
FU 25		25,400	1	45	8,28	16,0	21,0	35	3,00	8,28	3,4	-	-	25,9	36,7	38,0	48,8	51,0	61,8
F 38 U		38,100	1 1/2	60	14,63	26,0	33,0	50	5,00	14,63	4,2	-	-	48,4	61,0	70,0	82,4	90,8	103,2
F 50 U		50,800	2	70	17,81	36,0	43,0	70	6,00	17,81	4,2	-	-	56,5	68,9	81,5	93,9	106,8	119,2
F 63 U		63,500	2 1/2	90	22,89	45,0	52,0	80	8,00	22,89	5,2	-	-	72,4	92,8	105,6	126,0	138,8	159,2

Other dimensions on request.

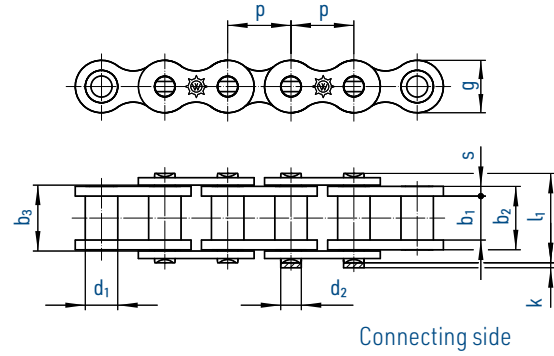

Chain		Pitch	Inner width	Inner link width	Outer plate width	Bushing Ø	Pin Ø	Width over pin	Projection over connecting link	Plate thickness	Plate height	Bearing area	Breaking load DIN	Weight	Connecting links
⚙		p	b ₁ min.	b ₂ max.	b ₃ min.	d ₁ max.	d ₂ max.	l ₁ max.	k max.	s	g max.	f	F _B min.	q ≈	Nr.
No.	Ind.	mm	mm	mm	mm	mm	mm	mm	mm	mm	mm	cm ²	kN	kg/m	
200	²⁶	15,0	14,0	18,50	19,00	9,0	6,0	26,0	2,0	2,00	14,0	1,1	12,5	1,25	111,12
203	²⁶	20,0	16,0	22,50	23,00	12,0	8,0	33,0	3,0	3,00	19,0	1,8	25,0	2,10	111,11,12
206	²⁶	25,0	18,0	24,50	25,00	15,0	10,0	37,0	3,5	3,00	24,0	2,5	31,5	2,60	111,12
209	²⁶	30,0	20,0	28,50	29,00	17,0	11,0	43,0	3,5	4,00	28,0	3,1	40,0	4,00	111,12
212	²⁶	35,0	22,0	30,50	31,00	18,0	12,0	46,0	4,5	4,00	30,0	3,7	50,0	4,30	111,12
215	²⁶	40,0	25,0	35,50	36,00	20,0	14,0	53,0	4,5	5,00	35,0	5,0	63,0	6,00	111,12
218	²⁶	45,0	30,0	42,50	43,00	22,0	16,0	63,0	4,5	6,00	40,0	6,8	80,0	8,00	111,12
221	²⁶	50,0	35,0	47,50	48,00	26,0	18,0	68,0	6,0	6,00	44,00	8,6	100,0	9,00	111,12
222	²⁶	55,0	45,0	61,50	62,50	30,0	20,0	86,0	7,0	8,00	49,00	12,3	125,0	13,60	111,12
223	²⁶	60,0	50,0	66,50	67,50	32,0	22,0	93,0	7,0	8,00	55,00	14,6	160,0	14,90	111,12
224	²⁶	65,0	55,0	72,00	73,00	36,0	26,0	98,0	8,0	8,00	61,00	18,7	200,0	18,90	111,12
225	²⁶	70,0	65,0	86,00	87,00	42,0	30,0	117,0	8,0	10,00	67,00	25,8	250,0	24,70	111,12

²⁶ Connecting link No. 111 (S) with double cottered pin, i.e. projection k on both chain sides

For details on orders and enquiries see page 148. Sprockets on request.

Chain speeds with bush chains up to a pitch:

- of 20 mm ... up to 5 m/s
- of 40 mm ... up to 4 m/s
- more than 40 mm ... up to 3 m/s

Connecting links: According to ISO (...)



No. 4 (B)
Inner link



No. 7 (A)
Outer link
(to be riveted)



No. 11 (E)
Spring clip
connecting link



No. 111 (S)
Connecting link
with cottered pin



No. 12 (L)
Single
cranked link

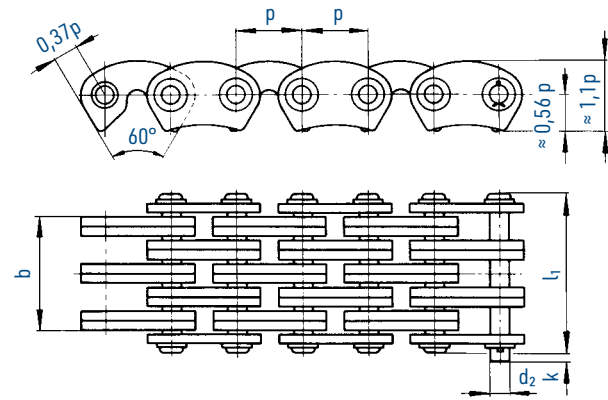
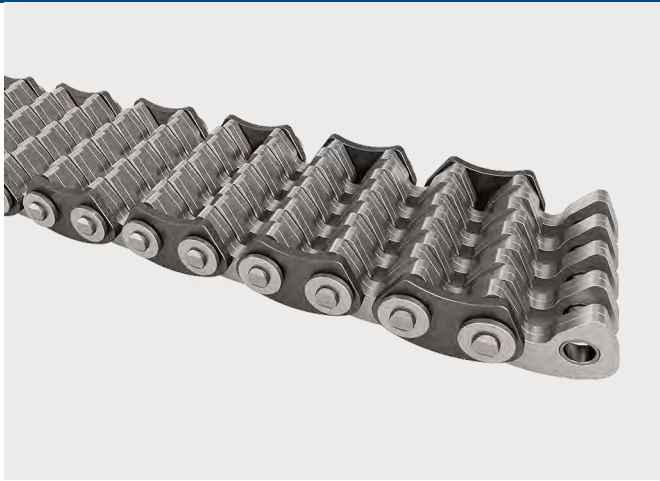

Outer guide system

Chain		Pitch	Lacing	Working width	Overall width	Pin Ø	Projection over connecting link	Bearing area	Breaking load	Weight
		p		b min.	l ₁ max.	d ₂ max.	k	f	FB min.	q ≈
No.	Ind.	mm		mm	mm	mm	mm		kN	kg/m
1110		10,0	1 x 2	9,6	17,6	3,15	1,6	0,20	11,0	0,64
1112		10,0	2 x 3	16,0	24,1	3,15	1,6	0,29	17,0	0,93
1114		10,0	4 x 5	28,9	37,1	3,15	1,6	0,49	28,0	1,56
1115		10,0	5 x 6	35,2	43,4	3,15	1,6	0,59	34,0	1,88

Inverted tooth chain sprockets on request.

When ordered by length in metres, the chain will contain the next higher even number of links with a connecting pin. When ordered by number of links, the chain will be supplied with an uneven number of links and include a single cranked link riveted into the chain as well as a connecting pin.

Connecting links: According to ISO (...)



No. 10
Connecting pin



No. 52
Cranked three-joint connecting link



No. 53
Straight two-joint connecting link

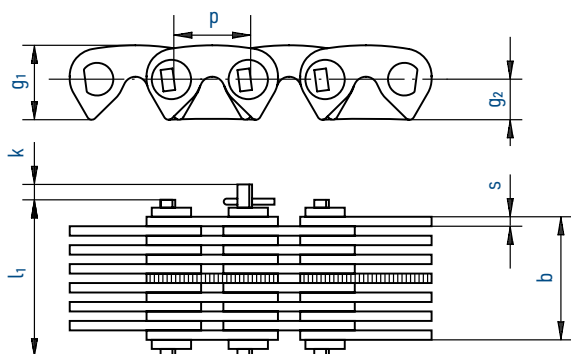
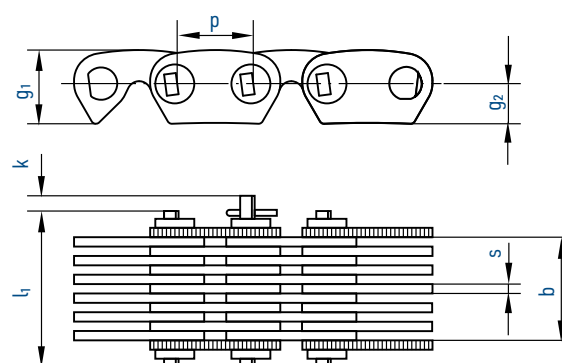

Inner guide system (J)

Outer guide system (A)

Chain		Pitch	Working width	Overall width	Plate height		Plate thickness	Projection over connecting link	Number of rows*	Breaking load	Tooth width	Weight
⚙		p	b min.	l ₁ max.	g ₁ max.	g ₂	s	k	RZ	F _B min.		q ≈
No.	Ind.	mm	mm	mm	mm	mm	mm	mm		kN	mm	kg/m
06-015A		9,525	12,5	20,0	9,2	5,2	1,50	2,0	10	12,1	11,5	0,80
06-020A		9,525	17,2	24,5	9,2	5,2	1,50	2,0	13	14,8	16,0	1,00
06-025J		9,525	26,6	31,0	9,2	5,2	1,50	2,0	17	22,9	30,0	1,10
06-030J		9,525	33,0	37,1	9,2	5,2	1,50	2,0	21	28,3	35,0	1,40
06-035J		9,525	39,1	43,5	9,2	5,2	1,50	2,0	25	33,7	40,0	1,70
08-015A		12,700	12,5	21,5	12,3	6,7	1,50	2,5	10	16,0	11,5	1,00
08-020A		12,700	17,2	26,0	12,3	6,7	1,50	2,5	13	19,6	16,0	1,20
08-025J		12,700	26,6	32,5	12,3	6,7	1,50	2,5	17	30,3	30,0	1,40
08-030J		12,700	33,0	39,0	12,3	6,7	1,50	2,5	21	37,4	35,0	1,80
08-035J		12,700	39,1	45,0	12,3	6,7	1,50	2,5	25	44,6	40,0	2,10
08-050J		12,700	51,6	58,0	12,3	6,7	1,50	2,5	33	58,9	55,0	2,80
08-065J		12,700	64,2	69,8	12,3	6,7	1,50	2,5	41	73,1	70,0	3,50
10-025J		15,875	27,0	33,0	15,4	8,4	2,00	3,0	13	39,7	30,0	1,90
10-035J		15,875	35,5	41,5	15,4	8,4	2,00	3,0	17	52,0	40,0	2,50
10-040J		15,875	43,7	49,5	15,4	8,4	2,00	3,0	21	64,2	45,0	3,00
10-050J		15,875	52,0	58,0	15,4	8,4	2,00	3,0	25	76,5	55,0	3,60
10-065J		15,875	69,0	75,4	15,4	8,4	2,00	3,0	33	100,9	70,0	4,80
12-035J		19,050	35,5	43,0	18,5	10,1	2,00	3,5	17	65,0	40,0	2,90
12-040J		19,050	44,0	51,0	18,5	10,1	2,00	3,5	21	80,3	45,0	3,60
12-050J		19,050	52,0	59,0	18,5	10,1	2,00	3,5	25	95,6	55,0	4,30
12-065J		19,050	68,6	76,0	18,5	10,1	2,00	3,5	33	126,2	70,0	5,70
12-075J		19,050	77,0	84,0	18,5	10,1	2,00	3,5	37	141,5	80,0	6,40
16-050J		25,400	53,0	61,0	25,0	13,1	3,00	4,0	17	126,4	55,0	5,90
16-065J		25,400	65,0	73,0	25,0	13,1	3,00	4,0	21	156,1	70,0	7,30
16-075J		25,400	77,5	85,5	25,0	13,1	3,00	4,0	25	185,9	80,0	8,70
16-100J		25,400	103,0	111,0	25,0	13,1	3,00	4,0	33	245,4	105,0	11,40
16-125J		25,400	127,0	135,0	25,0	13,1	3,00	4,0	41	304,9	130,0	14,20
24-065J		38,100	65,5	77,5	37,0	20,1	3,00	6,0	21	232,0	75,0	10,80
24-075J		38,100	78,0	90,0	37,0	20,1	3,00	6,0	25	276,2	85,0	12,90
24-100J		38,100	103,0	115,0	37,0	20,1	3,00	6,0	33	364,6	110,0	17,00
24-125J		38,100	127,5	139,5	37,0	20,1	3,00	6,0	41	453,0	135,0	21,10
24-150J		38,100	153,0	165,0	37,0	20,1	3,00	6,0	49	541,4	160,0	25,20
32-100J		50,800	104,5	117,5	49,2	26,8	4,00	7,0	25	478,1	110,0	22,60
32-115J		50,800	121,2	135,0	49,2	26,8	4,00	7,0	29	554,8	125,0	26,20
32-135J		50,800	138,0	151,0	49,2	26,8	4,00	7,0	33	631,1	145,0	29,80
32-150J		50,800	154,7	167,7	49,2	26,8	4,00	7,0	37	707,6	160,0	33,50
32-180J		50,800	188,1	201,1	49,2	26,8	4,00	7,0	45	860,6	190,0	40,70

* Plates on one pivot pin

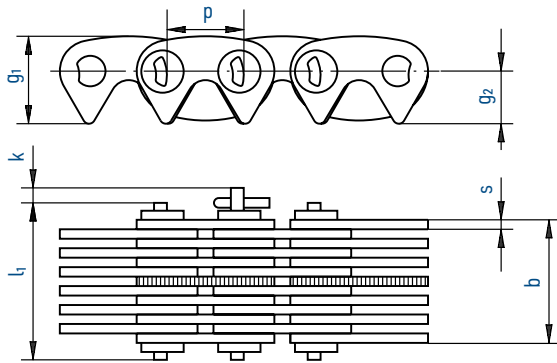
Inverted tooth chain sprockets on request.

When ordered by length in metres, the chain will contain the next higher even number of links with a connecting pin. For this type of inverted tooth chain no cranked links are available.



Inner guide system (J)

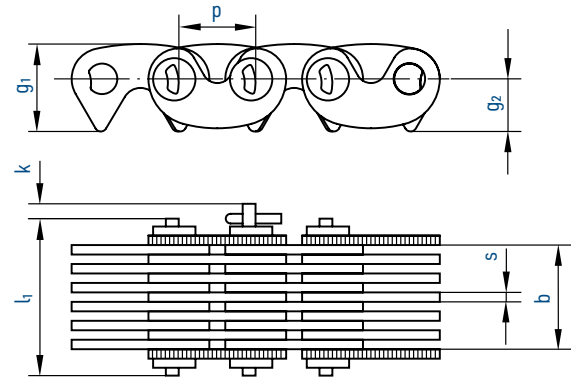

Outer guide system (A)

Chain		Pitch	Working width	Overall width	Plate height		Plate thickness	Projection over connecting link	Number of rows*	Breaking load	Tooth width	Weight
		p	b min.	l ₁ max.	g ₁ max.	g ₂	s	k	RZ	FB min.		q ≈
No.	Ind.	mm	mm	mm	mm	mm	mm	mm		kN	mm	kg/m
HD 06-015A		9,525	12,5	19,9	10,9	6,7	1,50	2,0	10,0	14,5	11,5	0,90
HD 06-020A		9,525	17,2	24,5	10,9	6,7	1,50	2,0	13,0	17,7	16,0	1,10
HD 06-025J		9,525	26,6	30,8	10,9	6,7	1,50	2,0	17,0	27,4	30,0	1,40
HD 06-030J		9,525	32,9	37,1	10,9	6,7	1,50	2,0	21,0	33,9	35,0	1,70
HD 06-040J		9,525	39,1	43,3	10,9	6,7	1,50	2,0	25,0	40,3	45,0	2,00
HD 06-050J		9,525	51,6	55,8	10,9	6,7	1,50	2,0	33,0	53,2	55,0	2,60
HD 06-065J		9,525	64,2	68,4	10,9	6,7	1,50	2,0	41,0	66,2	70,0	3,30
HD 08-015A		12,700	12,5	21,3	14,5	8,7	1,50	2,5	10,0	20,2	11,5	1,10
HD 08-020A		12,700	17,2	25,9	14,5	8,7	1,50	2,5	13,0	24,7	16,0	1,40
HD 08-025J		12,700	26,6	32,2	14,5	8,7	1,50	2,5	17,0	38,2	30,0	1,80
HD 08-030J		12,700	32,9	38,5	14,5	8,7	1,50	2,5	21,0	47,3	35,0	2,20
HD 08-040J		12,700	39,1	44,7	14,5	8,7	1,50	2,5	25,0	56,3	45,0	2,60
HD 08-050J		12,700	51,6	57,2	14,5	8,7	1,50	2,5	33,0	74,3	55,0	3,40
HD 08-065J		12,700	64,2	69,8	14,5	8,7	1,50	2,5	41,0	92,3	70,0	4,30
HD 08-075J		12,700	76,7	82,3	14,5	8,7	1,50	2,5	49,0	110,3	80,0	5,10
HD 08-100J		12,700	101,7	107,3	14,5	8,7	1,50	2,5	65,0	146,4	105,0	6,70
HD 12-030A		19,050	27,0	38,2	21,0	10,7	2,00	3,5	15,0	59,6	25,0	3,30
HD 12-035J		19,050	35,4	42,4	21,0	10,7	2,00	3,5	17,0	78,0	40,0	3,70
HD 12-040J		19,050	43,7	50,7	21,0	10,7	2,00	3,5	21,0	96,3	50,0	4,50
HD 12-050J		19,050	52,0	59,0	21,0	10,7	2,00	3,5	25,0	114,7	55,0	5,40
HD 12-065J		19,050	68,6	75,6	21,0	10,7	2,00	3,5	33,0	151,4	70,0	7,10
HD 12-085J		19,050	85,3	92,3	21,0	10,7	2,00	3,5	41,0	188,1	90,0	8,90
HD 12-100J		19,050	101,9	108,9	21,0	10,7	2,00	3,5	49,0	224,9	105,0	10,60
HD 12-125J		19,050	126,9	133,9	21,0	10,7	2,00	3,5	61,0	279,9	130,0	13,20
HD 12-150J		19,050	151,8	158,8	21,0	10,7	2,00	3,5	73,0	335,0	155,0	15,80
HD 12-200J		19,050	201,8	208,8	21,0	10,7	2,00	3,5	97,0	445,2	205,0	20,90
HD 16-040J		25,400	40,2	48,2	27,7	14,0	3,00	6,0	13,0	112,1	45,0	5,60
HD 16-050J		25,400	52,6	60,6	27,7	14,0	3,00	6,0	17,0	146,6	55,0	7,30
HD 16-065J		25,400	65,0	73,0	27,7	14,0	3,00	6,0	21,0	181,1	70,0	9,00
HD 16-075J		25,400	77,4	85,4	27,7	14,0	3,00	6,0	25,0	215,6	80,0	10,70
HD 16-100J		25,400	102,1	110,1	27,7	14,0	3,00	6,0	33,0	284,7	105,0	14,10
HD 16-125J		25,400	126,9	134,9	27,7	14,0	3,00	6,0	41,0	353,7	130,0	17,50
HD 16-150J		25,400	151,7	159,7	27,7	14,0	3,00	6,0	49,0	422,7	155,0	21,00
HD 16-200J		25,400	201,2	209,2	27,7	14,0	3,00	6,0	65,0	560,7	205,0	27,80

* Plates on one pivot pin

Inverted tooth chain sprockets on request.

When ordered by length in metres, the chain will contain the next higher even number of links with a connecting pin. For this type of inverted tooth chain no cranked links are available.

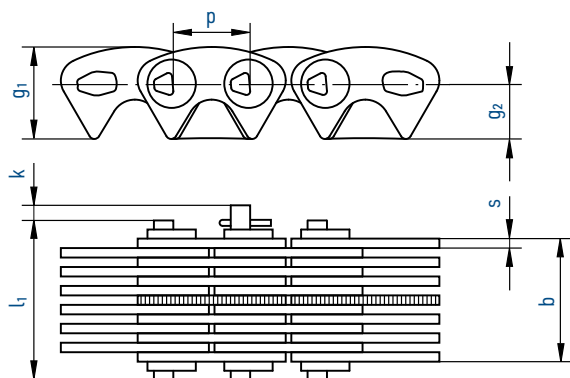
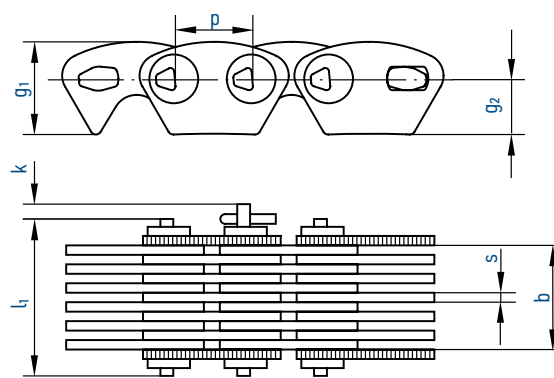
Inner guide system (J)

Outer guide system (A)

Chain		Pitch	Working width	Overall width	Plate height		Plate thickness	Projection over connecting link	Number of rows*	Breaking load	Tooth width	Weight
		p	b min.	l ₁ max.	g ₁ max.		s	k	RZ	FB min.		q ≈
No.	Ind.	mm	mm	mm	mm	mm	mm	mm		kN	mm	kg/m
HP 06-015A		9,525	12,5	19,9	11,3	6,8	1,50	2,0	10,0	25,4	11,5	1,00
HP 06-020A		9,525	17,2	24,5	11,3	6,8	1,50	2,0	13,0	30,1	16,0	1,20
HP 06-025J		9,525	26,6	30,8	11,3	6,8	1,50	2,0	17,0	39,3	30,0	1,50
HP 06-030J		9,525	32,9	37,1	11,3	6,8	1,50	2,0	21,0	48,6	35,0	1,80
HP 06-040J		9,525	39,1	43,3	11,3	6,8	1,50	2,0	25,0	57,9	45,0	2,20
HP 06-050J		9,525	51,6	55,8	11,3	6,8	1,50	2,0	33,0	76,4	55,0	2,90
HP 06-065J		9,525	64,2	68,4	11,3	6,8	1,50	2,0	41,0	94,9	70,0	3,60
HP 08-015A		12,700	12,5	21,7	15,2	9,0	1,50	2,5	10,0	27,9	11,5	1,20
HP 08-020A		12,700	17,2	26,3	15,2	9,0	1,50	2,5	13,0	34,1	16,0	1,60
HP 08-025J		12,700	26,6	32,6	15,2	9,0	1,50	2,5	17,0	52,7	30,0	2,00
HP 08-030J		12,700	32,9	38,9	15,2	9,0	1,50	2,5	21,0	65,1	35,0	2,40
HP 08-040J		12,700	39,1	45,1	15,2	9,0	1,50	2,5	25,0	77,5	45,0	2,90
HP 08-050J		12,700	51,6	57,6	15,2	9,0	1,50	2,5	33,0	102,3	55,0	3,80
HP 08-065J		12,700	64,2	70,2	15,2	9,0	1,50	2,5	41,0	127,2	70,0	4,70
HP 08-075J		12,700	76,7	82,7	15,2	9,0	1,50	2,5	49,0	152,0	80,0	5,60
HP 08-100J		12,700	101,7	107,7	15,2	9,0	1,50	2,5	65,0	201,6	105,0	7,50
HP 12-020J		19,050	18,7	25,7	22,5	13,5	2,00	3,5	9,0	55,4	25,0	2,10
HP 12-025J		19,050	27,0	34,0	22,5	13,5	2,00	3,5	13,0	80,1	30,0	3,00
HP 12-035J		19,050	35,4	42,4	22,5	13,5	2,00	3,5	17,0	104,7	40,0	3,90
HP 12-040J		19,050	43,7	50,7	22,5	13,5	2,00	3,5	21,0	129,4	45,0	4,90
HP 12-050J		19,050	52,0	59,0	22,5	13,5	2,00	3,5	25,0	154,0	55,0	5,80
HP 12-065J		19,050	68,6	75,6	22,5	13,5	2,00	3,5	33,0	203,3	70,0	7,60
HP 12-085J		19,050	85,3	92,3	22,5	13,5	2,00	3,5	41,0	252,6	90,0	9,50
HP 12-100J		19,050	101,9	108,9	22,5	13,5	2,00	3,5	49,0	301,9	105,0	11,40
HP 12-125J		19,050	126,9	133,9	22,5	13,5	2,00	3,5	61,0	375,9	130,0	14,10
HP 16-040J		25,400	40,2	48,2	30,0	18,0	3,00	4,0	13,0	152,4	45,0	6,00
HP 16-050J		25,400	52,6	60,6	30,0	18,0	3,00	4,0	17,0	199,4	55,0	7,90
HP 16-065J		25,400	65,0	73,0	30,0	18,0	3,00	4,0	21,0	246,3	70,0	9,70
HP 16-075J		25,400	77,4	85,4	30,0	18,0	3,00	4,0	25,0	293,2	80,0	11,60
HP 16-100J		25,400	102,1	110,1	30,0	18,0	3,00	4,0	33,0	387,0	105,0	15,30
HP 16-125J		25,400	126,9	134,9	30,0	18,0	3,00	4,0	41,0	480,9	130,0	19,00
HP 24-040J		38,100	40,4	52,4	45,0	27,0	3,00	6,0	13,0	236,0	50,0	9,80
HP 24-050J		38,100	52,8	64,8	45,0	27,0	3,00	6,0	17,0	303,4	60,0	11,80
HP 24-065J		38,100	65,2	77,2	45,0	27,0	3,00	6,0	21,0	374,8	75,0	14,60
HP 24-075J		38,100	77,6	89,6	45,0	27,0	3,00	6,0	25,0	446,2	85,0	17,40
HP 24-100J		38,100	102,5	114,5	45,0	27,0	3,00	6,0	33,0	589,0	110,0	22,90
HP 24-125J		38,100	127,3	139,3	45,0	27,0	3,00	6,0	41,0	731,8	135,0	28,50
HP 24-150J		38,100	152,1	164,1	45,0	27,0	3,00	6,0	49,0	874,6	160,0	34,10

* Plates on one pivot pin

Inverted tooth chain sprockets on request.

When ordered by length in metres, the chain will contain the next higher even number of links with a connecting pin. For this type of inverted tooth chain no cranked links are available.



On the following pages, we will only be able to give you a brief overview of the types of chains we can supply since conveyor chains are mostly chains designed for individual applications.

Please send us an enquiry, if you have any queries concerning your specific application.

1. Sprockets for all chains made of steel, cast steel and cast iron, also in split versions and with welded-on segments.

2. Special chains for process engineering equipment of all kind; also made of stainless and heat resistant steel grades.

3. Draw bench chains

- according to DIN 8156 and DIN 8157

4. Conveyor chains / Deep link conveyor chains / Accumulation conveyor chains

- according to DIN 8165 full pin chains and hollow pin chains / type FV
- according to DIN 8165 full pin chains / type M
- according to DIN 8165 hollow pin chains / type MC
- Made to specifications for all applications

5. Moving staircase chains

- according to factory standard and customers' specifications

6. Plate chains for steel plate apron conveyor chains

- according to DIN 8175

7. Plate chains for funiculars

- according to DIN 8176 and DIN Berg 2251

8. Inverted tooth chains according to DIN 8190

- Inverted tooth chains for high speed drives
- Inverted tooth chains made to specifications / Inverted tooth chains for transport

9. Inverted tooth chain sprockets

- according to customers' specifications

10. Rotary-Ketten

11. Galle chains and sprockets

- according to DIN 8150

We will be happy to assist you with all your problems concerning drives and conveyance!

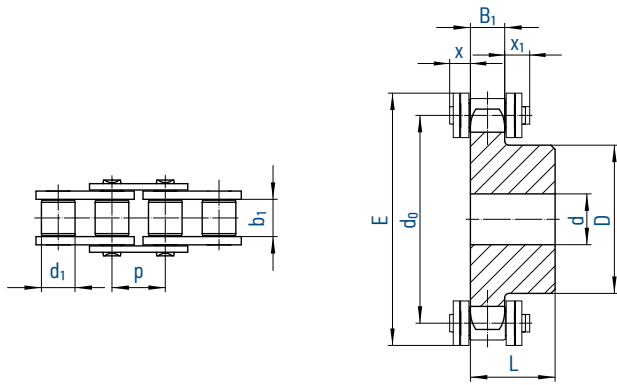

Chain		Pitch	Inner width	Roller Ø	Width over pin	Tooth width	Projection	
ISO		p	b ₁ min.	d ₁ max.	l ₁ max.	B ₁	x max.	x ₁ max.
No.	Ind.	No.	mm	mm	mm	mm	mm	mm
445		04	6,0	2,8	4,0	7,4	2,6	2,5
450		05B-1	8,0	3,0	5,0	8,6	2,8	5,4

Number of teeth	z	445 (04)					450 (05B-1)				
		d ₀	E _{max}	d	D	L	d ₀	E _{max}	d	D	L
	Ind.	mm	mm	mm	mm	mm	mm	mm	mm	mm	mm
10		19,42	25	6	13	10	25,89	34	8	17	12
11		21,30	27	6	14	10	28,40	36	8	18	13
12		23,18	29	6	16	10	30,91	39	8	20	13
13		25,07	31	8	18	10	33,43	41	8	23	13
14		26,96	33	8	20	10	35,95	44	8	25	13
15		28,86	35	8	20	10	38,48	46	8	28	13
16		30,75	36	8	20	13	41,01	49	8	30	14
17		32,65	38	8	20	13	43,54	51	8	30	14
18		34,55	40	8	20	13	46,07	54	8	30	14
19		36,45	42	8	20	13	48,60	57	8	30	14
20		38,36	44	8	20	13	51,14	59	8	30	14
21		40,26	46	8	25	13	53,68	62	8	35	14
22		42,16	48	8	25	13	56,21	64	8	35	14
23		44,06	50	8	25	13	58,75	67	8	35	14
24		45,97	51	8	25	13	61,29	69	8	35	14
25		47,87	53	8	25	13	63,83	72	8	35	14
26		49,78	55	8	30	15	66,37	74	10	40	16
27		51,68	57	8	30	15	68,91	77	10	40	16
28		53,59	59	8	30	15	71,45	79	10	40	16
29		55,49	61	8	30	15	73,99	82	10	40	16
30		57,40	63	8	30	15	76,53	84	10	40	16
32		61,21	67	8	30	15	81,62	90	10	40	16
34		65,03	71	8	30	15	86,70	94	10	40	16
35		66,93	73	8	30	15	89,25	97	10	40	16
36		68,84	75	8	30	15	91,79	100	10	40	16
38		72,66	78	8	30	15	96,88	105	10	40	16
40		76,47	82	8	30	15	101,96	110	10	40	16

* Possibly welded-on hub

Made of steel with a strength of 500 - 600 N/mm². We supply sprockets with custom bore and groove according to specifications. For details on orders and enquiries see page 110. Other sprockets on request.

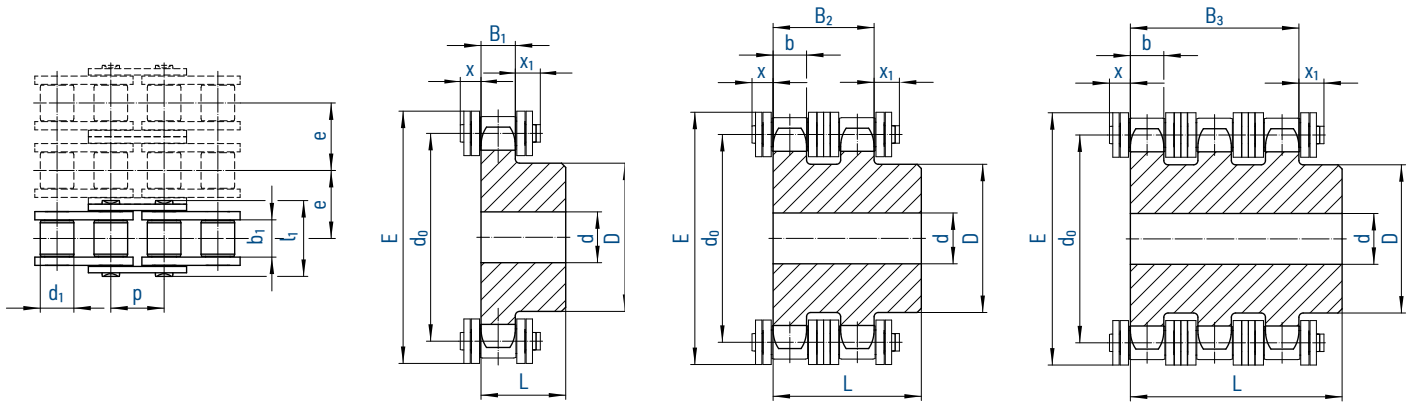

Chain		Pitch	Inner width	Roller Ø	Width over pin	Transverse pitch	Tooth width				Projection		
ISO		p	b ₁ min.	d ₁ max.	l max.	e	B ₁	b	B ₂	B ₃	x max.	x ₁ max.	
No.	Ind.	No.	mm	mm	mm	mm	mm	mm	mm	mm	mm	mm	
455		06B-1	9,525	5,72	6,35	13,5	-	5,3	-	-	-	4,5	7,8
D 455		06B-2	9,525	5,72	6,35	23,8	10,24	-	5,2	15,4	-	4,5	7,8
T 455		06B-3	9,525	5,72	6,35	34,0	10,24	-	5,2	-	25,6	4,5	7,8

Number of teeth	z	Ind.	d ₀	E _{max}	455 (06B-1)			D 455 (06B-2)			T 455 (06B-3)		
					d	D	L	d	D	L	d	D	L
			mm	mm	mm	mm	mm	mm	mm	mm	mm	mm	
10			30,82	40	8	20	22	8	20	22	-	-	-
11			33,81	43	8	22	25	10	22	25	-	-	-
12			36,80	46	8	25	25	10	25	25	-	-	-
13			39,80	49	10	28	25	10	28	25	10	28	35
14			42,81	52	10	31	25	10	31	25	-	-	-
15			45,81	55	10	34	25	10	34	25	12	34	35
16			48,82	58	10	37	28	12	37	30	-	-	-
17			51,84	61	10	40	28	12	40	30	12	40	35
18			54,85	64	10	43	28	12	43	30	-	-	-
19			57,87	67	10	45	28	12	46	30	12	46	35
20			60,89	70	10	46	28	12	49	30	-	-	-
21			63,91	73	12	48	28	12	52	30	14	52	40
22			66,93	76	12	50	28	12	55	30	-	-	-
23			69,95	79	12	52	28	12	58	30	14	58	40
24			72,97	82	12	54	28	12	61	30	-	-	-
25			76,00	85	12	57	28	12	64	30	14	64	40
26			79,02	88	12	60	28	12	67	30	-	-	-
27			82,05	92	12	60	28	12	70	30	14	70	40
28			85,07	95	12	60	28	12	73	30	-	-	-
29			88,10	98	12	60	28	12	76	30	-	-	-
30			91,12	101	12	60	30	12	79	30	14	79	40
31			94,15	104	14	65	30	-	-	-	-	-	-
32			97,18	107	14	65	30	16	80	30	-	-	-
33			100,20	110	14	65	30	-	-	-	-	-	-
34			103,23	113	14	65	30	-	-	-	-	-	-
35			106,26	116	14	65	30	-	-	-	-	-	-
36			109,29	119	16	70	30	-	-	-	-	-	-
37			112,31	122	16	70	30	-	-	-	-	-	-
38			115,34	125	16	70	30	16	90	30	16	90	40
39			118,37	128	16	70	30	-	-	-	-	-	-
40			121,40	131	16	70	30	16	90	30	-	-	-
38	*		115,34	125	19	70	32	19	80	40	-	-	-
45	*		136,55	146	19	70	32	-	-	-	23	90	56
57	*		172,91	182	19	70	32	19	80	40	23	90	56

* Cast iron GG22

Made of steel with a strength of 500 - 600 N/mm². We supply sprockets with custom bore and groove according to specifications. For details on orders and enquiries see page 110. Other sprockets on request.

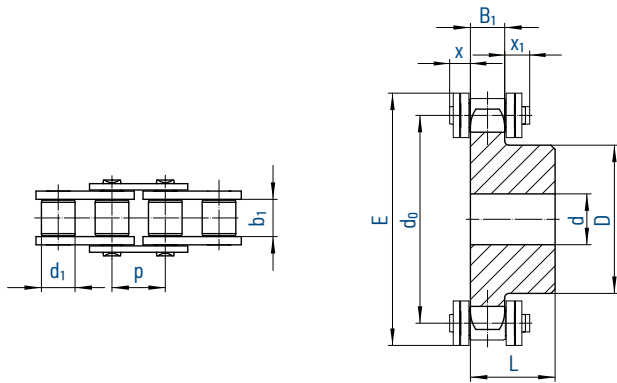

Chain		Pitch	Inner width	Roller Ø	Width over pin	Tooth width	Projection		
ISO		p	b ₁ min.	d ₁ max.	l ₁ max.	B ₁	x max.	x ₁ max.	
No.	Ind.	No.	mm	mm	mm	mm	mm	mm	
331		081	12,7	3,30	7,75	10,2	3,0	3,8	5,3
332		-	12,7	4,88	7,75	11,2	4,5	3,8	5,3

Number of teeth	z	331 (081)					332 / 17 / 18				
		d ₀	E _{max}	d	D	L	d ₀	E _{max}	d	D	L
	Ind.	mm	mm	mm	mm	mm	mm	mm	mm	mm	
10		41,10	51	8	28	14	41,10	51	8	28	14
11		45,08	55	8	31	16	45,08	55	8	31	16
12		49,07	59	8	35	16	49,07	59	8	35	16
13		53,07	63	8	39	16	53,07	63	8	39	16
14		57,07	67	8	43	16	57,07	67	8	43	16
15		61,08	71	8	47	16	61,08	71	8	47	16
16		65,10	75	10	50	18	65,10	75	10	50	18
17		69,12	79	10	50	18	69,12	79	10	50	18
18		73,14	84	10	50	18	73,14	84	10	50	18
19		77,16	88	10	50	18	77,16	88	10	50	18
20		81,18	92	10	50	18	81,18	92	10	50	18
21		85,21	96	12	60	20	85,21	96	12	60	20
22		89,24	100	12	60	20	89,24	100	12	60	20
23		93,27	104	12	60	20	93,27	104	12	60	20
24		97,30	108	12	60	20	97,30	108	12	60	20
25		101,33	112	12	60	20	101,33	112	12	60	20
26		105,36	116	16	70	20	105,36	116	16	70	20
27		109,40	120	16	70	20	109,40	120	16	70	20
28		113,43	124	16	70	20	113,43	124	16	70	20
29		117,46	128	16	70	20	117,46	128	16	70	20
30		121,50	132	16	70	20	121,50	132	16	70	20
34		-	-	-	-	-	137,64	148	16	70	20
36		-	-	-	-	-	145,72	156	16	70	25
38		-	-	-	-	-	153,79	165	16	70	25
40		-	-	-	-	-	161,87	173	16	70	25

Made of steel with a strength of 500 - 600 N/mm². We supply sprockets with custom bore and groove according to specifications. For details on orders and enquiries see page 110. Other sprockets on request.

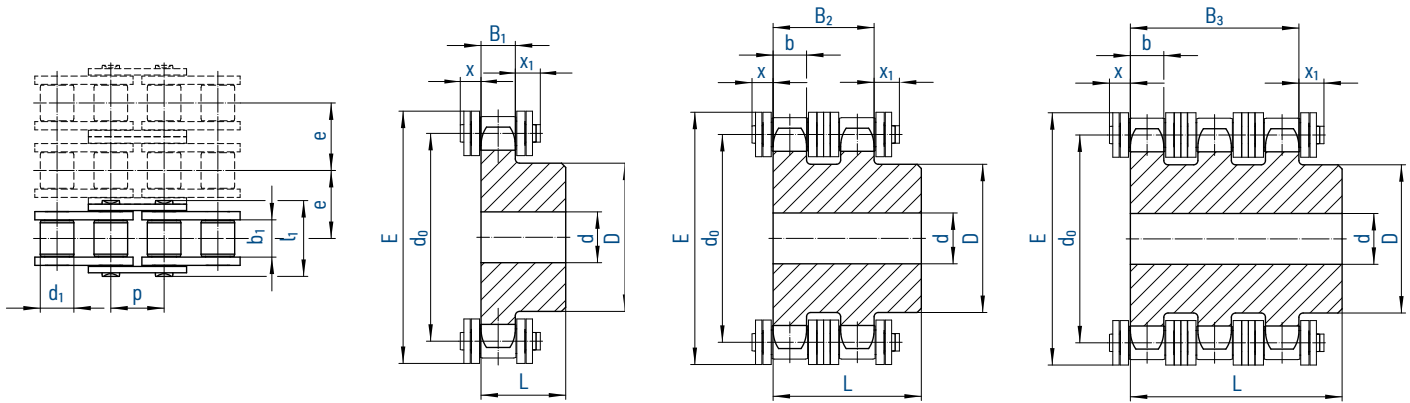

Chain		Pitch	Inner width	Roller Ø	Width over pin	Transverse pitch	Tooth width				Projection		
ISO	p	b_1 min.	d_1 max.	l max.	e	B_1	b	B_2	B_3	x max.	x_1 max.		
No.	Ind.	No.	mm	mm	mm	mm	mm	mm	mm	mm	mm		
462		08 B-1	12,7	7,75	8,51	17,0	-	7,2	-	-	-	5,4	9,3
D 462		08 B-2	12,7	7,75	8,51	31,0	13,92	-	7,0	21,0	-	5,4	9,3
T 462		08 B-3	12,7	7,75	8,51	44,9	13,92	-	7,0	-	34,9	5,4	9,3

Number of teeth	z	Ind.	d_0	E_{max}	462 (08B-1)			D 462 (08B-2)			T 462 (08B-3)		
					d	D	L	d	D	L	d	D	L
			mm	mm	mm	mm	mm	mm	mm	mm	mm	mm	mm
10			41,10	54	10	26	25	10	28	32	-	-	-
11			45,08	58	10	29	25	12	32	35	-	-	-
12			49,07	62	10	33	28	12	35	35	-	-	-
13			53,07	66	10	37	28	12	38	35	14	38	50
14			57,07	70	10	41	28	12	42	35	-	-	-
15			61,08	74	10	45	28	12	46	35	14	46	50
16			65,10	78	12	50	28	14	50	35	-	-	-
17			69,12	82	12	52	28	14	54	35	16	54	50
18			73,14	86	12	56	28	14	58	35	-	-	-
19			77,16	90	12	60	28	14	62	35	16	62	50
20			81,18	94	12	64	28	14	66	35	-	-	-
21			85,21	98	12	68	28	16	70	40	20	70	55
22			89,24	102	12	70	28	16	70	40	-	-	-
23			93,27	106	14	70	28	16	70	40	20	70	55
24			97,30	110	14	70	28	16	75	40	-	-	-
25			101,33	114	14	70	28	16	80	40	20	80	55
26			105,36	118	16	70	30	20	85	40	-	-	-
27			109,40	122	16	70	30	20	85	40	20	85	55
28			113,43	126	16	70	30	20	90	40	-	-	-
29			117,46	130	16	80	30	20	95	40	-	-	-
30			121,50	134	16	80	30	20	100	40	20	100	55
31			125,53	138	16	90	30	-	-	-	-	-	-
32			129,57	142	16	90	30	20	100	40	-	-	-
33			133,61	146	16	90	30	-	-	-	-	-	-
34			137,64	150	16	90	30	-	-	-	-	-	-
35			141,68	154	16	90	30	20	100	40	-	-	-
36			145,72	158	16	90	35	20	110	40	-	-	-
37			149,75	162	16	90	35	-	-	-	-	-	-
38			153,79	166	16	90	35	20	110	40	25	120	55
39			157,83	170	16	90	35	-	-	-	-	-	-
40			161,87	174	16	90	35	20	110	40	-	-	-
38	*		153,79	166	-	-	-	23	90	50	23	100	60
45	*		182,06	195	19	70	40	-	-	-	-	-	-
57	*		230,54	243	19	70	40	23	90	50	23	100	60

* Cast iron GG22

Made of steel with a strength of 500 - 600 N/mm². We supply sprockets with custom bore and groove according to specifications. For details on orders and enquiries see page 110. Other sprockets on request.

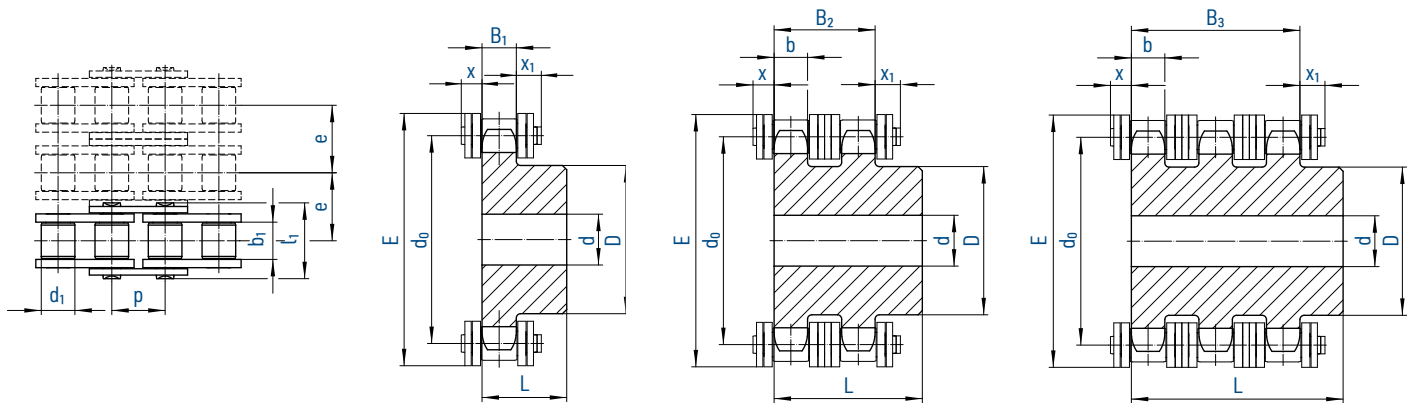

Chain		Pitch	Inner width	Roller Ø	Width over pin	Transverse pitch	Tooth width				Projection		
ISO	p	b ₁ min.	d ₁ max.	l max.	e	B ₁	b	B ₂	B ₃	x max.	x ₁ max.		
No.	Ind.	No.	mm	mm	mm	mm	mm	mm	mm	mm	mm	mm	
501		10 B-1	15,875	9,65	10,16	19,6	-	9,1	-	-	-	5,6	9,7
D 501		10 B-2	15,875	9,65	10,16	36,2	16,59	-	9,0	25,5	-	5,6	9,7
T 501		10 B-3	15,875	9,65	10,16	52,8	16,59	-	9,0	-	42,1	5,6	9,7

Number of teeth	z	Ind.	d ₀	E _{max}	501 (10B-1)			D 501 (10B-2)			T 501 (10B-3)		
					d	D	L	d	D	L	d	D	L
			mm	mm	mm	mm	mm	mm	mm	mm	mm	mm	
10			51,37	68	10	35	25	12	35	40	-	-	-
11			56,35	72	12	37	30	14	39	40	-	-	-
12			61,34	77	12	42	30	14	44	40	-	-	-
13			66,34	82	12	47	30	14	49	40	16	49	55
14			71,34	87	12	52	30	14	54	40	-	-	-
15			76,35	92	12	57	30	14	59	40	16	59	55
16			81,37	97	12	60	30	16	64	45	-	-	-
17			86,39	102	12	60	30	16	69	45	16	69	60
18			91,42	107	14	70	30	16	74	45	-	-	-
19			96,45	112	14	70	30	16	79	45	16	79	60
20			101,48	117	14	75	30	16	84	45	-	-	-
21			106,51	122	16	75	30	16	85	45	20	85	60
22			111,55	127	16	80	30	16	90	45	-	-	-
23			116,59	132	16	80	30	16	95	45	20	95	60
24			121,62	137	16	80	30	16	100	45	-	-	-
25			126,66	142	16	80	30	16	105	45	20	105	60
26			131,70	147	20	85	35	20	110	45	-	-	-
27			136,74	152	20	85	35	20	110	45	20	110	60
28			141,79	157	20	90	35	20	115	45	-	-	-
29			146,83	162	20	90	35	20	115	45	-	-	-
30			151,87	167	20	90	35	20	120	45	20	120	60
31			156,92	173	20	95	35	-	-	-	-	-	-
32			161,96	178	20	95	35	20	120	45	-	-	-
33			167,01	183	20	95	35	-	-	-	-	-	-
34			172,05	188	20	95	35	-	-	-	-	-	-
35			177,10	193	20	95	35	-	-	-	-	-	-
36			182,14	198	20	100	35	-	-	-	-	-	-
37			187,19	203	20	100	35	-	-	-	-	-	-
38			192,24	208	20	100	35	20	120	45	25	120	60
39			197,29	213	20	100	35	-	-	-	-	-	-
40			202,35	218	20	100	35	20	120	45	-	-	-
38	*		192,24	208	-	-	-	29	100	50	31	100	60
45	*		227,58	243	19	80	40	-	-	-	-	-	-
57	*		288,18	304	23	90	45	29	100	56	31	100	63

* Cast iron GG22

Made of steel with a strength of 500 - 600 N/mm². We supply sprockets with custom bore and groove according to specifications. For details on orders and enquiries see page 110. Other sprockets on request.

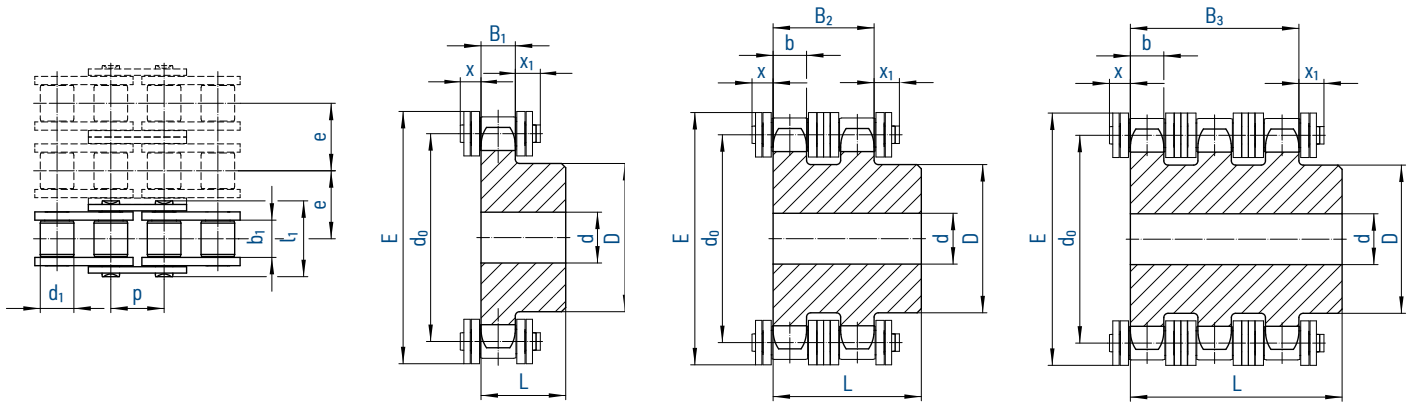

Chain		Pitch	Inner width	Roller Ø	Width over pin	Transverse pitch	Tooth width				Projection		
No.	Ind.	ISO	p	b ₁ min.	d ₁ max.	l max.	e	B ₁	b	B ₂	B ₃	x max.	x ₁ max.
		No.	mm	mm	mm	mm	mm	mm	mm	mm	mm	mm	mm
513		12 B-1	19,05	11,68	12,07	22,7	-	11,1	-	-	-	6,4	11,0
D 513		12 B-2	19,05	11,68	12,07	42,2	19,46	-	10,8	30,3	-	6,4	11,0
T 513		12 B-3	19,05	11,68	12,07	61,7	19,46	-	10,8	-	49,8	6,4	11,0

Number of teeth		513 (12 B-1)					D 513 (12 B-2)			T 513 (12 B-3)		
z		d ₀	E _{max}	d	D	L	d	D	L	d	D	L
	Ind.	mm	mm	mm	mm	mm	mm	mm	mm	mm	mm	mm
10		61,65	79	12	42	30	12	42	45	-	-	-
11		67,62	85	14	46	35	16	47	50	-	-	-
12		73,6	91	14	52	35	16	53	50	-	-	-
13		79,6	97	14	58	35	16	59	50	20	59	70
14		85,61	103	14	64	35	16	65	50	-	-	-
15		91,62	109	14	70	35	16	71	50	20	71	70
16		97,65	115	16	75	35	20	77	50	-	-	-
17		103,67	121	16	80	35	20	83	50	20	83	70
18		109,71	127	16	80	35	20	89	50	-	-	-
19		115,74	133	16	80	35	20	95	50	20	95	70
20		121,78	139	16	80	35	20	100	50	-	-	-
21		127,82	145	20	90	40	20	100	50	20	100	70
22		133,86	151	20	90	40	20	100	50	-	-	-
23		139,9	157	20	90	40	20	110	50	20	110	70
24		145,95	163	20	90	40	20	110	50	-	-	-
25		151,99	169	20	90	40	20	120	50	20	120	70
26		158,04	176	20	95	40	20	120	50	-	-	-
27		164,09	182	20	95	40	20	120	50	-	-	-
28		170,14	188	20	95	40	20	120	50	-	-	-
29		176,2	194	20	95	40	20	120	50	-	-	-
30		182,25	200	20	95	40	20	120	50	20	120	70
31		188,3	206	20	100	40	-	-	-	-	-	-
32		194,35	212	20	100	40	-	-	-	-	-	-
33		200,41	218	20	100	40	-	-	-	-	-	-
34		206,46	224	20	100	40	-	-	-	-	-	-
35		212,52	230	20	100	40	-	-	-	-	-	-
36		218,57	236	20	100	40	-	-	-	-	-	-
37		224,63	242	20	100	40	-	-	-	-	-	-
38		230,69	248	20	100	40	25	120	50	25	130	70
39		236,74	254	20	100	40	-	-	-	25	130	70
40		242,8	260	20	100	40	25	120	50	-	-	-
38	*	230,69	248	23	100	40	29	130	63	30	140	70
45	*	273,09	290	23	100	56	29	130	63	30	140	70
57	*	345,81	363	29	100	56	29	130	63	39	140	70

* Cast iron GG22

Made of steel with a strength of 500 - 600 N/mm². We supply sprockets with custom bore and groove according to specifications. For details on orders and enquiries see page 110. Other sprockets on request.

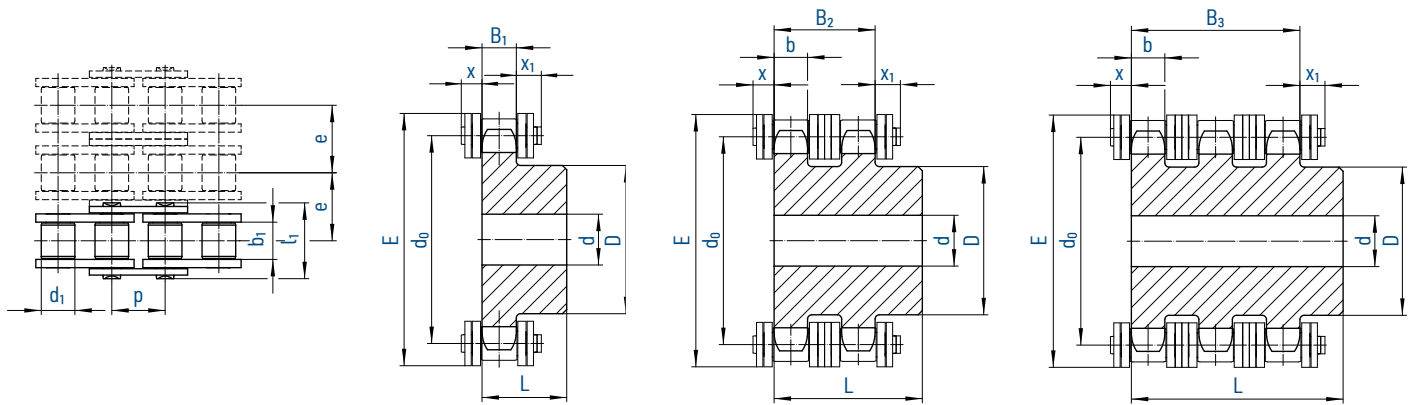

Chain		Pitch	Inner width	Roller Ø	Width over pin	Transverse pitch	Tooth width				Projection		
No.	Ind.	ISO	p	b ₁ min.	d ₁ max.	l max.	e	B ₁	b	B ₂	B ₃	x max.	x ₁ max.
		No.	mm	mm	mm	mm	mm	mm	mm	mm	mm	mm	mm
548		16 B-1	25,4	17,02	15,88	36,1	-	16,2	-	-	-	10,8	16,2
D 548		16 B-2	25,4	17,02	15,88	68,0	31,88	-	15,8	47,7	-	10,8	16,2
T 548		16 B-3	25,4	17,02	15,88	99,9	31,88	-	15,8	-	79,6	10,8	16,2

Number of teeth	z	Ind.	d ₀	E _{max}	548 (16 B-1)			D 548 (16 B-2)			T 548 (16 B-3)		
					d	D	L	d	D	L	d	D	L
			mm	mm	mm	mm	mm	mm	mm	mm	mm	mm	
10			82,2	104	16	55	35	16	56	65	-	-	-
11			90,16	112	16	61	40	20	64	70	25	64	100
12			98,14	120	16	69	40	20	72	70	-	-	-
13			106,14	128	16	78	40	20	80	70	25	80	100
14			114,15	136	16	84	40	20	88	70	-	-	-
15			122,17	144	16	92	40	20	96	70	25	96	100
16			130,2	152	20	100	45	20	104	70	-	-	-
17			138,23	160	20	100	45	20	112	70	30	112	100
18			146,27	168	20	100	45	20	120	70	-	-	-
19			154,32	176	20	100	45	20	128	70	30	128	100
20			162,37	184	20	100	45	20	130	70	-	-	-
21			170,42	192	20	110	50	25	130	70	30	130	100
22			178,48	200	20	110	50	25	130	70	-	-	-
23			186,54	208	20	110	50	25	130	70	30	130	100
24			194,6	216	20	110	50	25	130	70	-	-	-
25			202,66	224	20	110	50	25	130	70	30	130	100
26			210,72	232	20	120	50	25	130	70	-	-	-
27			218,79	240	20	120	50	25	130	70	-	-	-
28			226,86	248	20	120	50	25	130	70	-	-	-
29			234,93	256	20	120	50	25	130	70	-	-	-
30			243	265	20	120	50	25	130	70	30	130	100
32			259,14	281	25	120	50	-	-	-	-	-	-
34			275,29	297	25	120	50	-	-	-	-	-	-
35			283,36	305	25	120	50	-	-	-	-	-	-
36			291,43	313	25	120	50	-	-	-	-	-	-
38			307,58	329	25	120	50	25	140	70	30	140	100
40			323,74	345	25	120	50	25	140	70	-	-	-
45	*		364,12	386	29	125	70	-	-	-	-	-	-
57	*		461,08	483	34	125	70	39	160	90	44	165	100

* Cast iron GG22

Made of steel with a strength of 500 - 600 N/mm². We supply sprockets with custom bore and groove according to specifications. For details on orders and enquiries see page 110. Other sprockets on request.

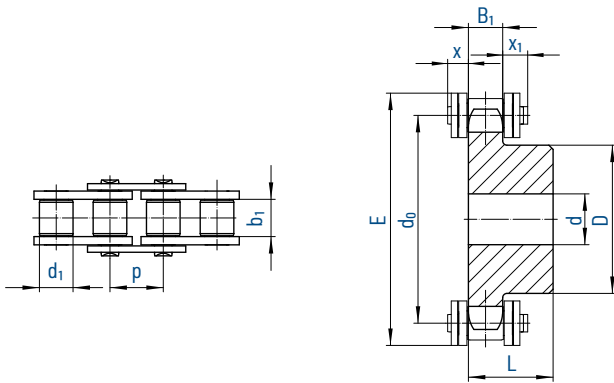

Chain		Pitch	Inner width	Roller Ø	Width over pin	Tooth width	Projection	
ISO		p	b ₁ min.	d ₁ max.	l ₁ max.	B ₁	x max.	x ₁ max.
No.	Ind.	No.	mm	mm	mm	mm	mm	mm
563		20 B-1	31,75	19,56	19,05	43,2	18,5	12,8
596		24 B-1	38,10	25,40	25,40	53,4	24,1	16,0

Number of teeth	563 (20 B-1)						596 (24 B-1)				
	z	d ₀	E _{max}	d	D	L	d ₀	E _{max}	d	D	L
	Ind.	mm	mm	mm	mm	mm	mm	mm	mm	mm	mm
10		102,75	130	20	70	40	123,30	157	20	80	45
11		112,69	139	20	77	45	135,23	169	25	90	50
12		122,67	149	20	88	45	147,21	181	25	102	50
13		132,67	159	20	98	45	159,21	193	25	114	50
14		142,68	169	20	108	45	171,22	205	25	128	50
15		152,71	179	20	118	45	183,25	217	25	140	50
16		162,74	190	25	120	50	195,29	229	25	140	55
17		172,79	200	25	120	50	207,35	241	25	140 *	55
18		182,84	210	25	120	50	219,41	253	25	140 *	55
19		192,90	220	25	120 *	50	231,48	265	25	140 *	55
20		202,96	230	25	120 *	50	243,55	277	25	140 *	55
21		213,03	240	25	140 *	55	255,63	289	25	150 *	60
22		223,10	250	25	140 *	55	267,72	302	25	150 *	60
23		233,17	260	25	140 *	55	279,81	314	25	150 *	60
24		243,25	270	25	140 *	55	291,90	326	25	150 *	60
25		253,32	280	25	140 *	55	303,99	338	25	150 *	60

* Possibly welded-on hub

Made of steel with a strength of 500 - 600 N/mm². We supply sprockets with custom bore and groove according to specifications. For details on orders and enquiries see page 110. Other sprockets on request.

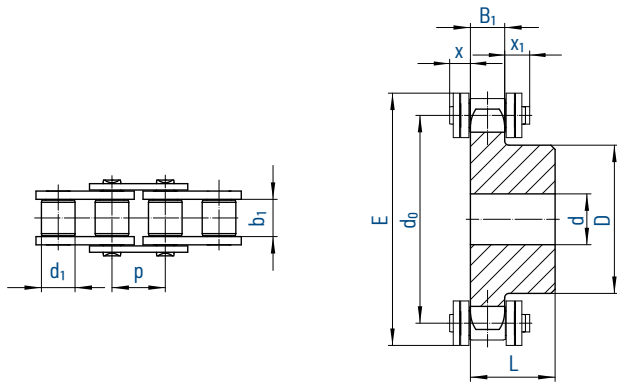

Chain		Pitch	Inner width	Roller Ø	Width over pin	Tooth width	Projection	
⚙		p	b ₁ min.	d ₁ max.	l ₁ max.	B ₁	x max.	x ₁ max.
No.	Ind.	mm	mm	mm	mm	mm	mm	mm
455 RF		9,525	5,72	6,35	13,5	5,3	4,5	7,8
462 RF		12,700	7,75	8,51	17,0	7,2	5,4	9,3
501 RF		15,875	9,65	10,16	19,6	9,1	5,6	9,7
513 RF		19,050	11,68	12,07	22,7	11,1	6,4	11,0
548 RF		25,400	17,02	15,88	36,1	16,2	10,8	16,2

Number of teeth		455 RF					462 RF					501 RF				
		d ₀	E _{max}	d	D	L	d ₀	E _{max}	d	D	L	d ₀	E _{max}	d	D	L
z	Ind.	mm	mm	mm	mm	mm	mm	mm	mm	mm	mm	mm	mm	mm	mm	mm
13		39,79	49	10	28	25	53,06	66	10	37	28	66,32	82	12	47	30
15		45,81	55	10	34	25	61,09	74	10	45	28	76,36	92	12	57	30
17		51,83	61	10	40	28	69,11	82	12	52	28	86,39	102	14	60	30
19		57,87	67	10	45	28	77,16	90	12	60	28	96,45	112	14	70	30
21		63,91	73	12	48	28	85,22	98	14	68	28	106,52	122	16	80	30
23		69,65	79	12	52	28	93,27	106	14	70	28	116,58	132	16	80	30
25		76,00	85	12	57	28	101,33	114	14	70	28	126,66	142	16	80	30

Number of teeth		513 RF					548 RF				
		d ₀	E _{max}	d	D	L	d ₀	E _{max}	d	D	L
z	Ind.	mm	mm	mm	mm	mm	mm	mm	mm	mm	
13		79,59	97	14	58	35	106,12	128	16	78	40
15		91,63	109	14	70	35	122,17	144	16	92	40
17		103,67	121	16	80	35	138,22	160	20	100	45
19		115,75	133	16	80	35	154,33	176	20	100	45
21		127,82	145	20	90	40	170,43	192	20	110	50
23		139,90	157	20	90	40	186,54	208	20	110	50
25		152,00	169	20	90	40	202,66	224	20	110	50

Other sprockets made of stainless steel or plastic are available on request.

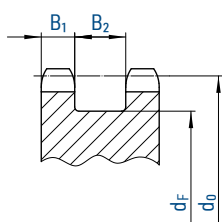

Chain			Pitch	Inner width	Roller Ø
	B ₁	B ₂	p	b ₁ min.	d ₁ max.
No.	mm	mm	mm	mm	mm
513 SF	10,6	42	19,05	11,68	12
513 SFK	10,6	42	19,05	11,68	12
513 SFV	10,6	42	19,05	11,68	12

Number of teeth	PCD	Pilot bore Ø	Hub-Ø between sprockets
z	d ₀		d _F
	mm	mm	mm
15+15	91,62	20	61
17+17	103,67	20	73
19+19	115,73	20	85

Other sprockets made of stainless steel or plastic are available on request.

Sprockets
for hollow pin chains 01650

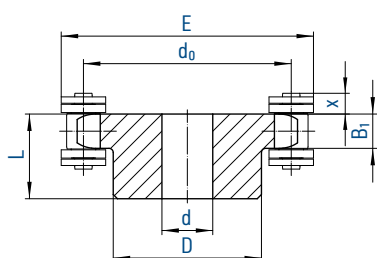

Chain	Pitch	Inner width	Roller Ø	Hollow pin Ø	Width over hollow pin	Plate height	Number of teeth	Sprocket dimensions						
								B ₁	d ₀	d	D	L	E	x
	p	b ₁ min.	d ₁ max.	d ₁ max.	d ₁ max.	g max.	z	mm	mm	mm	mm	mm	mm	mm
No.	mm	mm	mm	mm	mm	mm		mm	mm	mm	mm	mm	mm	mm
01650	50,8	10	30	8,2	27	26	7	9	117,08	20	80	40	148	10
01650	50,8	10	30	8,2	27	26	12	9	196,28	30	110	50	227	10
01650	50,8	10	30	8,2	27	26	15	9	244,33	30	120	50	275	10
01650	50,8	10	30	8,2	27	26	18	9	292,55	30	140	50	323	10

We supply sprockets with custom bore and groove according to specifications.

SPR tensioning wheels
with integrated ball bearing

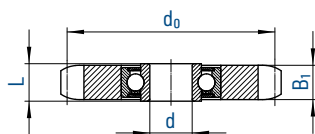

Chain	Pitch	Inner width	Roller Ø	Width over pin	Jockey sprocket	Number of teeth	d ₀	B ₁	Bearing		Load ratings		
									d +0,3 +0,1	L	C	C ₀	
	ISO	p	b ₁ min.	d ₁ max.	L max.	z	mm	mm	mm	mm	kN	kN	
No.	No.	mm inch	mm	mm	mm	No.	mm	mm	mm	mm	dyn.	stat.	
455	06B-1	9,525 3/8	5,72	6,35	13,5	SPR 455	21	63,91	5,3	16	18,3	7,5	4,5
331	081	12,700 1/2	3,30	7,75	10,2	SPR 331	18	73,14	3,0	16	18,3	7,5	4,5
332	-	12,700 1/2	4,88	7,75	11,2	SPR 332	18	73,14	4,5	16	18,3	7,5	4,5
462	08B-1	12,700 1/2	7,75	8,51	17,0	SPR 462	18	73,14	7,2	16	18,3	7,5	4,5
501	10B-1	15,875 5/8	9,65	10,16	19,6	SPR 501	17	86,39	9,1	16	18,3	7,5	4,5
513	12B-1	19,050 3/4	11,68	12,07	22,7	SPR 513	15	91,62	11,1	16	18,3	7,5	4,5
548	16B-1	25,400 1	17,02	15,88	36,1	SPR 548	12	98,14	16,2	20	17,7	10,1	6,3
563	20B-1	31,750 1 1/4	19,56	19,05	43,2	SPR 563	13	132,67	18,5	25	21,0	11,0	7,1

Made of steel with a strength of 500 - 600 N/mm². Not suitable as guide gear.

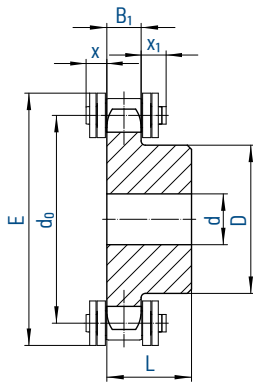

Formula for calculating the PCD:

$$d_0 = \frac{p}{\sin(180^\circ/z)} = pn$$

Formula for calculating the permissible torque:

$$M_{zul.} = \frac{F_B [N] \cdot \frac{d_0 [mm]}{2}}{10 \cdot 1000} [Nm]$$

In all cases where the chain does not wrap around the sprocket, but only contacts it tangentially, the sprocket must be a lantern gear version, because only one tooth at a time meshes with the chain. Therefore the teeth of the sprocket are tempered to reduce wear. Thus roller chains are frequently used as a rack and pinion arrangement.

Rack and pinion arrangements with chains are inexpensive and easy to assemble. A spring clip connecting link or a connecting link with cottered pin is attached to both ends of a pre-stretched chain with an uneven number of links. By means of the connecting links the chain is then mounted to a clamping device. The chain must be supported over the whole length.

Lantern gear	Number of teeth	PCD	Tip circle Ø	Tooth width	Pre-drilled bore	Hub		Roller chain	Pitch	Inner width	Roller Ø
						Ø	length				
⚙️	z	d ₀	d _k max.	B ₁	d	D	L	⚙️	p	b ₁ min.	d ₁ max.
No.		mm	mm	mm	mm	mm	mm		mm	mm	mm
TRB 15462	15	61,08	69,1	6,3	10	30,5	25	462	12,700	7,75	8,51
TRB 17462	17	69,12	77,2	6,3	12	38,5	25	462	12,700	7,75	8,51
TRB 19462	19	77,16	85,3	6,3	12	46,5	25	462	12,700	7,75	8,51
TRB 21462	21	85,21	93,4	6,3	16	54,5	25	462	12,700	7,75	8,51
TRB 23462	23	93,27	101,4	6,3	16	63,0	25	462	12,700	7,75	8,51
TRB 15501	15	76,35	85,9	8,0	12	45,5	25	501	15,875	9,65	10,16
TRB 17501	17	86,39	96,0	8,0	16	55,5	25	501	15,875	9,65	10,16
TRB 19501	19	96,45	106,1	8,0	16	66,0	25	501	15,875	9,65	10,16
TRB 21501	21	106,51	116,2	8,0	16	76,0	25	501	15,875	9,65	10,16
TRB 23501	23	116,59	126,3	8,0	16	86,0	25	501	15,875	9,65	10,16
TRB 15513	15	91,63	103,0	9,5	16	45,0	35	513	19,050	11,68	12,07
TRB 17513	17	103,67	115,1	9,5	20	57,0	35	513	19,050	11,68	12,07
TRB 19513	19	115,74	127,3	9,5	20	69,0	35	513	19,050	11,68	12,07
TRB 21513	21	127,82	139,4	9,5	20	81,0	35	513	19,050	11,68	12,07
TRB 23513	23	139,90	151,5	9,5	20	93,0	35	513	19,050	11,68	12,07
TRB 15548	15	122,17	137,1	14,0	20	75,0	40	548	25,400	17,02	15,88
TRB 17548	17	138,23	153,3	14,0	20	91,0	40	548	25,400	17,02	15,88
TRB 19548	19	154,32	169,5	14,0	20	107,0	40	548	25,400	17,02	15,88
TRB 21548	21	170,42	185,6	14,0	25	123,0	40	548	25,400	17,02	15,88
TRB 23548	23	186,54	201,8	14,0	25	140,0	40	548	25,400	17,02	15,88

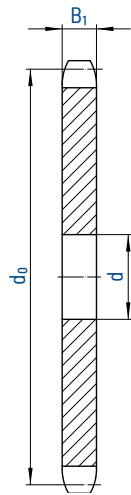

made of steel

Plate thickness = 4 mm
 445 (04) as of z = 51
 450 (05 B-1) as of z = 46

Number of teeth	445 (04)		450 (05 B-1)		455 (06 B-1)	
	p = 6,0 mm	b ₁ = 2,8 mm	p = 8,0 mm	b ₁ = 3,0 mm	p = 9,525 mm	b ₁ = 5,720 mm
z	d ₁ = 4,0 mm	B ₁ = 2,6 mm	d ₁ = 5,0 mm	B ₁ = 2,8 mm	d ₁ = 6,350 mm	B ₁ = 5,300 mm
	d ₀	d	d ₀	d	d ₀	d
Ind.	mm	mm	mm	mm	mm	mm
11	21,30	6	28,40	8	33,81	8
12	23,18	6	30,91	8	36,80	8
13	25,07	8	33,43	8	39,80	8
14	26,96	8	35,95	8	42,81	8
15	28,86	8	38,48	8	45,81	8
16	30,75	8	41,01	8	48,82	10
17	32,65	8	43,54	8	51,84	10
18	34,55	8	46,07	8	54,85	10
19	36,45	8	48,60	8	57,87	10
20	38,36	8	51,14	8	60,89	10
21	40,26	8	53,68	8	63,91	10
22	42,16	8	56,21	8	66,93	10
23	44,06	8	58,75	8	69,95	10
24	45,97	8	61,29	8	72,97	10
25	47,87	8	63,83	8	76,00	10
26	49,78	8	66,37	10	79,02	10
27	51,68	8	68,91	10	82,05	10
28	53,59	8	71,45	10	85,07	10
29	-	-	73,99	10	88,10	10
30	57,40	8	76,53	10	91,12	10
31	-	-	79,08	10	94,15	12
32	61,21	8	81,62	10	97,18	12
33	63,12	8	84,16	10	100,20	12
34	65,03	8	86,70	10	103,23	12
35	66,93	8	89,25	10	106,26	12
36	68,84	8	91,79	10	109,29	12
37	70,75	8	94,33	10	112,31	12
38	72,65	8	96,88	10	115,34	12
39	-	-	99,42	10	118,37	12
40	76,47	8	101,96	10	121,40	12
45	86,01	10	114,68	12	136,55	16
57	108,92	12	145,22	14	172,91	16
65	124,19	14	165,59	16	197,15	20

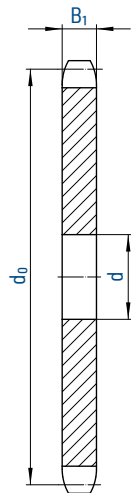

made of steel

Plate thickness = 4 mm
331 (081) as of z = 41

Number of teeth	331 (081)		332		462 (08 B-1)		501 (10 B-1)		
	p = 12,70 mm	b ₁ = 3,30 mm	p = 12,70 mm	b ₁ = 4,88 mm	p = 12,70 mm	b ₁ = 7,75 mm	p = 15,875 mm	b ₁ = 9,650 mm	
	d ₁ = 7,75 mm	B ₁ = 3,00 mm	d ₁ = 7,75 mm	B ₁ = 4,50 mm	d ₁ = 8,51 mm	B ₁ = 7,20 mm	d ₁ = 10,160 mm	B ₁ = 9,100 mm	
z	d ₀	d	d ₀	d	d ₀	d	d ₀	d	
	Ind.	mm	mm	mm	mm	mm	mm	mm	
11		45,08	8	45,08	8	45,08	10	56,35	10
12		49,07	8	49,07	8	49,07	10	61,34	10
13		53,07	8	53,07	8	53,07	10	66,34	10
14		57,07	8	57,07	8	57,07	10	71,34	10
15		61,08	8	61,08	8	61,08	10	76,35	10
16		65,10	10	65,10	10	65,10	10	81,37	12
17		69,12	10	69,12	10	69,12	10	86,39	12
18		73,14	10	73,14	10	73,14	10	91,42	12
19		77,16	10	77,16	10	77,16	10	96,45	12
20		81,18	10	81,18	10	81,18	10	101,48	12
21		85,21	10	85,21	10	85,21	12	106,51	12
22		89,24	10	89,24	10	89,24	12	111,55	12
23		93,27	10	93,27	10	93,27	12	116,59	12
24		97,30	10	97,30	10	97,30	12	121,62	12
25		101,33	10	101,33	10	101,33	12	126,66	12
26		105,36	12	105,36	12	105,36	16	131,70	16
27		109,40	12	109,40	12	109,40	16	136,74	16
28		113,43	12	113,43	12	113,43	16	141,79	16
29		-	-	117,46	12	117,46	16	146,83	16
30		121,50	12	121,50	12	121,50	16	151,87	16
31		-	-	125,53	12	125,53	16	156,92	16
32		129,57	12	129,57	12	129,57	16	161,96	16
33		133,61	12	133,61	12	133,61	16	167,01	16
34		137,64	12	137,64	12	137,64	16	172,05	16
35		141,68	12	141,68	12	141,68	16	177,10	16
36		145,72	16	145,72	16	145,72	16	182,14	20
37		149,75	16	149,75	16	149,75	16	187,19	20
38		153,79	16	153,79	16	153,79	16	192,24	20
39		157,83	16	157,83	16	157,83	16	197,29	20
40		161,87	16	161,87	16	161,87	16	202,35	20
45		182,06	16	182,06	16	182,06	20	227,58	20
57		230,54	20	230,54	20	-	-	288,18	25
65		-	-	262,87	20	262,87	25	328,58	25

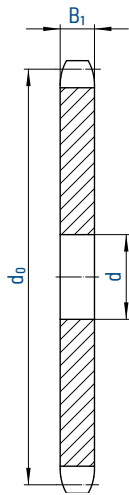

made of steel

Number of teeth <i>z</i>	513 (12 B-1)		548 (16 B-1)		563 (20 B-1)		596 (24 B-1)		
	<i>p</i> = 19,05 mm <i>b</i> ₁ = 11,68 mm <i>d</i> ₁ = 12,07 mm <i>B</i> ₁ = 11,10 mm		<i>p</i> = 25,40 mm <i>b</i> ₁ = 17,02 mm <i>d</i> ₁ = 15,88 mm <i>B</i> ₁ = 16,20 mm		<i>p</i> = 31,75 mm <i>b</i> ₁ = 19,56 mm <i>d</i> ₁ = 19,05 mm <i>B</i> ₁ = 18,50 mm		<i>p</i> = 38,10 mm <i>b</i> ₁ = 25,40 mm <i>d</i> ₁ = 25,40 mm <i>B</i> ₁ = 24,10 mm		
	<i>d</i> ₀	<i>d</i>	<i>d</i> ₀	<i>d</i>	<i>d</i> ₀	<i>d</i>	<i>d</i> ₀	<i>d</i>	
	Ind.	mm	mm	mm	mm	mm	mm	mm	
11		67,62	14	90,16	15	112,69	20	135,23	20
12		73,60	14	98,14	15	122,67	20	147,21	20
13		79,60	14	106,14	15	132,67	20	159,21	20
14		85,61	14	114,15	15	142,68	20	171,22	20
15		91,62	14	122,17	15	152,71	20	183,25	20
16		97,65	14	130,20	19	162,74	20	195,29	25
17		103,67	14	138,23	19	172,79	20	207,35	25
18		109,71	14	146,27	19	182,84	20	219,41	25
19		115,74	14	154,32	19	192,90	20	231,48	25
20		121,78	14	162,37	19	202,96	20	243,55	25
21		127,82	16	170,42	20	213,03	25	255,63	25
22		133,86	16	178,48	20	223,10	25	267,72	25
23		139,90	16	186,54	20	233,17	25	279,81	25
24		145,95	16	194,60	20	243,25	25	291,90	25
25		151,99	16	202,66	20	253,32	25	303,99	25
26		158,04	16	210,72	20	263,40	25	-	-
27		164,09	16	218,79	20	273,49	25	328,19	30
28		170,14	16	226,86	20	283,57	25	-	-
29		176,20	16	234,93	20	293,66	25	352,39	30
30		182,25	16	243,00	20	303,75	25	364,50	30
31		188,30	20	251,07	25	313,83	25	-	-
32		194,35	20	259,14	25	323,92	25	388,71	30
33		200,41	20	267,21	25	334,01	25	-	-
34		206,46	20	275,29	25	344,11	25	-	-
35		212,52	20	283,36	25	354,20	25	425,04	30
36		218,57	20	291,43	25	364,29	25	-	-
37		224,63	20	299,51	25	374,38	25	-	-
38		230,69	20	307,58	25	384,48	25	461,38	30
39		236,74	20	315,66	25	394,57	25	-	-
40		242,80	20	323,74	25	404,67	25	485,60	30
45		273,09	25	364,12	25	455,16	30	546,19	30
57		345,81	25	461,08	30	576,35	30	691,63	30
65		394,30	25	525,73	30	657,17	30	788,60	40

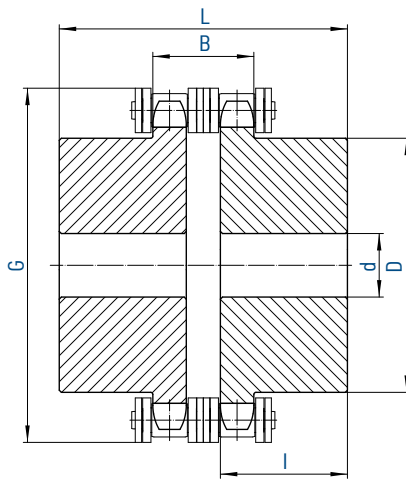
Advantages:

- Elastic torque transmission
- Fast decoupling by simply slackening the chain
- Especially inexpensive

Example:

A 4-cylinder diesel engine with $P = 110 \text{ kW}$ and $n = 1400 \text{ rpm}$ is to be coupled to a three-phase alternator - dynamic load factor 1,5.

The calculation is as follows:

$$1,5 \frac{P}{n} = 1,5 \frac{110}{1400} = 0,1178$$

Select the coupling according to $\frac{P}{n}$ column (see below):

The coupling next in size is No. 548 18.

Dynamic load factors

Load type of driven machines	Drive machines		
	Electric motors	Internal combustion engines	
		4 cylinders and more	less than 4 cylinders
impact-free	1,0	1,5	2,0
low impact	1,5	2,0	2,5
high impact	2,0	2,5	3,0

Coupling		Torque	Flywheel effect	$\frac{P}{n}$	n max.	Pilot hole d min.	D	l	B	Required space		Weight
No..	Ind.	Md Nm	mD ² kgm ²							G	L	q max. kg/piece
450 18	^{29,30}	38	0,000 405	0,0039	8 000	10	38	20	8,2	53,5	43,0	0,41
455 14	^{29,30}	60	0,000 410	0,0062	6 000	12	33	22	15,2	51,8	49,0	0,41
455 18	^{29,30}	95	0,001 170	0,0097	6 000	12	45	25	15,2	63,9	55,0	0,78
462 14	^{29,30}	150	0,001 650	0,0154	5 500	15	44	28	20,7	70,0	63,0	0,93
462 18	^{29,30}	240	0,004 740	0,0246	5 500	15	60	32	20,7	86,0	71,0	1,83
501 18	^{29,30}	380	0,013	0,0390	4 500	15	75	35	25,0	107,0	78,0	3,21
513 18	^{29,30}	600	0,030 100	0,0616	3 000	25	90	40	29,5	126,5	89,5	4,97
513 24	^{29,30}	940	0,107	0,0965	2 500	25	125	50	29,5	162,5	109,5	10,90
548 18	^{29,30}	1 480	0,158	0,1519	2 500	30	120	60	46,7	170,0	137,0	12,30
548 24	^{29,30}	2 350	0,517	0,2413	2 000	30	165	70	46,7	219,0	157,0	27,65
563 22	^{29,30}	3 700	0,882	0,3798	1 800	40	180	75	53,5	250,0	169,5	37,50
596 18	^{29,30}	5 800	1,160	0,5954	1 200	50	180	80	70,4	256,0	186,5	43,50
596 24	^{29,30}	9 200	3,250	0,9445	1 200	50	220	100	70,4	328,0	226,5	78,50
652 22		14 500	7,940	1,4887	1 000	60	260	120	85,6	401,0	272,0	138,00
671 20		23 000	18,710	2,3613	800	75	300	150	105,3	466,0	340,0	231,00

* can also be supplied in maintenance-free MARATHON design. In this case please put MA after the number for the coupling, e.g. 462 14 MA

³⁰ with tooth flank hardening

Couplings are supplied unassembled and the loose chain is enclosed.
Other sprockets, number of teeth, chain types and dimensions on request.

For enquiries and orders please supply the following details:

1. Number of couplings
2. Chain pitch
3. Number of teeth
4. Coupling No. or alternatively torque to be transmitted
5. Bores of coupling halves
6. Groove sizes (for keyways also tightening direction); without additional specifications we will supply sprockets on the basis of DIN 6885 sheet 1



Standard sprockets

Standard sprockets can be supplied ex stock with custom bore or bored and grooved "ready-to-install" at extra cost.

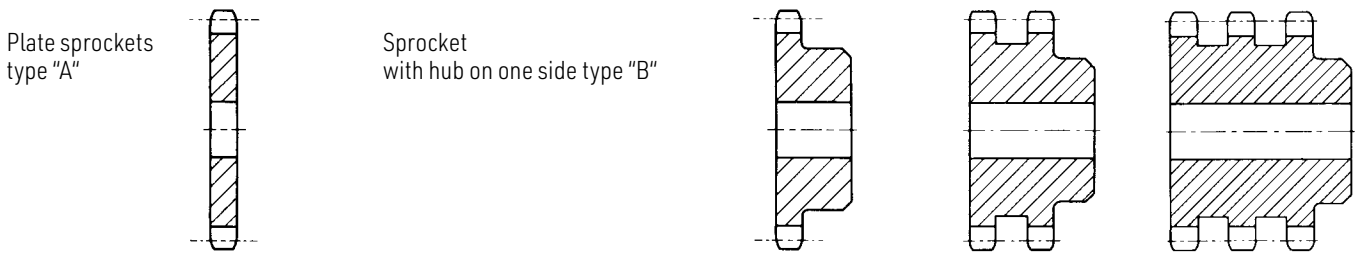

Sprockets made to specifications

Sprockets can be manufactured to your specifications and drawings.

Sprockets with hub on both sides (type "C") can be symmetrical or asymmetrical. For asymmetrical hub lengths the two hub sections l_1 and l_2 up to the centre of the sprocket must be stated in your order.

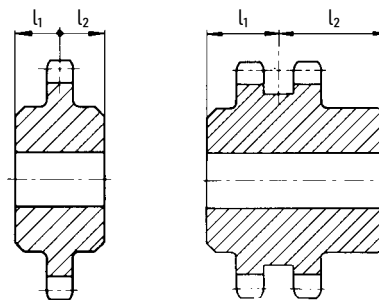

Material grades

For sprockets with a diameter of up to approx. 300 mm unalloyed steel with a steel strength of 500 - 600 N/mm² (S355J0C, C45 and the like) are usually sufficient. For larger sprockets cast iron suffices in case of normal loads. For drive pinions subjected to high

loads with speeds of more than 500 rpm or with chain speeds of more than 1m/s it is recommended to harden or to harden and temper the teeth to 50 ± 2 HRC.

Groove sizes

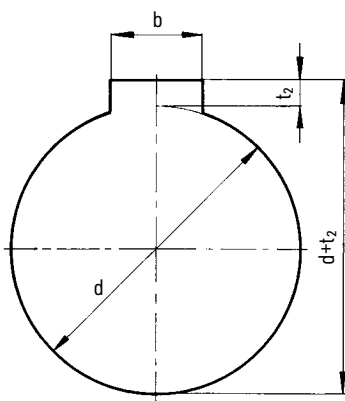

Groove sizes for woodruff keys DIN 6888 are in accordance with: DIN 6885 sheet 1 (with clearance) design A, DIN 6885 sheet 2 design B

We manufacture hub grooves only when specifically ordered by our customers. If no further specifications are given, we will work according to DIN 6885 sheet 1.

DIN	for shaft diameter	Groove width	Feather keys				Keyways		Hollow keys	Flat keys	
			6885		6885		6886	6887	6881/6889	6883/6884	
			Sheet 1	Sheet 2	Sheet 3						
	d	b	Nuttiefe t_2								
			with clearance	with over-size		with clearance	with over-size				
more than	6 to 8	2,0	1,0	0,5	-	-	-	0,5	-	-	-
"	8 " 10	3,0	1,4	0,9	-	-	-	0,9	-	-	-
"	10 " 12	4,0	1,8	1,2	1,1	-	-	1,2	1,2	-	-
"	12 " 17	5,0	2,3	1,7	1,3	1,2	0,8	1,7	1,7	-	-
"	17 " 22	6,0	2,8	2,2	1,7	1,6	1,1	2,2	2,2	-	-
"	22 " 30	8,0	3,3	2,4	1,7	2,0	1,4	2,4	2,4	3,2	3,2
"	30 " 38	10,0	3,3	2,4	2,1	2,4	1,8	2,4	2,4	3,7	3,7
"	38 " 44	12,0	3,3	2,4	2,1	2,2	1,6	2,4	2,4	3,7	3,7
"	44 " 50	14,0	3,8	2,9	2,6	2,1	1,4	2,9	2,9	4,0	4,0
"	50 " 58	16,0	4,3	3,4	2,6	2,4	1,7	3,4	3,4	4,5	4,5
"	58 " 65	18,0	4,4	3,4	3,1	2,3	1,6	3,4	3,4	4,5	4,5
"	65 " 75	20,0	4,9	3,9	4,1	2,7	2,0	3,9	3,9	5,5	5,5
"	75 " 85	22,0	5,4	4,4	4,1	3,1	2,4	4,4	4,4	6,5	6,5
"	85 " 95	25,0	5,4	4,4	4,1	2,9	2,2	4,4	4,4	6,4	6,4
"	95 " 110	28,0	6,4	5,4	5,1	3,2	2,4	5,4	5,4	6,9	6,9
"	110 " 130	32,0	7,4	6,4	5,2	3,5	2,7	6,4	6,4	7,9	7,9
"	130 " 150	36,0	8,4	7,1	6,5	3,8	3,0	7,1	7,1	8,4	8,4
"	150 " 170	40,0	9,4	8,1	8,2	-	-	8,1	8,1	-	9,1
"	170 " 200	45,0	10,4	9,1	-	-	-	9,1	9,1	-	10,4
"	200 " 230	50,0	11,4	10,1	-	-	-	10,1	10,1	-	11,7
"	230 " 260	56,0	12,4	11,1	-	-	-	11,1	11,1	-	-

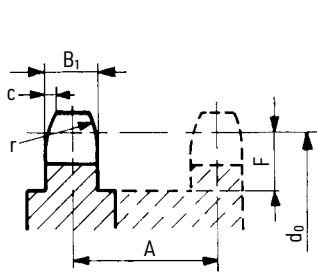

Simplex or 2 x simplex

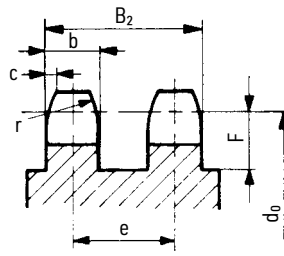

Duplex

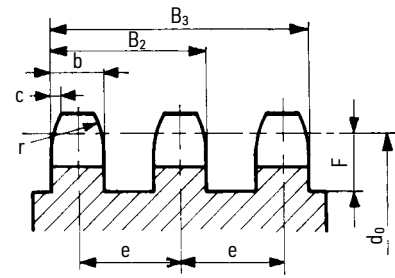

Triplex

 B_1 : Tooth width for simplex sprocket

 b : Tooth width for multiplex sprocket

 B_2 : Tooth width over duplex sprocket

 B_3 : Tooth width over triplex sprocket

 c : Chamfer of tooth width 0,1 to 0,15 p

 r : Tooth chamfer radius $\geq p$
 e : Transverse pitch

 F : Undercut

 A : Centre to centre distance for separated chain strands

(only for 2 x simplex roller chain, each with outer connecting side)

Roller chains according to ISO 606 (European type)

Chain ⚙️ No.	Chain dimensions				Profile dimensions						
	Pitch		Inner width	Roller Ø	e	B_1 h14	b h14	B_2^*	B_3^*	F min.	A min.
	p		b_1 min.	d_1 h9							
440	5,000	-	2,50	3,20	-	2,3	-	-	-	3,0	9
445, D 445	6,000	-	2,80	4,00	5,50	2,6	2,5	8,0	-	3,5	9
450, D 450, T 450	8,000	-	3,00	5,00	5,64	2,8	2,7	8,3	14,0	5,0	10
453	9,525	$\frac{3}{8}$	3,30	6,00	-	3,0	-	-	-	6,0	11
454	9,525	$\frac{3}{8}$	3,94	6,35	-	3,6	-	-	-	6,0	13
455, D 455, T 455	9,525	$\frac{3}{8}$	5,72	6,35	10,24	5,3	5,2	15,4	25,7	6,0	15
331	12,700	$\frac{1}{2}$	3,30	7,75	-	3,0	-	-	-	7,0	12
332, 17	12,700	$\frac{1}{2}$	4,88	7,75	-	4,5	-	-	-	7,0	15
110	12,700	$\frac{1}{2}$	2,38	7,75	-	2,2	-	-	-	7,0	9
41	12,700	$\frac{1}{2}$	6,38	7,75	-	5,9	-	-	-	7,0	16
385	12,700	$\frac{1}{2}$	6,40	7,75	-	5,9	-	-	-	8,0	18
461	12,700	$\frac{1}{2}$	6,40	8,51	-	5,9	-	-	-	8,0	18
462, D 462, T 462	12,700	$\frac{1}{2}$	7,75	8,51	13,92	7,2	7,0	21,0	34,8	8,0	20
500	15,875	$\frac{5}{8}$	6,48	10,16	-	6,1	-	-	-	10,0	19
501, D 501, T 501	15,875	$\frac{5}{8}$	9,65	10,16	16,59	9,1	9,0	25,6	42,2	10,0	23
513, D 513, T 513	19,050	$\frac{3}{4}$	11,68	12,07	19,46	11,1	10,8	30,3	49,7	11,0	27
548, D 548, T 548	25,400	1	17,02	15,88	31,88	16,2	15,8	47,7	79,6	15,0	42
552	30,000	-	17,02	15,88	-	16,2	-	-	-	15,0	42
563, D 563, T 563	31,750	1 $\frac{1}{4}$	19,56	19,05	36,45	18,5	18,2	54,6	91,1	18,0	50
596, D 596, T 596	38,100	1 $\frac{1}{2}$	25,40	25,40	48,36	24,1	23,6	72,0	120,3	23,0	63
613, D 613, T 613	44,450	1 $\frac{3}{4}$	30,99	27,94	59,56	29,4	28,8	88,4	147,9	25,0	76
652, D 652, T 652	50,800	2	30,99	29,21	58,55	29,4	28,8	87,4	145,9	29,0	79
671, D 671, T 671	63,500	2 $\frac{1}{2}$	38,10	39,37	72,29	36,2	35,4	107,7	180,0	36,0	97
679, D 679, T 679	76,200	3	45,72	48,26	91,21	43,4	42,5	133,7	224,9	43,0	116

Roller chains according to ISO 606 (American type)

35, 35-2, 35-3	9,525	$\frac{3}{8}$	4,77	5,08	10,13	4,4	4,3	14,4	24,5	6,0	15
40, 40-2, 40-3	12,700	$\frac{1}{2}$	7,85	7,95	14,38	7,4	7,2	21,6	36,0	8,0	20
50, 50-2, 50-3	15,875	$\frac{5}{8}$	9,40	10,16	18,11	9,0	8,8	26,9	45,0	10,0	25
60, 60 H, 60-2, 60-3	19,050	$\frac{3}{4}$	12,57	11,91	22,78	12,0	11,8	34,6	57,3	12,0	31/33**
80, 80 H, 80-2, 80-3	25,400	1	15,75	15,88	29,29	15,1	14,8	44,1	73,4	16,0	39/42**
100, 100 H, 100-2, 100-3	31,750	1 $\frac{1}{4}$	18,90	19,05	35,76	18,1	17,7	53,4	89,2	20,0	48/51**
120, 120-2, 120-3	38,100	1 $\frac{1}{2}$	25,22	22,23	45,44	24,1	23,6	69,0	114,5	24,0	60
140, 140-2, 140-3	44,450	1 $\frac{3}{4}$	25,22	25,40	48,87	24,1	23,6	72,5	121,3	28,0	64
160, 160-2, 160-3	50,800	2	31,55	28,58	58,55	30,1	29,5	88,0	146,6	32,0	77
200, 200-2, 200-3	63,500	2 $\frac{1}{2}$	37,85	39,68	71,55	36,2	35,4	106,9	178,5	40,0	94

* rounded off values ** the second value only applies to chains of type series "H"

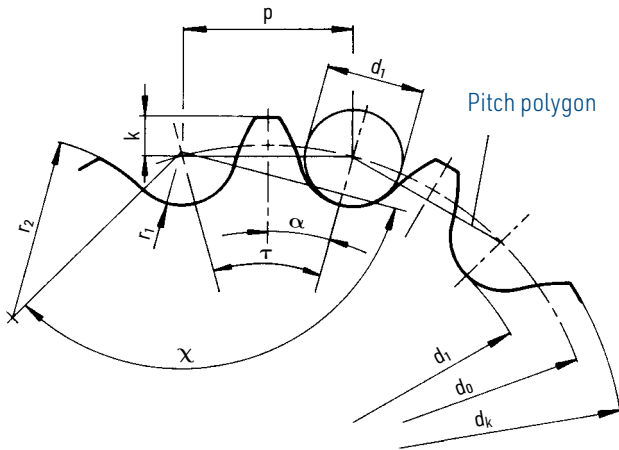

- p : Pitch
- z : Number of teeth
- d₁ : Roller diameter, bushing diameter or pin diameter
- d₀ : PCD
- d_k : Tip circle diameter
- d_f : Root circle diameter
- t : Pitch angel = $\frac{360^\circ}{z}$ $\alpha = \frac{180^\circ}{z}$
- x : Roller contact angle
- k : Tooth height above pitch polygon
(Diameter of pitch polygon = p cot α)
- r₁ : Tooth root radius
- r₂ : Tooth profile radius
- n : Factor for the number of teeth = $\frac{1}{\sin \alpha} = \frac{1}{\sin(180^\circ/Z)}$

PCD

$$d_0 = \frac{p}{\sin \alpha} = \frac{p}{\sin(180^\circ/Z)} = pn$$

Tip circle diameter d_k

a) Roller chain sprockets

$$d_k = p \cot \alpha + 0,8 d_1 = d_0 \cos \alpha + 0,8 d_1$$

the following applies with sufficient accuracy:

d _k = d ₀ + 0,5 ... 0,6 d ₁	z = 6 ... 12 teeth
d _k = d ₀ + 0,6 ... 0,7 d ₁	z = 13 ... 25 teeth
d _k = d ₀ + 0,7 ... 0,8 d ₁	z = more than 25 teeth

b) Bush chain sprockets

$$d_k = d_0 + 0,8 \dots 1,0 d_1$$

c) Galle chain sprockets

$$d_k = d_0 + d_1$$

Root circle diameter

$$d_f = d_0 - d_1$$

Toothing check

a) by measuring

In order to check the sprocket toothing the root circle diameter must be determined by means of measuring pins with the same diameters as the chain rollers,

but with the tolerance $\begin{matrix} +0,01 \\ 0,00 \end{matrix}$

For an even number of teeth the measure M is:

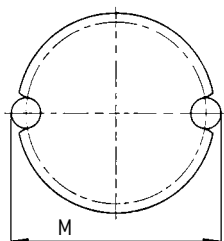

$$M = d_0 + d_1$$

$$M = pn + d_1$$

For an uneven number of teeth the measure M is:
over 2 measuring pins over 3 measuring pins

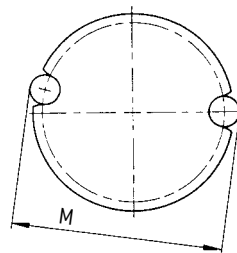

$$M = d_0 \cos \frac{\alpha}{2} + d_1$$

$$M = pn \cos \frac{\alpha}{2} + d_1$$

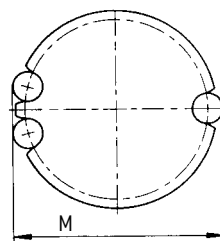

$$M = \frac{p}{2} \left(\frac{1}{\sin \alpha} + \cot \alpha \right) + d_1$$

$$M = \frac{p}{2} (n + \cot \alpha) + d_1$$

b) by means of a chain looped around the sprocket

It must be possible to fully loop the chain around the sprocket quite easily. If the toothing was milled too deeply, the sprocket is defective and must be scrapped! In case of the root circle diameter being too long (i.e. the chain cannot be looped around the sprocket and moves upwards on the tooth flanks after a few links), the sprocket can be milled again.

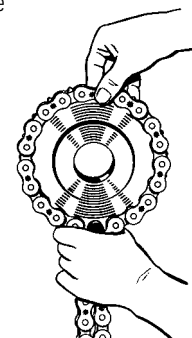

Tooting check by means of a chain looped around the sprocket

For permissible deviations of the measure M the tolerances of the root circle diameter (h₁₁) apply.

In order to avoid errors or misunderstandings please supply the following details:

Plate sprocket Type "A"

(for simplex roller chains according to DIN 8187)

1. Number of plate sprockets
2. ☉ -plate sprocket No. (e.g. plate sprocket with 20 teeth for simplex roller chain No. 462 - 1/2" x 5/16" = A 20 462)
3. Custom bore size (fit normal H7)

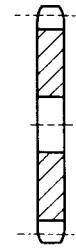

Type A

Sprocket Type "B"

(for simplex, duplex and triplex roller chains according to DIN 8187)

1. Number of sprockets
2. ☉ -sprocket No. (e.g. sprocket with 23 teeth for duplex roller chain No. D 501 - 5/8" x 3/8" = B 23 D 501)
3. Custom bore size (fit normal H7)
4. Groove sizes (for keyways also tightening direction); without additional specifications (e.g. if you merely state groove according to DIN) we will supply sprockets on the basis of DIN 6885 sheet 1
5. Inside threads or pin holes

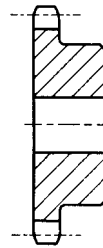

Type B

Sprockets in special designs

(for all chains in our manufacturing line)

1. Number of sprockets
2. Appropriate ☉ -chain No. or ISO No.; alternatively pitch p, inner width b1 (between inner plates) and roller-Ø, pin-Ø or bushing-Ø
3. Number of teeth z
4. Bore size and fit
5. Hub diameter and hub length
6. Hub seat (one-sided or symmetrical); in case of asymmetrical hubs please state the two hub sections up to the sprocket centre
7. Groove sizes (for keyways also tightening direction)
8. Inside threads or pin holes

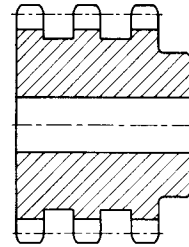
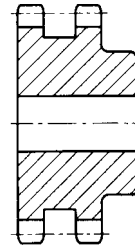

It is advisable to include a precise drawing when ordering sprockets in special designs.

Toothing

(for all chains in our manufacturing line including inverted tooth chains up to p = 25,4 mm)

1. Number of wheel bodies to be toothed
2. ☉ -chain No. or ISO No.; alternatively pitch p, inner width b1 (between inner plates) and roller-Ø, pin-Ø or bushing-Ø
3. Number of teeth

Grooves

1. Number of parts to be grooved
2. Groove sizes (normal DIN 6885 sheet 1)

Lantern gear toothing

1. Number of lantern gears

Chain tensioner SPANN-BOX®

1. Number of chain tensioners SPANN-BOX®
2. ☉ -chain No. or ISO No.
3. SPANN-BOX® size
4. Sliding profile (arch, semicircle or deflecting profile)
5. Spring tension (high or low) and design (ordinary steel or grade 1.4301 [V2 A])

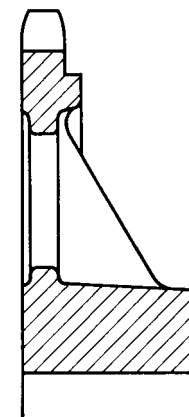

Type B (Cast iron)

ETP Bushings

1. Number of bushings
2. Order number

Alignment of the sprockets

The wear life of a chain largely depends on the proper alignment of the sprockets. Sprockets must always align exactly. Alignment can be checked by means of a long ruler applied across the sprockets. This check must be repeated several times with the sprockets turned a little further each time. Subsequently, they have to be secured in axial direction.

The shafts must be aligned exactly horizontally. They must be axially parallel and free from runout. In order to avoid vibrations they should be dimensioned according to the weight of the sprockets, the design layout and the loads.

Chain tensioning

Unlike belt drives, chains do not require pre-tensioning, and they should have a slight slack span (see page 142). Chains must not be overtightened, since this would load the drive unnecessarily and lead to premature wear of the chain. However, if chains are fitted too loosely, they tend to "jump off" the sprockets. The chain slack span should be checked after a few weeks. Initial elongation is higher than during the subsequent operation period due to running-in wear.

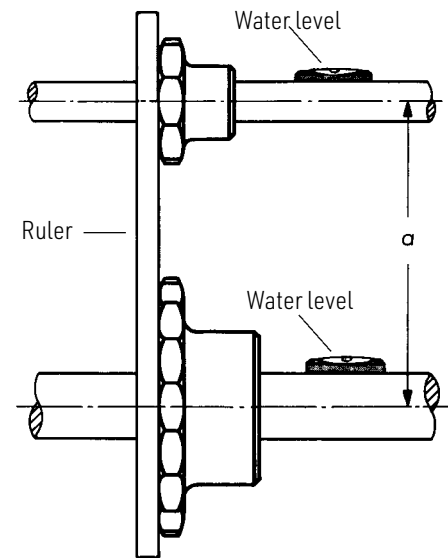

Faulty mounting

Chain runs on laterally offset sprockets

In this case the sprockets are not lopsided, but they are laterally offset. Therefore the chain runs laterally skewed. As a result, the chain plates heavily grind on the teeth of the sprocket and wear quickly. The lateral pressure also loosens the riveting. The chain cannot run smoothly and there is a relatively strong elongation due to the strong wear between pins and bushings.



Tilted position of sprockets

Originally the sprockets were aligned. During tensioning the gear mechanism shifted and is now in an angle to the line of the sprocket on the machine shaft. The consequences are the same as before. Apart from that, axial forces put pressure on the machine and gearing shafts.

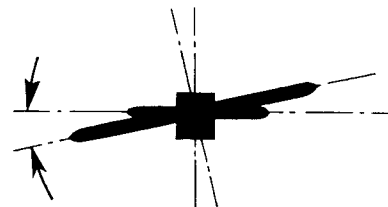

Skewed position of sprockets

The drawing shows that the sprockets are aligned, but that they are skewed, so that the driven sprocket, for example, has now a tilted position against the angle. In this case, the chain is also subject to extreme load and will wear prematurely.





Chain No. 	440		445 D 450		450 D 450 T 450		35 35-2 35-3		453, 454 455 D 455 T 455		17, 18, 41 110, 331 40 40-2 40-3	
	Pitch p	5,0	6,0		8,0		9,525		9,525		12,7	
Roller-Ø d_1	3,2	4,0		5,0		5,08		6,0 - 6,35		7,75 - 7,95		
Number of teeth z	PCD	Tip circle Ø	PCD	Tip circle Ø	PCD	Tip circle Ø	PCD	Tip circle Ø	PCD	Tip circle Ø	PCD	Tip circle Ø
	d_0	d_k	d_0	d_k	d_0	d_k	d_0	d_k	d_0	d_k	d_0	d_k
11	17,75	19,6	21,30	23,6	28,40	31,2	33,81	36,5	33,81	37,5	45,08	49,6
12	19,32	21,2	23,18	25,6	30,91	33,8	36,80	39,6	36,80	40,6	49,07	53,8
13	20,89	22,8	25,07	27,5	33,43	36,4	39,80	42,7	39,80	43,7	53,07	57,9
14	22,47	24,5	26,96	29,5	35,95	39,0	42,81	45,8	42,81	46,8	57,07	62,0
15	24,05	26,1	28,86	31,4	38,48	41,6	45,81	48,9	45,81	49,9	61,08	66,1
16	25,63	27,7	30,75	33,3	41,01	44,2	48,82	52,0	48,82	53,0	65,10	70,2
17	27,21	29,3	32,65	35,2	43,54	46,8	51,84	55,0	51,84	56,0	69,12	74,3
18	28,79	30,9	34,55	37,2	46,07	49,5	54,85	58,1	54,85	59,1	73,14	78,4
19	30,38	32,5	36,45	39,1	48,60	51,9	57,87	61,2	57,87	62,2	77,16	82,5
20	31,96	34,2	38,36	41,1	51,14	54,5	60,89	64,2	60,89	65,2	81,18	86,6
21	33,55	35,7	40,26	43,0	53,68	57,1	63,91	67,3	63,91	68,3	85,21	90,6
22	35,13	37,3	42,16	44,9	56,21	59,6	66,93	70,3	66,93	71,3	89,24	94,7
23	36,72	38,9	44,06	46,8	58,75	62,2	69,95	73,4	69,95	74,4	93,27	98,8
24	38,31	40,5	45,97	48,8	61,29	64,8	72,97	76,4	72,97	77,4	97,30	102,9
25	39,89	42,2	47,87	50,7	63,83	67,3	76,00	79,5	76,00	80,5	101,33	106,9
26	41,48	43,7	49,78	52,6	66,37	69,9	79,02	82,5	79,02	83,5	105,36	111,0
27	43,07	45,3	51,68	54,5	68,91	72,4	82,05	85,6	82,05	86,6	109,40	115,0
28	44,66	46,9	53,59	56,4	71,45	75,0	85,07	88,6	85,07	89,6	113,43	119,1
29	46,25	48,5	55,49	58,4	73,99	77,5	88,10	91,7	88,10	92,7	117,46	123,2
30	47,83	50,1	57,40	60,3	76,53	80,1	91,12	94,7	91,12	95,7	121,50	127,2
31	49,42	51,7	59,31	62,2	79,08	82,7	94,15	97,8	94,15	98,8	125,53	131,3
32	51,01	53,3	61,21	64,1	81,62	85,7	97,18	100,8	97,18	101,8	129,57	135,3
33	52,60	54,9	63,12	66,0	84,16	87,8	100,20	103,8	100,20	104,8	133,61	139,4
34	54,19	56,5	65,03	67,9	86,70	90,3	103,23	106,9	103,23	107,9	137,64	143,4
35	55,78	58,2	66,93	69,8	89,25	92,9	106,26	109,9	106,26	110,9	141,68	147,5
36	57,37	59,7	68,84	71,8	91,79	95,4	109,29	113,0	109,29	114,0	145,72	151,5
37	58,96	61,3	70,75	73,7	94,33	98,0	112,31	116,0	112,31	117,0	149,75	155,6
38	60,55	62,9	72,66	75,6	96,88	100,5	115,34	119,0	115,34	120,0	153,79	159,6
39	62,14	64,5	74,57	77,5	99,42	103,1	118,37	122,1	118,37	123,1	157,83	163,7
40	63,73	66,1	76,47	79,4	101,96	105,6	121,40	125,1	121,40	126,1	161,87	167,7
41	65,32	67,7	78,38	81,3	104,51	108,2	124,43	128,1	124,43	129,1	165,91	171,8
42	66,91	69,3	80,29	83,2	107,05	110,7	127,46	131,2	127,46	132,2	169,95	175,9
43	68,50	70,9	82,20	85,2	109,60	113,3	130,49	134,2	130,49	135,2	173,98	179,9
44	70,09	72,5	84,11	87,1	112,14	115,8	133,52	137,2	133,52	138,2	178,02	184,0
45	71,68	74,1	86,01	89,0	114,68	118,4	136,55	140,3	136,55	141,3	182,06	188,0
46	73,27	75,7	87,92	90,9	117,23	120,9	139,58	143,3	139,58	144,3	186,10	192,0
47	74,86	77,3	89,83	92,8	119,77	123,5	142,61	146,4	142,61	147,4	190,14	196,1
48	76,45	78,8	91,74	94,7	122,32	126,0	145,64	149,4	145,64	150,4	194,18	200,1
49	78,04	80,4	93,65	96,6	124,86	128,6	148,67	152,4	148,67	153,4	198,22	204,2
50	79,63	82,0	95,56	98,5	127,41	131,1	151,70	155,5	151,70	156,5	202,26	208,2
51	81,22	83,6	97,46	100,5	129,95	133,7	154,73	158,5	154,73	159,5	206,30	212,3
52	82,81	85,2	99,37	102,4	132,50	136,2	157,75	161,5	157,75	162,5	210,34	216,3
53	84,40	86,8	101,28	104,3	135,04	138,8	160,78	164,5	160,78	165,6	214,38	220,4
54	85,99	88,4	103,19	106,2	137,59	141,3	163,81	167,6	163,81	168,6	218,42	224,4
55	87,58	90,0	105,10	108,1	140,13	143,9	166,85	170,6	166,85	171,6	222,46	228,5
56	89,17	91,6	107,01	110,0	142,68	146,4	169,88	173,7	169,88	174,7	226,50	232,5
57	90,76	93,2	108,92	111,9	145,22	149,0	172,91	176,7	172,91	177,7	230,54	236,6
58	92,36	94,8	110,83	113,8	147,77	151,5	175,94	179,8	175,94	180,8	234,58	240,6
59	93,95	96,4	112,74	115,8	150,31	154,1	178,97	182,8	178,97	183,8	238,62	244,7
60	95,54	98,0	114,64	117,7	152,86	156,7	182,00	185,8	182,00	186,8	242,66	248,7
61	97,13	99,6	116,55	119,6	155,40	159,2	185,03	188,9	185,03	189,9	246,70	252,8
62	98,72	101,2	118,46	121,5	157,95	161,7	188,06	191,9	188,06	192,9	250,74	256,8
63	100,31	102,7	120,37	123,4	160,50	164,3	191,09	194,9	191,09	195,9	254,79	260,9
64	101,90	104,3	122,28	125,3	163,04	166,8	194,12	198,0	194,12	199,0	258,83	264,9
65	103,49	105,9	124,19	127,2	165,59	169,4	197,15	201,0	197,15	202,0	262,87	268,9
66	105,08	107,5	126,10	129,1	168,13	171,9	200,18	204,0	200,18	205,0	266,91	273,0
67	106,67	109,1	128,01	131,0	170,68	174,5	203,21	207,1	203,21	208,1	270,95	277,0
68	108,26	110,7	129,92	132,9	173,22	177,0	206,24	210,1	206,24	211,1	274,99	281,1
69	109,86	112,3	131,83	134,9	175,77	179,6	209,27	213,1	209,27	214,1	279,03	285,1
70	111,45	113,9	133,74	136,8	178,31	182,1	212,30	216,2	212,30	217,2	283,07	289,2

All dimensions in mm



Chain No. 	460 461 462 D 462 T 462		50 H 50 HX 50 50-2 50-3		500 501 D 501 F 501		60 60-2 60-3 60 H 60 HX		513 D 513 T 513 515 517		80 H 80 HX 80 80-2 80-3		548 D 548 T 548		100 HX 100 100-2 100-3		563 D 563 T 563		120 HX 120 120-2 120-3	
	Pitch p	12,7		15,875		19,05		25,4		31,75		38,1								
Roller-Ø d_1	8,51		10,16		11,91 - 12,07		15,88		19,05		22,23									
Number of teeth z	PCD d_0		Tip circle Ø d_k		PCD d_0		Tip circle Ø d_k		PCD d_0		Tip circle Ø d_k		PCD d_0		Tip circle Ø d_k		PCD d_0		Tip circle Ø d_k	
	11	45,08	50,0	56,35	62,2	67,62	74,5	90,16	99,2	112,69	123,4	135,23	147,6							
12	49,07	54,2	61,34	67,4	73,60	80,7	98,14	107,5	122,67	133,7	147,21	160,0								
13	53,07	58,3	66,34	72,5	79,60	86,9	106,14	115,7	132,67	144,0	159,21	172,4								
14	57,07	62,4	71,34	77,7	85,61	93,1	114,15	124,0	142,68	154,3	171,22	184,7								
15	61,08	66,5	76,35	82,8	91,62	99,2	122,17	132,2	152,71	164,6	183,25	197,0								
16	65,10	70,6	81,37	87,9	97,65	105,4	130,20	140,4	162,74	174,9	195,29	209,3								
17	69,12	74,7	86,39	93,0	103,67	111,5	138,23	148,5	172,79	185,1	207,35	221,6								
18	73,14	78,8	91,42	98,1	109,71	117,7	146,27	156,7	182,84	195,3	219,41	233,9								
19	77,16	82,9	96,45	103,2	115,74	123,8	154,32	164,9	192,90	205,5	231,48	246,1								
20	81,18	87,0	101,48	108,3	121,78	129,9	162,37	173,0	202,96	215,7	243,55	258,4								
21	85,21	91,0	106,51	113,4	127,82	136,0	170,42	181,2	213,03	225,9	255,63	270,6								
22	89,24	95,1	111,55	118,5	133,86	142,1	178,48	189,3	223,10	236,1	267,72	282,8								
23	93,27	99,2	116,59	123,6	139,90	148,2	186,54	197,5	233,17	246,2	279,81	295,0								
24	97,30	103,3	121,62	128,7	145,95	154,3	194,60	205,6	243,25	256,4	291,90	307,2								
25	101,33	107,3	126,66	133,8	151,99	160,4	202,66	213,7	253,32	266,6	303,99	319,4								
26	105,36	111,4	131,70	138,8	158,04	166,5	210,72	221,9	263,40	276,7	316,09	331,6								
27	109,40	115,4	136,74	143,9	164,09	172,6	218,79	230,0	273,49	286,9	328,19	343,8								
28	113,43	119,5	141,79	149,0	170,14	178,7	226,86	238,1	283,57	297,0	340,29	355,9								
29	117,46	123,6	146,83	154,1	176,20	184,8	234,93	246,2	293,66	307,2	352,39	368,1								
30	121,50	127,6	151,87	159,1	182,25	190,9	243,00	254,3	303,75	317,3	364,50	380,3								
31	125,53	131,7	156,92	164,2	188,30	197,0	251,07	262,5	313,83	327,5	376,60	392,5								
32	129,57	135,7	161,96	169,3	194,35	203,0	259,14	270,6	323,92	337,6	388,71	404,6								
33	133,61	139,8	167,01	174,4	200,41	209,1	267,21	278,7	334,01	347,7	400,82	416,8								
34	137,64	143,8	172,05	179,4	206,46	215,2	275,29	286,8	344,11	357,9	412,93	428,9								
35	141,68	147,9	177,10	184,5	212,52	221,3	283,36	294,9	354,20	368,0	425,04	441,1								
36	145,72	152,0	182,14	189,6	218,57	227,4	291,43	303,0	364,29	378,1	437,15	453,3								
37	149,75	156,0	187,19	194,6	224,63	233,5	299,51	311,1	374,38	388,3	449,26	465,4								
38	153,79	160,1	192,24	199,7	230,69	239,5	307,58	319,2	384,48	398,4	461,38	477,6								
39	157,83	164,1	197,29	204,8	236,74	245,6	315,66	327,3	394,57	408,5	473,49	489,8								
40	161,87	168,2	202,35	209,8	242,80	251,7	323,74	335,4	404,67	418,7	485,60	501,9								
41	165,91	172,2	207,38	214,9	248,86	257,8	331,81	343,5	414,77	428,8	497,72	514,1								
42	169,95	176,3	212,43	219,9	254,92	263,8	339,89	351,6	424,86	438,9	509,84	526,2								
43	173,98	180,3	217,48	225,0	260,98	269,9	347,97	359,7	434,96	449,0	521,95	538,4								
44	178,02	184,4	222,53	230,1	267,04	276,0	356,05	367,8	445,06	459,2	534,07	551,5								
45	182,06	188,4	227,58	235,1	273,09	282,0	364,12	375,9	455,16	469,3	546,19	562,6								
46	186,10	192,5	232,63	240,2	279,15	288,1	372,20	384,0	465,25	479,4	558,31	574,8								
47	190,14	196,5	237,68	245,3	285,21	294,2	380,28	392,1	475,35	489,5	570,42	586,9								
48	194,18	200,6	242,73	250,3	291,27	300,3	388,36	400,2	485,45	499,6	582,54	599,1								
49	198,22	204,6	247,78	255,4	297,33	306,4	396,44	408,3	495,55	509,8	594,66	611,2								
50	202,26	208,6	252,83	260,4	303,39	312,4	404,52	416,4	505,65	519,9	606,78	623,4								
51	206,30	212,7	257,88	265,5	309,45	318,5	412,60	424,5	515,75	530,0	618,90	635,5								
52	210,34	216,7	262,93	270,6	315,51	324,6	420,68	432,6	525,85	540,1	631,02	647,8								
53	214,38	220,8	267,97	275,6	321,57	330,6	428,76	440,7	535,95	550,2	643,14	659,8								
54	218,42	224,8	273,02	280,7	327,63	336,7	436,84	448,8	546,05	560,4	655,26	671,9								
55	222,46	228,9	278,08	285,7	333,69	342,8	444,92	456,9	556,15	570,5	667,38	684,1								
56	226,50	232,9	283,13	290,8	339,75	348,8	453,00	465,0	566,25	580,6	679,50	696,2								
57	230,54	237,0	288,18	295,8	345,81	354,9	461,08	473,1	576,35	590,7	691,63	708,4								
58	234,58	241,0	293,23	300,9	351,87	361,0	469,16	481,2	586,45	600,8	703,75	720,5								
59	238,62	245,1	298,28	306,0	357,93	367,0	477,24	489,2	596,56	610,9	715,87	732,6								
60	242,66	249,1	303,33	311,0	363,99	373,1	485,33	497,3	606,66	621,0	727,99	744,8								
61	246,70	253,2	308,38	316,1	370,06	379,2	493,41	505,4	616,76	631,1	740,11	756,9								
62	250,74	257,2	313,43	321,1	376,12	385,3	501,49	513,5	626,86	641,3	752,23	769,1								
63	254,79	261,3	318,48	326,2	382,18	391,3	509,57	521,6	636,97	651,4	764,36	781,2								
64	258,83	265,3	323,53	331,2	388,24	397,4	517,65	529,7	647,07	661,5	776,48	793,3								
65	262,87	269,4	328,58	336,3	394,30	403,5	525,73	537,8	657,17	671,6	788,60	805,5								
66	266,91	273,4	333,64	341,4	400,36	409,5	533,82	545,9	667,27	681,7	800,72	817,6								
67	270,95	277,4	338,69	346,4	406,42	415,6	541,90	554,0	677,37	691,9	812,85	829,8								
68	274,99	281,5	343,74	351,5	412,49	421,7	549,98	562,1	687,48	701,9	824,97	841,9								
69	279,03	285,5	348,79	356,5	418,55	427,7	558,06	570,2	697,58	712,0	837,10	854,0								
70	283,07	289,6	353,84	361,6	424,61	433,8	566,15	578,2	707,68	722,2	849,22	866,1								

All dimensions in mm



Chain No. 	596 R 596 SX 596 D 596 T 596		140 HX 140 140-2 140-3		613 D 613 T 613		160 HX 160 160-2 160-3		652 D 652 T 652		200 HX 200 200-2 200-3		671 SX D 671 T 671		679 D 679 T 679	
	Pitch p	38,1		44,45		44,45		50,8		63,5		76,2				
Roller-Ø d_1	25,4		25,4		27,94		28,58 - 29,21		39,37 - 39,68		48,26					
Number of teeth z	PCD		Tip circle Ø		PCD		Tip circle Ø		PCD		Tip circle Ø		PCD		Tip circle Ø	
	d_0	d_k	d_0	d_k	d_0	d_k	d_0	d_k	d_0	d_k	d_0	d_k	d_0	d_k	d_0	d_k
11	135,23	150,0	157,77	171,8	157,77	173,8	180,31	196,4	225,39	248,1	270,47	298,1				
12	147,21	162,5	171,74	186,3	171,74	188,3	196,28	213,0	245,35	268,8	294,41	323,0				
13	159,21	174,9	185,74	200,7	185,74	202,7	212,27	229,5	265,34	289,4	318,41	347,7				
14	171,22	187,2	199,76	215,1	199,76	217,1	228,30	246,0	285,37	310,0	342,44	372,5				
15	183,25	199,5	213,79	229,5	213,79	231,5	244,33	262,4	305,42	330,5	366,50	397,1				
16	195,29	211,8	227,84	243,9	227,84	245,9	260,39	278,8	325,49	351,0	390,59	421,7				
17	207,35	224,1	241,91	258,2	241,91	260,2	276,46	295,2	345,58	371,5	414,70	446,2				
18	219,41	236,3	255,98	272,5	255,98	274,5	292,55	311,5	365,68	391,9	438,82	470,7				
19	231,48	248,6	270,06	286,8	270,06	288,8	308,64	327,8	385,79	412,3	462,95	495,2				
20	243,55	260,9	284,15	301,0	284,15	303,0	324,74	344,1	405,92	432,7	487,11	519,7				
21	255,63	273,1	298,24	315,3	298,24	317,3	340,84	360,4	426,05	453,1	511,26	544,2				
22	267,72	285,3	312,34	329,6	312,34	331,6	356,96	376,7	446,20	473,5	535,44	568,6				
23	279,81	297,5	326,44	343,8	326,44	345,8	373,07	393,0	466,34	493,8	559,61	593,0				
24	291,90	309,7	340,55	358,0	340,55	360,0	389,19	409,3	486,49	514,1	583,79	617,4				
25	303,99	321,9	354,65	372,3	354,65	374,3	405,32	425,5	506,65	534,5	607,98	641,8				
26	316,09	334,1	368,77	386,5	368,77	388,5	421,45	441,8	526,81	554,8	632,17	666,2				
27	328,19	346,2	382,88	400,7	382,88	402,7	437,58	458,0	546,98	575,1	656,37	690,5				
28	340,29	358,4	397,00	414,9	397,00	416,9	453,72	474,3	567,14	595,4	680,57	714,9				
29	352,39	370,6	411,12	429,1	411,12	431,1	469,85	490,5	587,32	615,7	704,78	739,2				
30	364,50	382,8	425,24	443,3	425,24	445,3	485,99	506,7	607,49	636,0	728,99	763,6				
31	376,60	395,0	439,37	457,5	439,37	459,5	502,13	523,0	627,67	656,2	753,20	787,9				
32	388,71	407,1	453,49	471,7	453,49	473,7	518,28	539,2	647,85	676,5	777,42	812,3				
33	400,82	419,3	467,62	485,8	467,62	487,9	534,42	555,4	668,03	696,8	801,63	836,6				
34	412,93	431,4	481,75	500,1	481,75	502,1	550,57	571,6	688,21	717,1	825,86	860,9				
35	425,04	443,6	495,88	514,3	495,88	516,3	566,72	587,8	708,39	737,3	850,07	885,3				
36	437,15	455,8	510,01	528,5	510,01	530,5	582,86	604,0	728,58	757,6	874,30	909,6				
37	449,26	467,9	524,14	542,7	524,14	544,7	599,01	620,3	748,77	777,9	898,52	933,9				
38	461,38	480,1	538,27	556,8	538,27	558,8	615,17	636,5	768,96	798,1	922,75	958,2				
39	473,49	492,2	552,40	571,0	552,40	573,0	631,32	652,7	789,15	818,4	946,98	982,5				
40	485,60	504,4	566,54	585,2	566,54	587,2	647,47	668,9	809,34	838,6	971,21	1007,0				
41	497,72	516,6	580,67	599,4	580,67	601,4	663,63	685,1	829,53	858,9	995,44	1031,0				
42	509,84	528,7	594,81	613,5	594,81	615,5	679,78	701,3	849,73	879,2	1019,67	1055,0				
43	521,95	540,9	608,94	627,7	608,94	629,7	695,93	717,5	869,92	899,4	1043,90	1080,0				
44	534,07	553,0	623,08	641,9	623,08	643,9	712,09	733,7	890,12	919,6	1068,14	1104,0				
45	546,19	565,1	637,22	656,1	637,22	658,1	728,25	749,9	910,31	939,9	1092,37	1128,0				
46	558,31	577,3	651,36	670,2	651,36	672,2	744,41	766,1	930,51	960,1	1116,61	1153,0				
47	570,42	589,4	665,49	684,4	665,49	686,4	760,56	782,3	950,70	980,4	1140,84	1177,0				
48	582,54	601,6	679,63	698,6	679,63	700,6	776,72	798,5	970,90	1000,0	1165,08	1201,0				
49	594,66	613,7	693,77	712,7	693,77	714,7	792,88	814,7	991,10	1021,0	1189,32	1226,0				
50	606,78	625,9	707,91	726,9	707,91	728,9	809,04	830,8	1011,30	1041,0	1213,56	1250,0				
51	618,90	638,0	722,05	741,1	722,05	743,1	825,20	847,0	1031,50	1061,0	1237,80	1274,0				
52	631,02	650,2	736,19	755,2	736,19	757,2	841,36	863,2	1051,70	1082,0	1262,04	1298,0				
53	643,14	662,3	750,33	769,4	750,33	771,4	857,52	879,4	1071,90	1102,0	1286,28	1323,0				
54	655,26	674,4	764,47	783,6	764,47	785,6	873,68	895,6	1092,10	1122,0	1310,52	1347,0				
55	667,38	686,6	778,61	797,7	778,61	799,7	889,84	911,8	1112,30	1142,0	1334,76	1371,0				
56	679,50	698,7	792,75	811,9	792,75	813,9	906,00	928,0	1132,50	1163,0	1359,00	1395,0				
57	691,63	710,9	806,90	826,1	806,90	828,1	922,17	944,2	1152,71	1183,0	1383,25	1420,0				
58	703,75	723,0	821,04	840,2	821,04	842,2	938,33	960,4	1172,91	1203,0	1407,49	1444,0				
59	715,87	735,1	835,18	854,4	835,18	856,4	954,49	976,5	1193,11	1223,0	1431,74	1468,0				
60	727,99	747,3	849,32	868,5	849,32	870,5	970,65	992,7	1213,31	1243,0	1455,98	1493,0				
61	740,11	759,4	863,46	882,7	863,46	884,7	986,82	1009,0	1233,52	1264,0	1480,22	1517,0				
62	752,23	771,6	877,61	896,9	877,61	898,9	1002,97	1025,0	1253,72	1284,0	1504,46	1541,0				
63	764,36	783,7	891,75	911,0	891,75	913,0	1019,14	1041,0	1273,93	1304,0	1528,72	1565,0				
64	776,48	795,8	905,89	925,2	905,89	927,2	1035,30	1057,0	1294,13	1324,0	1552,96	1590,0				
65	788,60	808,0	920,03	939,4	920,03	941,4	1051,47	1074,0	1314,34	1345,0	1577,20	1614,0				
66	800,72	820,1	934,18	953,5	934,18	955,5	1067,63	1090,0	1334,54	1365,0	1601,45	1638,0				
67	812,85	832,3	948,32	967,7	948,32	969,7	1083,80	1106,0	1354,75	1385,0	1625,70	1663,0				
68	824,97	844,4	962,47	981,8	962,47	983,8	1099,96	1122,0	1374,95	1405,0	1649,94	1687,0				
69	837,10	856,5	976,61	996,0	976,61	998,0	1116,13	1138,0	1395,16	1425,0	1674,19	1711,0				
70	849,22	868,6	990,75	1010,0	990,75	1012,0	1132,29	1155,0	1415,36	1445,0	1698,44	1735,0				

All dimensions in mm

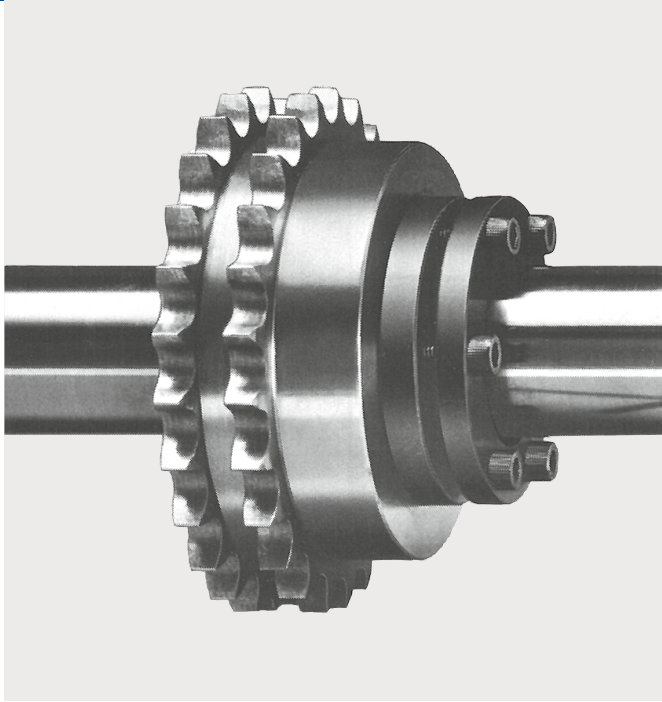

ETP shaft bushings

Friction-locked connection of sprockets and shafts

The ETP shaft bushing is a high-quality clamping element, which mounts components such as sprockets, toothed wheels, levers and other machine parts fast, easily and permanently onto shafts. Grooves, tapers and inside threads are no longer necessary.

Simply slide bushing and hub onto the shaft and tighten the few clamping screws. The only required tool is a simple hexagon wrench. However, a small torque wrench (up to 32 Nm) would be absolutely perfect. The transmissible torques easily exceed the allowable values of the shaft torsional stresses.

Here is an example for a shaft diameter of 40 mm with a feather key connection:

- a) Shaft material St 60: M_d approx. 230 Nm
- b) Shaft material 42 CrMo 4: M_d approx. 310 Nm

The ETP bushing transmits 800 Nm (at 20° Centigrade). Since it is not necessary to mill grooves into the shaft, the shaft diameter can be reduced by max. 25 % (2 x groove depth), i.e. a shaft with a diameter of 30 mm fitted with the proper bushing transmits at least 340 Nm.

This means more efficiency due to:

1. Material savings
2. Lower dimensioning of other components, particularly bearings.

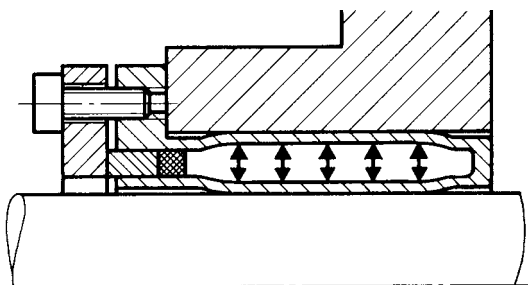

Bushing after tightening of clamping screws

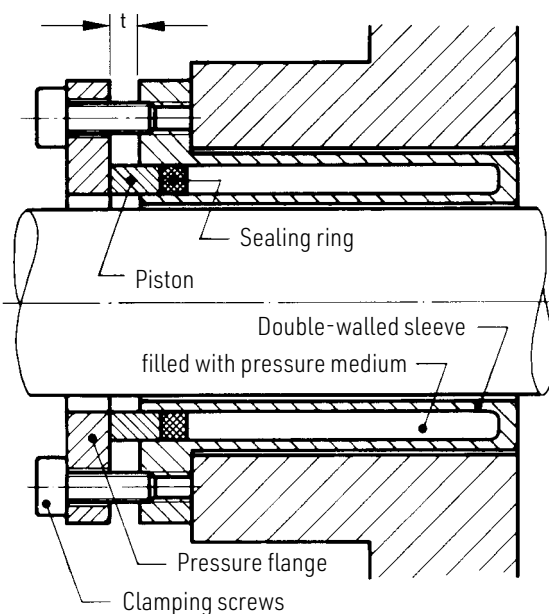

Fine adjustments are possible. Adjusting the transmission elements is never a problem. The bushings are subsequently radially and axially adjustable to change positions without difficulty and backlash-free.

The ETP bushing is easy to repair. There will be no frictional corrosion since micro-movements are prevented due to the solid connection. The bushing can always be re-used, e.g. it can easily be mounted to a new sprocket. Subsequent machining on the old shaft will not be necessary.

The ETP bushing consists of five parts: double-walled sleeve filled with pressure medium, sealing ring, piston, pressure flange and clamping screws (3, 4, 6 or 8 screws).

When the screws are being tightened, the piston forces the pressure medium in the double-walled sleeve against the walls. After tightening the screws with the required clamping torque M_{anz} , almost the entire bushing lies against shaft and hub. Thus the shaft and the respective part it is to be connected to are friction-locked. The pressure medium is resistant to material fatigue, and the clamping force of the bushing will persist. A 100 mm ETP bushing will then be non-slip up to a static moment of at least 12500 Nm. The maximum working temperature is 85°C.

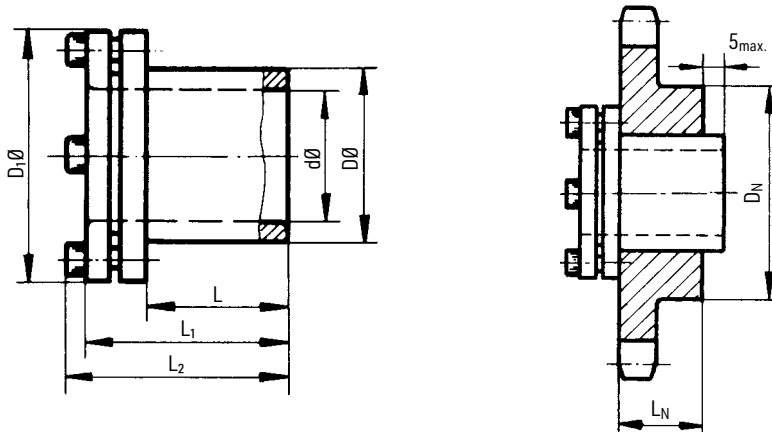

ETP Classic	d	D	D ₁	L	L ₁	L ₂	M _N	F _N	Clamping screws			Weight	Hub Ø min. D _N		Hub length L _N
									Number	Thread	M _{anz.}		Steel	Cast iron	
Order number	mm	mm	mm	mm	mm	mm	Nm	kN	at 20 °C			kg	mm	mm	mm
ETP-15/23-17	15	23	36	17	28	32	43	5,7	3	M4	4,5	0,11	35	46	12
ETP-19/28-21	19	28	45	21	34	39	88	9,3	3	M5	7	0,18	42	56	16
ETP-20/28-22	20	28	45	22	40	45	125	13,0	3	M5	8	0,18	42	56	22
ETP-22/32-22	22	32	49	22	35	40	135	11,6	3	M5	8	0,21	48	64	17
ETP-24/34-25	24	34	49	25	38	43	175	14,4	4	M5	8	0,22	51	68	20
ETP-25/34-27	25	34	49	27	41	46	195	16,2	4	M5	8	0,22	51	68	22
ETP-28/39-29	28	39	55	29	43	48	280	19,5	4	M5	8	0,28	59	78	24
ETP-30/41-32	30	41	57	32	46	51	340	23,1	4	M5	8	0,30	62	82	27
ETP-32/43-34	32	43	60	34	50	55	410	26,1	4	M5	8	0,34	65	86	29
ETP-35/47-37	35	47	63	37	53	58	540	31,1	6	M5	8	0,40	71	94	32
ETP-38/50-41	38	50	65	41	57	62	700	37,4	6	M5	8	0,46	75	100	36
ETP-40/53-43	40	53	70	43	60	65	800	41,3	6	M5	8	0,58	80	106	38
ETP-42/55-45	42	55	70	45	62	67	940	45,4	6	M5	8	0,60	83	110	40
ETP-45/59-49	45	59	77	49	66	72	1180	53,0	6	M6	13	0,75	89	118	44
ETP-48/62-52	48	62	80	52	70	76	1370	59,9	6	M6	13	0,80	93	124	47
ETP-50/65-53	50	65	83	53	72	78	1620	64,8	6	M6	13	0,93	98	130	48
ETP-55/71-58	55	71	88	58	77	83	2110	77,9	8	M6	13	1,10	107	142	53
ETP-60/77-64	60	77	95	64	85	91	2750	93,6	8	M6	13	1,40	116	154	59
ETP-65/84-68	65	84	102	68	90	96	3430	108	8	M6	13	1,73	126	168	63
ETP-70/90-72	70	90	113	72	94	100	4300	124	6	M8	32	1,90	135	180	67
ETP-75/95-85	75	95	118	85	108	114	5300	153	6	M8	32	2,25	143	190	80
ETP-80/100-90	80	100	123	90	114	122	6400	173	6	M8	32	2,62	150	200	85
ETP-85/106-95	85	106	129	95	119	127	7700	194	6	M8	32	3,00	159	212	90
ETP-90/112-100	90	112	135	100	127	135	9100	216	8	M8	32	3,56	168	224	95
ETP-95/120-105	95	120	143	105	132	140	10700	239	8	M8	32	4,39	180	240	100
ETP-100/125-110	100	125	148	110	139	147	12500	264	8	M8	32	4,81	188	250	105

Dimensions, technical specifications and other details were correct at the time of printing, but are subject to change. M_{anz} is the clamping torque of the clamping screws to reach M_N or F_N. F_N is the transmissible axial force at a torque of 0. M_N is the transmissible torque at an axial force of 0.

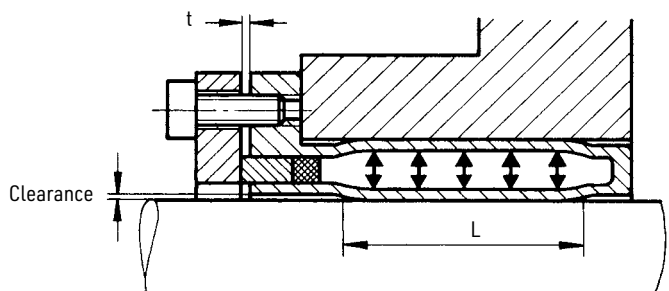

Fit tolerances

ETP bushings have been designed for the following fit tolerances:

Shafts \varnothing h8 - k6 (except 15 mm \varnothing : h7), hub bore hole H7.
Permissible roughness depth: R_a max. = 3 / R_a min. 1 [µm]

Please note: the torque transmission (M) is influenced in a negative way, if the tolerance zone of the bushing connection does not comply with the recommended values. The distance (t) will diminish with increasing clearance. In case of exceedingly high tolerances the pressure flange will connect to the sleeve without the surface pressure required for the torque transmission being reached.

Naben-Dimensionierung

Depending on the material used, the pressure reached at the maximum clamping torque requires a minimum wall thickness of the hub as well as a minimum hub length (see table).

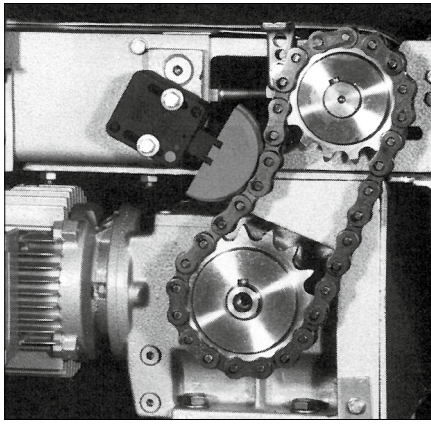

SPANN-BOX® size 0

SPANN-BOX® and SPANN-BOY®

Automatic chain drive tensioning

Not only correct lubrication and wheel alignment, but also chain re-tensioning to compensate for elongation is of crucial importance for a satisfactory life cycle of a chain drive.

Apart from chain tension wheels, our chain tensioners SPANN-BOY® and SPANN-BOX® offer perfect solutions. Due to different sizes and profiles they cover almost all application areas.

For controlling purposes SPANN-BOY® and SPANN-BOX® can be fitted with limit or proximity switches.

We can also supply SPANN-BOY® and SPANN-BOX® with casings or springs made of stainless steel.



SPANN-BOY®



SPANN-BOX® size 1
with deflecting profile



SPANN-BOX® size 1
with arch profile

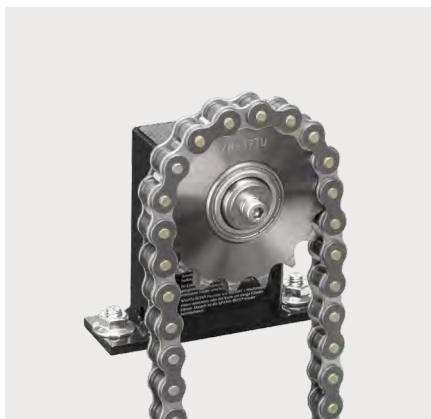

SPANN-BOX® size 1 (type KL)
with sprocket



SPANN-BOX® size 1 (type KS)
with sprocket



SPANN-BOX® size 2
with block profile



Chain No.	Pitch mm	Arch profile				Semicircle profile				Deflecting profile				Block profile				Sprocket															
		Size				SPANN-BOY®				Size				SPANN-BOY®				Size				SPANN-BOY®											
		0	30	1	2					0	30	1	2					0	30	1	2					0	30	1	2				
not mentioned chains with width up to 15 mm						X				X																							
455	9,525		X	X						X		X				X												X				X	
D 455	9,525		X	X			X			X		X				X																	
T 455	9,525		X	X			X			X		X				X																	
462	12,7		X	X			X			X		X				X												X				X	
D 462	12,7		X	X	X		X		X	X		X	X			X	X																
T 462	12,7		X	X	X		X		X	X		X	X			X	X																
501	15,875		X	X			X			X		X				X												X				X	
D 501	15,875		X	X	X		X			X		X	X			X	X																
T 501	15,875		X	X	X		X			X		X	X			X	X																
513	19,05		X	X	X		X		X	X		X	X			X	X											X				X	
D 513	19,05		X	X	X		X			X		X	X			X	X																
T 513	19,05		X	X	X		X			X		X	X			X	X																
548	25,4		X	X	X				X							X	X																
D 548	25,4			X	X																X												
T 548	25,4			X	X																X												
563	31,75			X	X																												
D 563	31,75				X																X												
T 563	31,75				X																X												
596	38,1				X																X												
D 596	38,1				X																X												
T 596	38,1																				X												
613	44,45																				X												
D 613	44,45																				X												
T 613	44,45																				X												
652	50,8																				X												
D 652	50,8																				X												
T 652	50,8																				X												
671	63,5																				X												
D 671	63,5																				X												
T 671	63,5																				X												
679	76,2																				X												
D 679	76,2																				X												
T 679	76,2																				X												

Tension values and range of shift

Size	SPANN-BOY®		SPANN-BOX® size 0		SPANN-BOX® size 30 or 1		SPANN-BOX® size 2	
Range of shift	40 mm		40 mm		40 mm		60 mm	
Spring Design	light	heavy	light	heavy	light	heavy	light	heavy
Tension force	N	N	N	N	N	N	N	N
1 spring released	58 - 32	132 - 60	58 - 32	132 - 60	58 - 32	132 - 60	148 - 82	262 - 116
2 springs released	-	-	-	-	116 - 64	264 - 120	296 - 164	524 - 236
3 springs released	-	-	-	-	174 - 96	396 - 180	444 - 246	786 - 454

The chain weight should not be higher than the force of a spring already released by 50%.
The second and the third spring may be activated later if required.

Further combinations and profiles made to specification are also available.



SPANN-BOX® size 0

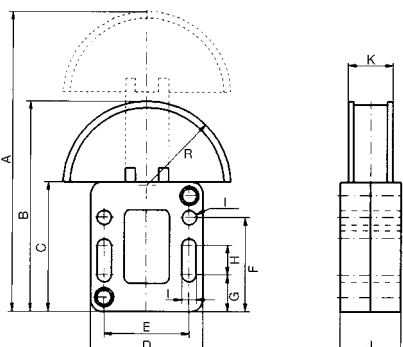

SPANN-BOX® size 30 with arch profile

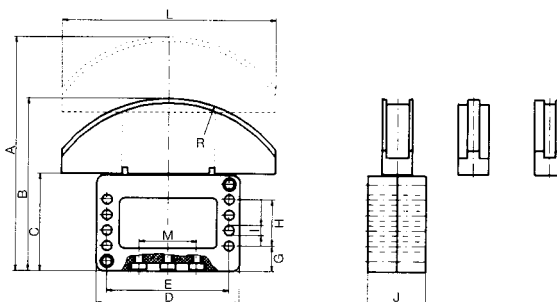

SPANN-BOX® size 1 and 2 with arch profile

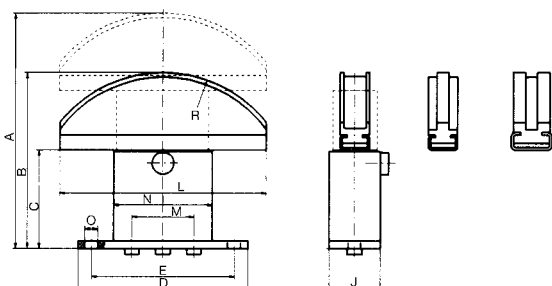

SPANN-BOX® size 1 and 2 with deflecting profile

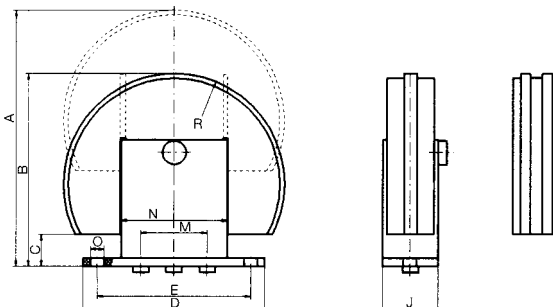

SPANN-BOX® size 1 and 2 with semicircle profile

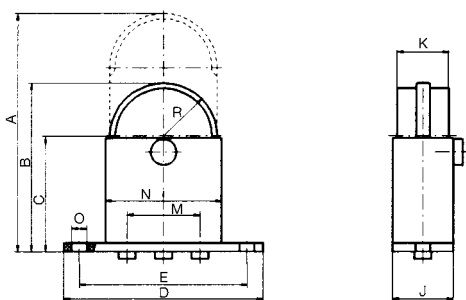

SPANN-BOX® size 2 with block profile

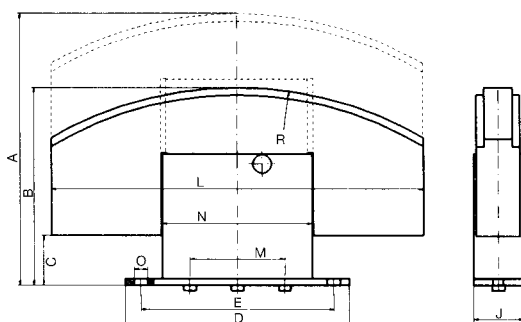

Dimensions	Ind.	A	B	C	D	E	F	G	H	I	J	K	L	M	N	O	R
Size 0		134,0	94,0	58,0	50	38	42	16,2	12,9	6,5	27	20	-	-	-	-	37,5
Size 30		152,5	112,5	63,5	94	80	-	16,5	30,0	6,5	38	-	140	38	-	-	90,0
Size 1, arch profile		158,0	118,0	66,0	115	97	-	-	-	-	35	-	140	42	67	8,5	90,0
Size 1, arch profile	*	173,0	133,0	81,0	115	97	-	-	-	-	40	-	140	42	67	8,5	90,0
Size 1, semicircle profile		137,0	97,0	66,0	115	97	-	-	-	-	35	30	-	42	67	8,5	31,0
Size 1, semicircle profile	*	152,0	112,0	81,0	115	97	-	-	-	-	40	30	-	42	67	8,5	31,0
Size 1, deflecting profile		162,0	122,0	20,0	115	97	-	-	-	-	35	-	-	42	67	8,5	70,0
Size 2, arch profile		209,0	149,0	86,0	180	155	-	-	-	-	40	-	200	76	120	11,0	150,0
Size 2, arch profile	*	229,0	169,0	106,0	180	155	-	-	-	-	40	-	200	76	120	11,0	150,0
Size 2, semicircle profile		203,0	143,0	86,0	180	155	-	-	-	-	40	35	-	76	120	11,0	57,0
Size 2, semicircle profile	*	223,0	163,0	106,0	180	155	-	-	-	-	40	35	-	76	120	11,0	57,0
Size 2, deflecting profile		225,0	165,0	40,0	180	155	-	-	-	-	40	-	-	76	120	11,0	100,0
Size 2, block profile		218,0	158,0	40,0	180	155	-	-	-	-	40	-	300	76	120	11,0	300,0

* long casing

SPANN-BOX® Size 1 with sprocket type KL

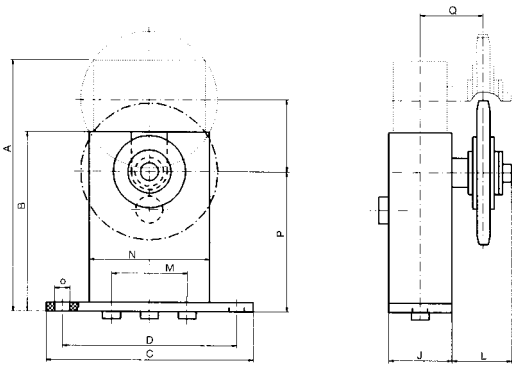

SPANN-BOX® Size 1 with sprocket type KS

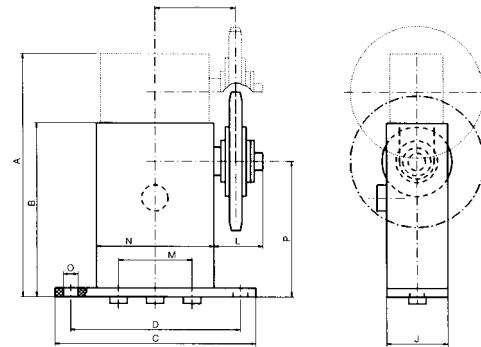

SPANN-BOY® with arch profile

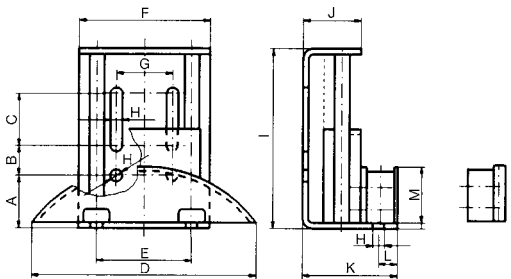

SPANN-BOY® with sprocket

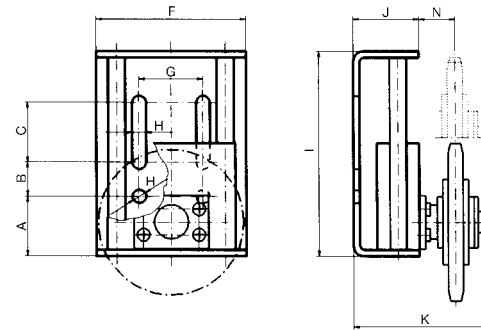

Mounting bracket for SPANN-BOX® size 1 and 2

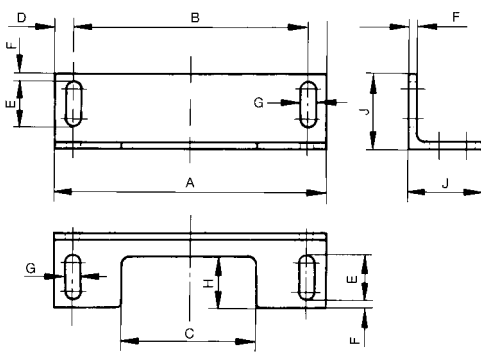

Standard sprockets

Chain-No.	Number of teeth			
	20	21	23	
455	20	21	23	
462	16	17	18	
501	14	15	16	17
513	13	15	16	17

Dimensions	A	B	C	D	E	F	G	H	I	J	K	L	M	N	O	P	Q
SPANN-BOX® size 1 (type KL)	140	100	115	97,0	-	-	-	-	-	35	8,5	35 max.	42	67	8,5	78	35
SPANN-BOX® size 1 (type KS)	140	100	115	97,0	-	-	-	-	-	35	8,5	30 max.	42	67	8,5	78	46
Bracket size 1	115	97	60	9,0	25,0	5	8,5	30,0	-	45	-	-	-	-	-	-	-
Bracket size 2	180	155	90	12,5	30,0	5	11,0	35,0	-	50	-	-	-	-	-	-	-
SPANN-BOY® (arch profile)	28	16	28	120,0	50,8	70	30,0	6,4	96	31	51,0	10	30	-	-	-	-
SPANN-BOY® (with sprocket)	28	16	28	-	-	70	30,0	6,4	96	31	66,0 max.	-	-	17	-	-	-

SPANN-BOX® and mounting brackets made of stainless steel grade 1.4301 on request (Please note: different sizes!).



Slide rails made of polyethylene material

Steel C-profile max. 6000 mm long, split S-profile 2000 mm each

Type CK

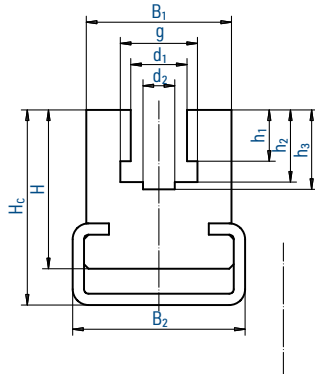

Type CKG

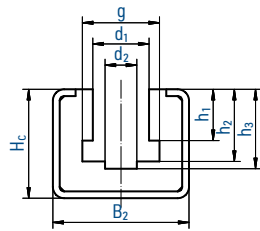

Type CKG 14H

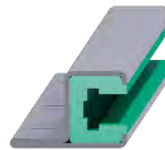
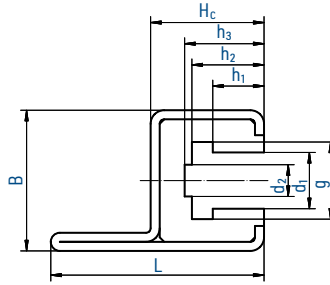

Type CKG 15V

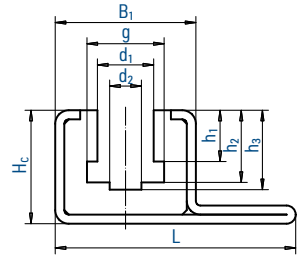

Chain			Type	C-profile sendzimir galvanized	Standard dimensions											
No.	Ind.	ISO No.			B	B ₁	B ₂	H	H _c	L	d ₁	d ₂	g	h ₁	h ₂	h ₃
					mm	mm	mm	mm	mm	mm	mm	mm	mm	mm	mm	mm
CK	455	06B-1	CK3	C3	-	20	20	18	21	-	6,6	4	9,4	5,5	8,9	10,0
	462	08B-1	CK7	C7	-	28	28	28	32	-	8,9	5	12,8	7,4	11,5	13,0
	501	10B-1	CK7	C7	-	28	28	28	32	-	10,6	6	15,4	9,3	13,5	14,9
	513	12B-1	CK9	C9	-	38	38	35	43	-	12,4	7	17,0	11,3	15,9	17,5
	548	16B-1	CK9	C9	-	38	38	45	50	-	16,4	10	24,0	16,0	25,7	27,7
	583	20B-1	CK12	C12	-	60	60	50	55	-	20,0	11	28,0	18,0	29,5	31,7
	596	24B-1	CK12	C12	-	60	60	60	65	-	27,0	16	36,6	24,0	38,2	41,2
CKG	613	28B-1	CK13	C12	-	75	60	75	80	-	30,0	17	40,0	30,0	47,0	49,0
	652	32B-1	CK14	C12	-	75	60	75	80	-	31,0	19	44,6	30,0	47,3	50,0
	455	06B-1	CKG 10	C10	-	-	30	-	24	-	6,6	4	9,4	5,5	8,9	10,0
	462	08B-1	CKG 10	C10	-	-	30	-	24	-	8,9	5	12,8	7,4	11,5	13,0
	501	10B-1	CKG 10	C10	-	-	30	-	24	-	10,6	6	15,4	9,3	13,5	14,9
	513	12B-1	CKG 10	C10	-	-	30	-	24	-	12,4	7	17,0	11,3	15,9	17,5
	548	16B-1	CKG 11	C11	-	-	45	-	40	-	16,4	10	24,0	16,0	25,7	27,7
CKG 14H	563	20B-1	CKG 11	C11	-	-	45	-	40	-	20,0	11	28,0	18,0	29,5	31,7
	596	24B-1	CKG 13	C13	-	-	65	-	55	-	27,0	16	36,6	24,0	38,2	41,2
	613	28B-1	CKG 13	C13	-	-	65	-	55	-	30,0	17	41,0	30,0	47,0	49,0
	652	32B-1	CKG 13	C13	-	-	65	-	60	-	31,0	19	44,6	30,0	47,3	50,0
	455	06B-1	CKG 14H	C14H	31	-	-	-	25	47	6,6	-	9,4	5,5	8,9	10,0
CKV 15V	462	08B-1	CKG 14H	C14H	31	-	-	-	25	47	8,9	-	12,8	7,4	11,5	13,0
	501	10B-1	CKG 14H	C14H	31	-	-	-	25	47	10,6	-	15,4	9,3	13,5	14,9
	513	12B-1	CKG 14H	C14H	31	-	-	-	25	47	12,4	-	17,0	11,3	15,9	17,5
	455	06B-1	CKG 15V	C15V	31	-	-	-	25	53	6,6	-	9,4	5,5	8,9	10,0
CKV 15V	462	08B-1	CKG 15V	C15V	31	-	-	-	25	53	8,9	-	12,8	7,4	11,5	13,0
	501	10B-1	CKG 15V	C15V	31	-	-	-	25	53	10,6	-	15,4	9,3	13,5	14,9
	513	12B-1	CKG 15V	C15V	31	-	-	-	25	53	12,4	-	17,0	11,3	15,9	17,5

Stainless steel version on request.

Also available in other designs and with different H dimensions.



Type CT

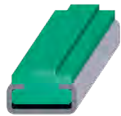
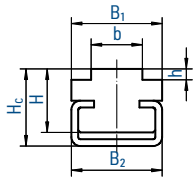

Type CTS

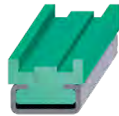
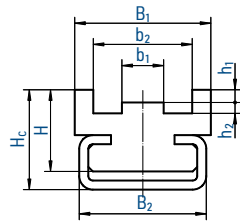

Type CT Duplex

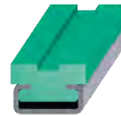
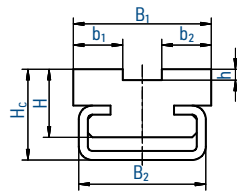

Type CU

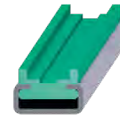
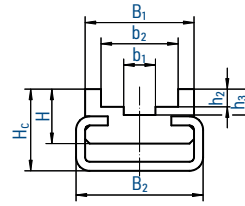

Type ETA

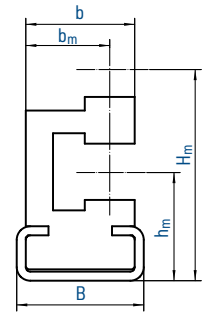

Chain			Type	C-profile	Standard dimensions															
	ISO				B	B ₁	B ₂	H	H _c	H _m	d ₂	g	b	b ₁	b ₂	b _m	h	h ₁	h ₂	h ₃
No.	Ind.	No.		mm	mm	mm	mm	mm	mm	mm	mm	mm	mm	mm	mm	mm	mm	mm	mm	mm
CT	455	06B-1	CT 3H15	C3	-	17,0	20	14	17	-	-	-	5,4	-	-	-	1,5	-	-	-
	462	08B-1	CT 3H10	C3	-	17,0	20	14	17	-	-	-	7,4	-	-	-	2,2	-	-	-
	501	10B-1	CT 3H15	C3	-	17,0	20	14	17	-	-	-	9,3	-	-	-	2,6	-	-	-
	513	12B-1	CT 3H15	C3	-	20,0	20	14	17	-	-	-	11,3	-	-	-	2,4	-	-	-
	548	16B-1	CT 3H15	C5	-	24,0	28	14	18	-	-	-	16,0	-	-	-	3,5	-	-	-
	563	20B-1	CT 3H15	C5	-	28,0	28	14	18	-	-	-	18,0	-	-	-	4,2	-	-	-
	596	24B-1	CT 9H25	C9	-	33,0	38	23	30	-	-	-	24,0	-	-	-	5,5	-	-	-
	613	28B-1	CT 9H25	C9	-	38,0	38	23	30	-	-	-	30,0	-	-	-	6,8	-	-	-
	652	32B-1	CT 9H25	C9	-	38,0	38	23	30	-	-	-	30,0	-	-	-	7,7	-	-	-
	671	38B-1	CT 12H25	C12	-	60,0	60	25	35	-	-	-	30,0	-	-	-	7,7	-	-	-
CTS	455	06B-1	CTS 1	C3	-	20,0	20	14	17	-	-	-	-	3,8	13,0	-	-	1,5	1,1	-
	462	08B-1	CTS 4	C3	-	25,0	20	16	20	-	-	-	-	5,7	16,3	-	-	2,2	1,6	-
	501	10B-1	CTS 6	C5	-	28,0	28	16	20	-	-	-	-	7,4	19,2	-	-	2,6	2,1	-
	513	12B-1	CTS 7	C5	-	30,0	28	18	22	-	-	-	-	9,2	21,8	-	-	2,4	2,8	-
	548	16B-1	CTS 8	C9	-	42,0	38	25	30	-	-	-	-	15,0	33,8	-	-	3,5	3,3	-
	563	20B-1	CTS 9	C9	-	50,0	38	30	35	-	-	-	-	16,8	40,0	-	-	4,2	4,0	-
CT Duplex	D 455	06B-1	CT 3H15	C3	-	15,7	20	14	17	-	-	-	-	5,5	-	-	-	1,5	-	-
	D 462	08B-1	CT 3H15	C3	-	21,2	20	14	17	-	-	-	-	7,4	-	-	-	2,2	-	-
	D 501	10B-1	CT 3H15	C3	-	25,7	20	14	17	-	-	-	-	9,3	-	-	-	2,6	-	-
	D 513	12B-1	CT 5H15	C5	-	30,7	28	15	20	-	-	-	-	11,3	-	-	-	2,4	-	-
	D 548	16B-1	CT 9H20	C9	-	48,0	38	20	27	-	-	-	-	16,0	-	-	-	3,5	-	-
	D 563	20B-1	CT 12H25	C12	-	55,0	60	22	30	-	-	-	-	18,0	-	-	-	4,2	-	-
CU	455	06B-1	CU 3H15	C3	-	20,0	20	14	17	-	4	9,4	-	-	-	-	-	2,8	4,2	-
	462	08B-1	CU 1H10	C1	-	20,0	24	10	11	-	5	12,8	-	-	-	-	-	3,5	5,0	-
	501	10B-1	CU 5H12	C5	-	24,0	28	12	18	-	6	15,4	-	-	-	-	-	3,6	5,0	-
	513	12B-1	CU 5H12	C5	-	24,0	28	12	18	-	7	17,0	-	-	-	-	-	3,9	5,7	-
	548	16B-1	CU 9H20	C9	-	33,0	38	20	30	-	10	24,0	-	-	-	-	-	8,4	10,6	-
	563	20B-1	CU 12H25	C12	-	60,0	60	25	35	-	11	28,0	-	-	-	-	-	10,0	12,2	-
	596	24B-1	CU 12H30	C12	-	60,0	60	30	40	-	16	36,6	-	-	-	-	-	13,0	16,0	-
	613	28B-1	CU 12H40	C12	-	65,0	60	38	45	-	17	40,0	-	-	-	-	-	16,0	18,0	-
	652	32B-1	CU 12H40	C12	-	70,0	60	38	45	-	19	44,6	-	-	-	-	-	16,0	18,7	-
	ETA	455	06B-1	ETA 0	C3	20	-	-	-	-	30,2	-	-	17,0	-	-	14,5	-	-	-
462		08B-1	ETA 1	C3	20	-	-	-	-	33,8	-	-	20,0	-	-	16,5	-	-	-	18
501		10B-1	ETA 2	C3	20	-	-	-	-	41,1	-	-	20,0	-	-	15,5	-	-	-	21
513		12B-1	ETA 3	C5	28	-	-	-	-	46,5	-	-	24,0	-	-	18,5	-	-	-	24
548		16B-1	ETA 4	C9	38	-	-	-	-	62,0	-	-	33,0	-	-	25,0	-	-	-	34

Stainless steel version on request.
Also available in other designs and with different H dimensions.



Slide rails made of polyethylene material

Slide rail length 2000 mm; cuttings are charged at full meter prices, plus cutting costs

Type T

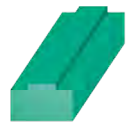
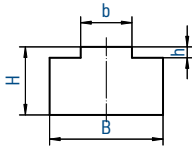

Type TS

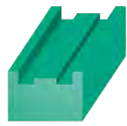
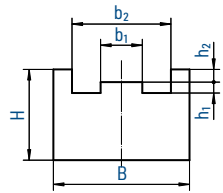

Type T Duplex

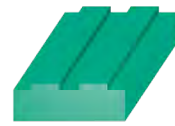
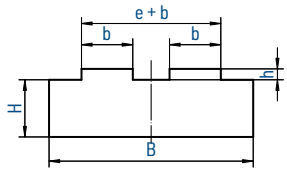

Type U

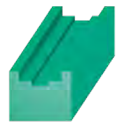
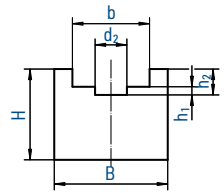

Type K

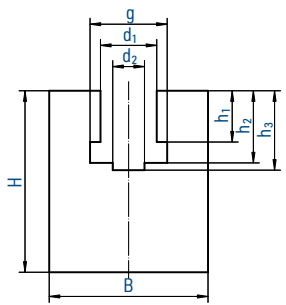

Chain			Type	Standard dimensions												
	ISO			B	H	b	b ₁	b ₂	d ₁	d ₂	g	h	h ₁	h ₂	h ₃	e+b
Nr.	Ind.	Nr.		mm	mm	mm	mm	mm	mm	mm	mm	mm	mm	mm	mm	
T	455		06B-1	T	15	10	5,4	-	-	-	-	1,5	-	-	-	-
	462		08B-1	T1	20	10	7,4	-	-	-	-	2,2	-	-	-	-
	501		10B-1	T2	20	10	9,3	-	-	-	-	2,6	-	-	-	-
	513		12B-1	T3	25	15	11,3	-	-	-	-	2,4	-	-	-	-
	548		16B-1	T4	40	15	16,0	-	-	-	-	3,5	-	-	-	-
	563		20B-1	T5	45	15	18,0	-	-	-	-	4,2	-	-	-	-
	596		24B-1	T6	60	15	24,0	-	-	-	-	5,5	-	-	-	-
	613		28B-1	T7	75	20	30,0	-	-	-	-	6,8	-	-	-	-
	652		32B-1	T8	80	20	30,0	-	-	-	-	7,7	-	-	-	-
TS	455		06B-1	TS1	20	10	-	3,8	13,0	-	-	1,5	1,5	1,1	-	-
	462		08B-1	TS4	25	15	-	5,7	16,3	-	-	2,2	2,2	1,6	-	-
	501		10B-1	TS6	28	15	-	7,4	19,2	-	-	2,6	2,6	2,1	-	-
	513		12B-1	TS7	30	20	-	9,2	21,8	-	-	2,4	2,4	2,8	-	-
	548		16B-1	TS8	42	25	-	15,0	33,8	-	-	3,5	3,5	3,3	-	-
	563		20B-1	TS9	50	25	-	16,8	40,0	-	-	4,2	4,2	4,0	-	-
T Duplex D	455		06B-2	T	25	10	5,4	-	-	-	-	5,5	-	-	-	15,6
	D 462		08B-2	T1.2	35	10	7,4	-	-	-	-	6,8	-	-	-	21,2
	D 501		10B-2	T2.2	40	10	9,3	-	-	-	-	7,7	-	-	-	25,7
	D 513		12B-2	T3.2	45	15	11,3	-	-	-	-	-	-	-	-	30,7
	D 548		16B-2	T4.2	48	15	16,0	-	-	-	-	-	-	-	-	48,0
	D 563		20B-2	T5.2	55	15	18,0	-	-	-	-	-	-	-	-	55,0
	D 596		24B-2	T6.2	72	20	24,0	-	-	-	-	-	-	-	-	72,0
	D 613		28B-2	T7.2	89	25	30,0	-	-	-	-	-	-	-	-	89,0
	D 652		32B-2	T8.2	88	30	30,0	-	-	-	-	-	-	-	-	88,0
U	455		06B-1	U	20	15	-	-	-	4	9,4	-	-	2,8	4,2	-
	462		08B-1	U	25	15	-	-	-	5	12,8	-	-	3,5	5,0	-
	501		10B-1	U2	25	15	-	-	-	6	15,4	-	-	3,6	5,0	-
	513		12B-1	U3	25	20	-	-	-	7	17,0	-	-	3,9	5,7	-
	548		16B-1	U4	35	25	-	-	-	10	24,0	-	-	8,4	10,6	-
	563		20B-1	U5	55	25	-	-	-	11	28,0	-	-	10,0	12,2	-
	596		24B-1	U6	60	30	-	-	-	16	36,6	-	-	13,0	16,0	-
	613		28B-1	U7	65	30	-	-	-	17	40,0	-	-	16,0	18,0	-
	652		32B-1	U8	70	30	-	-	-	19	44,6	-	-	16,0	18,7	-
K	455		06B-1	K	20	25	-	-	6,6	4	9,4	-	5,5	8,9	10,0	-
	462		08B-1	K1	24	30	-	-	8,9	5	12,8	-	7,4	11,5	13,0	-
	501		10B-1	K2	30	35	-	-	10,6	6	15,4	-	9,3	13,5	14,9	-
	513		12B-1	K3	40	35	-	-	12,4	7	17,0	-	11,3	15,9	17,5	-
	548		16B-1	K4	40	45	-	-	16,4	10	24,0	-	16,0	25,7	27,0	-
	563		20B-1	K5	50	50	-	-	20,0	11	28,0	-	18,0	29,5	31,7	-
	596		24B-1	K6	60	60	-	-	27,0	16	36,6	-	24,0	38,2	41,2	-
	613		28B-1	K7	60	70	-	-	30,0	17	41,0	-	30,0	47,0	49,0	-
	652		32B-1	K8	70	75	-	-	31,0	19	44,6	-	30,0	47,3	50,0	-

Stainless steel version on request. Also available in other designs and with different H dimensions.

The followings aspects should be considered when selecting a lubricant:

- **Oil or grease lubrication**
Oils are normally used for continuous relubrication. Grease is preferred, if the ambient air contains dust (lime, talcum, flour etc.).
- **Operating temperature**
This is one of the most significant aspects of lubricant selection. The decisive criterion is the temperature in the chain bearing during operation.
- **Viscosity**
Viscosity must be high enough so that all the chain parts are protected against wear and galling. However, despite high viscosity the oil must be sufficiently capable of flow.
The following rules of thumb apply:
 - Low bearing pressure, high chain speed = low viscosity
 - High bearing pressure, low chain speed = high viscosity
 - Low operating temperature = low viscosity
 - High operating temperature = high viscosity
- **Initial lubricant**
It must have excellent corrosion protection qualities and guarantee sufficient wear protection up to the first relubrication. The envisaged operating conditions should be taken into account.
- **Load-bearing properties**
Sufficient load-bearing properties of the lubricating oil film help to reduce wear.
- **Friction point wetting**
The chain lubricant must be able to permeate the lubrication gap autonomously.
- **Chain cooling**
In conjunction with appropriate lubrication procedures certain oils are suitable for cooling. The maximum service temperature of the lubricating oil must never be exceeded.
- **Applications in the food industry**
Lubricants must comply with specific food law requirements.
- **Applications in the textile industry**
Non-drip and non-adhesive oils should be used.
- **Corrosion protection**
This is particularly important for chains used in corrosive environments.
- **Applications in wet environments**
Lubricants must not be washed off by splash water. They must be capable of creep, and supply sufficient corrosion protection even as emulsions.
- **Muffling of chain noises**
Lubricants with higher viscosity ensure better muffling properties than low viscosity lubricants. However, the lubricants must always be sufficiently capable of flow.

- **Contact with elastomers and synthetic materials**
Compatibility with elastomers and synthetic materials must be guaranteed. Compatibility tests are always required.
- **Lifetime lubrication**
Lubrication has been designed in a way that the lubricant will be functioning during the entire lifetime of the chain.
- **Lifetime lubrication for chains is possible, if**
 - the chain load is low
 - the service temperature of the lubricant is considerably underrun
 - the overall operating time is low
 For lifetime lubrication special non-aging chain lubricants have been developed.
- **Ground water hazards**
Please refer to the appropriate safety data specifications.
- **General environmental compatibility**
Please use lubricants, which are biodegradable and particularly environmentally friendly.

Chain lubrication from production to operation

Chain manufacturers	Initial lubrication Corrosion and wear protection Selection of suitable lubrication method
Machine/engine manufacturers	Make already installed chains accessible for manual lubrication Plan chain protection boxes Provide oil pans Design lubrication facilities State reference values for lubrication schedules and lubricant dosage
Machine/engine operators	Inspection of lubrication state and, if necessary, evaluation of lubrication schedules and lubricant dosage Chain cleansing Chain conservation Relubrication

Performance of roller chains as a function of temperature

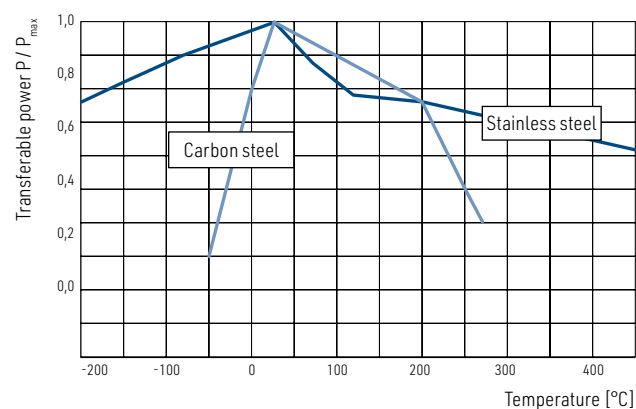

Also refer to the chapter "Maintenance of chain drives" on page 150.



General information

Chains running on sprockets are subject to wear of the joints due to angle-sliding movements of the pins. Therefore efficient lubrication is of utmost importance. Even low-maintenance roller chains with plastic slide bearings should be relubricated occasionally.

Dry running condition (curve 1) causes excessive wear and destroys the chain within a very short time.

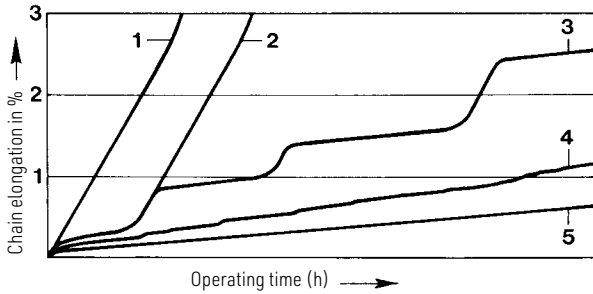

Chain elongation as a function of operating time with different lubrication states

One-time lubrication (curve 2) only delays the wear until the lubricant has been used up.

Intermittent dry running conditions (curve 3) frequently occur with manual lubrication, particularly if deadlines for relubrication have not been met.

Wrong lubrication (curve 4) results in uneven wear and may be caused by inferior, dirty, wrong (unsuitable viscosity) or too little lubricant.

Correct lubrication (curve 5) is crucial for chain drives according to performance diagrams.

Lubrication and degree of efficiency

The following graph shows the influence of lubrication on efficiency.

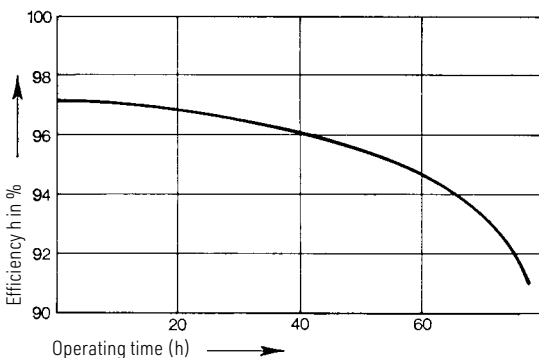

Degree of efficiency as a function of operating time with one-time lubrication (according to Worobjew)

Lubricants

The selection of an appropriate lubricant depends first of all on the type of lubrication.

Low viscosity mineral oils are particularly suitable for chain drives.

Ambient temperature °C	Viscosity group of lubricant
- 5 bis + 25	ISO VG 100 (SAE 30)
25 bis 45	ISOVG 150 (SAE 40)
45 bis 65	ISOVG 220 (SAE 50)

For higher temperatures (e.g. furnace chains) graphite or molybdenum disulfide (MoS₂) applied either as additive or spray will facilitate lubrication.

Low-viscosity or hardened grease products with a drop point of 70° C are also suitable for manual lubrication. In special cases liquidised grease may be sprayed on. Initial operation can start immediately after evaporation of the volatile carrier substance.

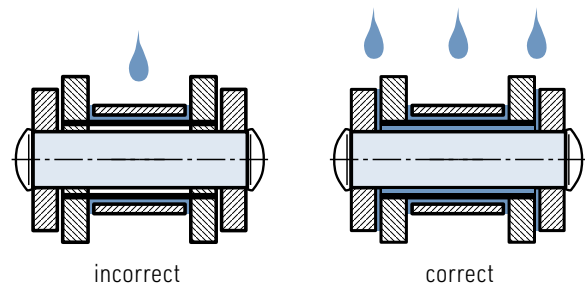

It is very important that the lubricant reaches the joints (pins, bushings), which are subject to wear.

Recommendations for lubrication

The type of lubrication depends on the chain pitch and the chain speed.

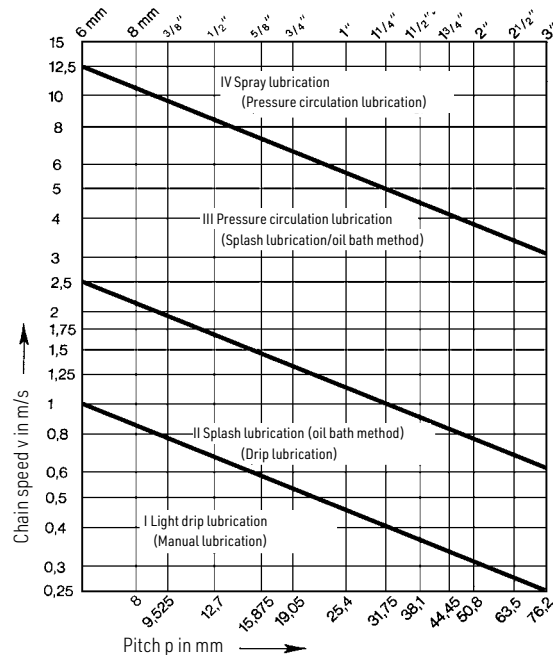

The lubrication types, which are not in brackets, are preferable to those in brackets (permitted).

In order to achieve a long wear life and high cost effectiveness for chain drives in lubrication range I (light drip lubrication or manual lubrication) relubrication schedules must be determined by tests.



Manual lubrication

This type of lubrication by means of oil can and brush is not very safe and therefore only suitable for chains with occasional operation or for secondary drives and low chain speeds.

Sufficient lubrication should take place at least once a day (if possible every 8 operating hours). Lubricant colouration may not occur.

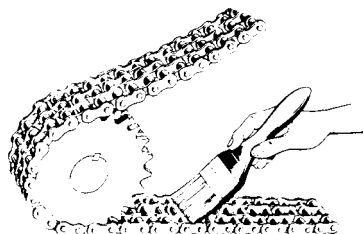

Spinning disk lubrication

With this type of lubrication the chain operates above oil level. A disk submerging into the lower oil level (peripheral velocity between min. and max. 40 m/s) centrifuges oil against the casing walls from where it continuously runs down onto the chain via drip rails.

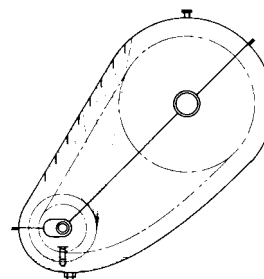

Splash lubrication (oil bath method)

There is just enough oil in a sufficiently sized protection box (the worn and elongated chain must not be able to hit against the casing wall) to allow the chain plates to submerge into the bath up to the rollers or the bushings respectively.

Higher submerging depths cause the oil to heat up and lead to untimely oxidation of the oil.

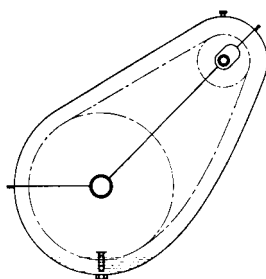

Spray lubrication

Spray lubrication is very similar to pressure circulation lubrication. Instead of a lubrication shower, however, lubrication spray valves atomise the oil into aerosol form, and thus the fine oil mist can reach every single chain joint.

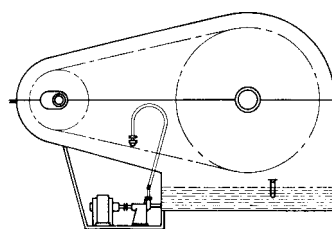

Drip lubrication

Drip lubrication by means of wick oilers, needle oilers or drip oilers is only suitable for low load bearing drives. Sufficient lubrication of the joint surfaces must be ensured. Lubricant colouration may not occur.

Pressure circulation lubrication

This type of lubrication is suitable for fast-running drives and high loads. The oil can be supplied via a connection to an existing pressure oil pipe or via an extra pump. By means of a lubrication shower situated near the large sprocket, oil is sprayed onto the inner side of the chain return strand in running direction over the whole width of the chain. High load-bearing drives need a second shower for cooling with the oil to be sprayed onto the pull strand. The oil quantity depends on the drive size and the amount of heat to be dissipated.

Lubrication overview

Lubrication range	Chain speed m/s	Lubrication a) favourable b) permitted	Transmissible power			
			correct lubrication (favourable/permitted)	insufficient lubrication without contamination	insufficient lubrication with contamination	without lubrication*
I	up to ≈ 1	a) Light drip lubrication b) Manual lubrication/grease lubrication	100 %	60 %	30 %	15 %
II	up to ≈2,5	a) Splash lubrication (oil bath method) b) Drip lubrication		30 %	15 %	
III	up to ≈12,5	a) Pressure circulation lubrication b) Splash lubrication (oil bath method), if possible with spinning disk		not permitted		
IV	above 12,5	a) Spray lubrication b) Pressure circulation lubrication (possibly with oil cooling system)				

* a wear life of 15 000 hours cannot be guaranteed!



WKS Sprays

In addition to the application-specific design of our chains, the use of the right lubricant also plays a decisive role for wear resistance and therefore for the lifespan of your drive system.

We therefore offer our high-performance WKS lubricants for every application, including relubrication, in addition to the initial lubrication of our chains.



The Wippermann range of products not only offers the versatile WKS chain sprays, but also includes over 30 high-quality lubricants for every application. WKS-Plus, WKS-Spezial and WKS-H1 are also available in 5 liter containers for use in lubrication systems.

The advantages of the WKS chain sprays

- Suitable for relubrication of all drive, control, conveyor and lifting chains
- Sustainably reduces joint wear and chain elongation
- Optimum corrosion protection
- Spray can with an extended spray head for precise handling with low spray loss

Application tips for effective use

- Spray distance about 20 cm
- Targeted spraying of the joint spaces for optimum supply of bolts and bushes with lubricant

Product	Properties	Area of application
WKS-C 500 ml 	<ul style="list-style-type: none"> • Water-repellent and particularly suitable for corrosive environments • High adhesive strength, non-dripping, good creep capability • Excellent corrosion protection • Significant reduction of aging and wear processes • Removes old crusted and cracked residues • No known adverse interactions with other materials 	<ul style="list-style-type: none"> • - 10 °C to +100 °C • Lubrication of drive, control, lifting and transport chains • Use in maritime, industrial or agricultural plants • Suitable for relubrication of mineral oil base initial lubrications • Can also be sprayed overhead
WKS-Plus 400 ml 	<ul style="list-style-type: none"> • High adhesive strength, nondripping, good creep capability under high temperatures • Removal of varnished and cracked residues • Corrosion protection • Reduction of aging and wear processes • Low residue forming without gumming and varnishing • Temperature stability and aging resistance • High paint compatibility • Physiologically safe according to the regulations of the German Food and Feed Code (LFGB) 	<ul style="list-style-type: none"> • - 10 °C to +240 °C • Lubrication of drive, control and transport chains • Use in hot environments, such as paint dryers in the automotive industry, shrink tunnels in the food industry, tenter frames in the textile industry or transport chains in circular conveyors • Relubrication of mineral oil base initial lubrications after prior inspection • Can also be sprayed overhead
WKS-Spezial 500 ml 	<ul style="list-style-type: none"> • Good adhesive strength and creep capability • Removal of old crusted and cracked residues • Good corrosion protection • Reduction of aging and wear processes • Not suitable for moist environments • No known adverse interactions with other materials 	<ul style="list-style-type: none"> • - 10 °C to +80 °C • Lubrication of drive, conveyor and lifting chains • Industrial and agricultural plants and machinery • Relubrication of mineral oil base initial lubrications • Can also be sprayed overhead

All lubricants distributed by WIPPERMANN are chlorine- and silicone-free.

WIPPERMANN Lubricants

Product	Oil	Grease	Spray	Application °C from to	Technical features
WKS-C				- 10 + 100	<p>WIPPERMANN standard lubrication</p> <ul style="list-style-type: none"> WIPPERMANN standard lubrication Mineral oil-based, soap-free chain grease with waxes and product-specific additives for extreme requirements regarding corrosion and wear protection Water-repellent
WKS-C Spray				- 10 + 100	<p>WIPPERMANN Standard lubrication spray</p> <ul style="list-style-type: none"> As relubrication for WKS-C initial lubrication High-performance chain spray for outstanding results with regard to wear protection, adhesion and care Water-repellent and therefore the optimum solution in corrosive environments
WKS-W				0 + 80	<p>Lubrication wax for chains</p> <ul style="list-style-type: none"> "Quasi-dry" non-sticky lubrication film Wear protection High corrosion protection Good adhesive properties Excellent water resistance
WKS-D				- 10 + 80	<p>Corrosion protection oil</p> <ul style="list-style-type: none"> Chlorine-free lubricant made from mineral oil raffinates and corrosion protection additives; thin, waxy and pressure-resistant lubricating film with anti-wear additives Excellent corrosion protection
WKS-H1				- 10 + 140	<p>Chain lubricant for hygienic and clean lubrication</p> <ul style="list-style-type: none"> Fully synthetic high-performance chain lubricant for the pharmaceutical, food and beverage, cosmetics, animal feed and tobacco industries as well as their suppliers Complies with the requirements of Title 21 of the Code of Federal Regulations (regulations of the FDA) Increased performance range achieved by a combination of high-quality, mineral oil-free synthetic base oils with a high-capacity additives package. <u>Nonfood Compounds Program Listed H1, NSF Reg # 143954</u>
WKS-Plus				- 10 + 240	<p>High-temperature lubricant</p> <ul style="list-style-type: none"> Fully synthetic, temperature-stable high-performance oil, specially developed for chain lubrication Improved protection against wear, aging and corrosion due to a combination of synthetic ester oils and additives This product combines the special requirements of chain lubrication with the demands on paint compatibility.
WKS-Plus Spray				- 10 + 240	<p>High-temperature chain spray</p> <ul style="list-style-type: none"> The optimum solution for the use in high-temperature environments of many industries. Removes varnished and cracked residues while being physiologically safe. Excellent adhesive properties enable overhead spraying
WKS-HT				- 10 > 250 (as of +300°C dry lubrication)	<p>High-temperature lubricant</p> <ul style="list-style-type: none"> Polyalkylene glycol oil, containing solid lubricants, for chain lubrication at high temperatures Excellent wetting properties and creep behavior High stability This product can be used at temperatures of up to 500°C; above 200°C there is a gradual transition to dry lubrication.
WKS-T				- 55 + 90	<p>Lubricating oil for the low-temperature range</p> <ul style="list-style-type: none"> Fast biodegradable and low-temperature multi-purpose oil based on synthetic ester with excellent wear protection The product has a low evaporation rate and is characterized by its excellent viscosity-temperature behavior and high aging resistance
WKS-Spezial Spray				- 10 + 80	<p>Chain spray for relubrication</p> <ul style="list-style-type: none"> Proven lubricant with good adhesive strength and corrosion protection for dry applications in agriculture and industry.

All lubricants supplied by WIPPERMANN are free from chlorine and silicone.

Detailed product description and safety data sheets on request.

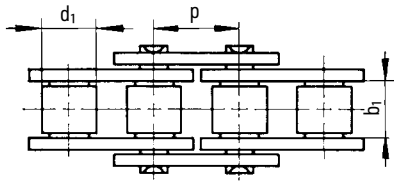

Steel link chains

Generally, steel link chains can only operate on one plane, and they are primarily used as drive elements for chain drives.

They are precisely determined by three main measurements:

- p = Pitch is the distance from pin centre to pin centre.
- b_1 = Inner width is the distance between the inner plates.
- d_1 = Roller diameter, bushing diameter or pin diameter is the outer dimension of the cylindrical parts between the inner plates.

The characteristic feature of a steel link chain is the chain joint.

It consists of an outer and an inner link. On this joint the calculated bearing area equals the projection of the pin onto the bearing area of the inner link. It has a different size depending on the type of chain.

In the following overview the characteristic features of various types of steel link chains are briefly described.

Galle chains

Galle chains were named after their inventor André Galle (1761-1841). A Galle chain is the simplest type of steel link chain.

The plates rotate directly on the pin lug. With this type of chain the bearing area is very small.

Therefore the chain speed should not exceed 0,3 m/s.

Consequently, Galle chains are less suitable for power transmission, and they are almost exclusively used as load chains (e.g. counterweight chains, lock chains and tack chains).

Galle chains on request (see page 91)

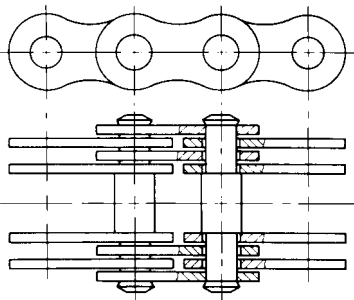

Leaf chains

Leaf chains in normal design or reinforced design are used as load chains in cranes, hoisting gear and lifting equipment as well as for counterweights, e.g. on machine tools, and also to transmit back-and-forth movements.

The plates of leaf chains are punched from high-grade steel and are subsequently hardened and tempered to guarantee high fatigue strength. Very narrow tolerances ensure that all plates bear the same load proportions. Pins made of high alloy case-hardened steel are tempered to achieve high wear resistance. The tightly adjoining plates are designed in various combinations and rotate on the pins.

One special design is the heavy-duty type series U. On chains of this type all plates are mounted with a sliding fit and are also secured with laterally attached riveted disks. This design guarantees an even load distribution and reduces the bending load of the pins. These chains were especially developed for heavy loads and operations under harsh conditions. Due to their high fatigue strength they are particularly suitable for such application areas.

Due to their design (no tooth meshing) leaf chains cannot transmit torques. Their force direction, however, can easily be deflected by means of rollers. Even with a small working width they have a high breaking load.

Dimensions as of page 82 ff.

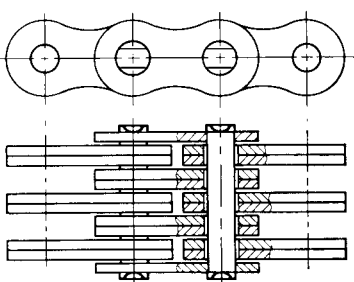

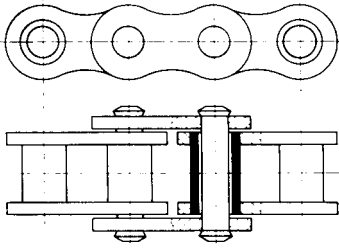

Bush chains

Bush chains are more wear-resistant than Galle chains. The inner links consist of two inner plates with two force-fitted bushings. The outer links consist of two outer plates with two force-fitted and riveted pins.

Chain speeds of up to 5 m/s are possible depending on the pitch.

Due to their robust design bush chains are mainly used as drive and conveyor chains, particularly where there are rough operating conditions, e.g. in mining or construction site equipment.

For dimensions see page 86.

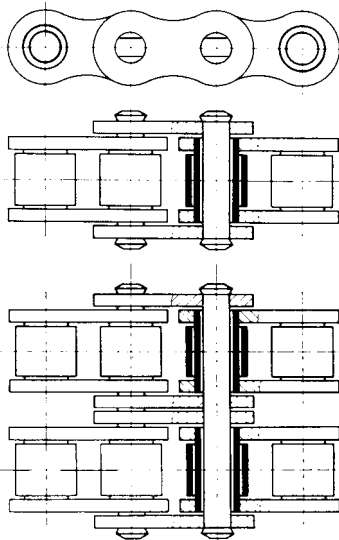

High performance roller chains

Compared to bush chains, high performance roller chains are of better quality due to the use of higher steel grades and heat treatment. Furthermore, they are produced with higher accuracy and narrower tolerances. The visible difference is the rollers, which are mounted on the bushings with running fit, and which absorb the meshing impact in the sprocket and thus reduce sprocket wear. Plates and rollers are hardened and tempered in order to achieve high fatigue strength, whereas bushings and pins, which are subject to wear, are case-hardened.

For high power transmission under restricted mounting conditions multi-strand roller chains can be used. This means that several simplex roller chains are connected by means of an end-to-end pin to form one single unit. Duplex and triplex chains are standardised.

Roller chains can be employed universally and are therefore the most common chain type. They are not only used as drive and gear chains in machine construction, but also in special designs with attachments for transport and conveyance purposes or instead of rack and pinion arrangements.

Roller chains RF made of stainless and acid-resistant steel grade 4301 have proved their value on corrosion-endangered drives and because of their anti-magnetic properties for many years. They are mainly used in the chemical, beverage and food industry.

Dimensions as of page 22 ff.

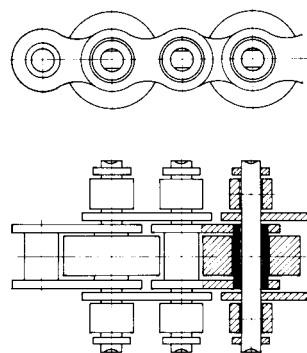

Accumulator chains

Accumulator chains are employed, when accumulation of piece goods during transportation is required. The chain runs on lateral support rollers, whereas the conveyor roller in the middle runs freely.

The particular advantages of this type of chain lie in the simple control, the exact guiding possibilities as well as in the smooth transition from one direction to another without abrupt acceleration. During intentional or unintentional accumulation of the transported piece goods no excessive impact pressure is put on the following transport units since the power and free conveyor chain will continue to run smoothly under the goods until the end of the accumulation, when transportation will continue due to friction.

For dimensions see page 6,47, 72-74.

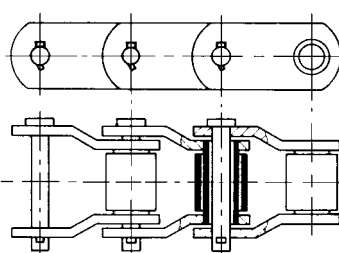

Cranked link chains (Rotary chains)

Cranked link chains (Rotary chains) are in fact roller chains, but only cranked plates are used. These plates help to give the chain a high amount of elasticity so that load impacts can easily be absorbed. It is also quite straightforward to repair cranked link chains since each individual link can be replaced.

Cranked link chains (Rotary chains) are mainly employed for applications with intermittent impacts and where the drive is exposed to rough soiling, e.g. in excavation machinery, crawlers for excavators and dozers or drilling equipment.

Cranked link chains (Rotary chains) on request 91)



- High efficiency:** η up to 0,98 with a properly lubricated chain under normal circumstances and with a drive working under full load.
- Long wear life:** \approx 15000 operating hours if the correct drive was selected and with appropriate maintenance.
- Extensive power and speed range:** P up to 225 kW with simplex roller chain $p = 76,2$ mm
Power diagram for roller chains according to ISO 606 see page 120 ff
- Long shaft distance:** The shaft distance (usually between 30 times and 50 times the pitch) has no fixed measurements. It can easily be adjusted by shortening or lengthening of the chain, even after completed assembly, in order to meet altered construction requirements.
- No slip:** In contrast to friction-locked drives chain drives have no slip. In motor vehicles, camshaft drives with chains guarantee exact valve timing.
- Multiple transmission ratios:** The transmission ratio:
$$i = \frac{n_1}{n^2} = \frac{z_2}{z^1} \text{ (usually up to approx 7:1)}$$

(in special cases up to 10:1 in one step possible) remains constant during the entire operation period due to its positive locking connection. However, it may be easily altered by simply changing the sprockets and keeping the shaft distance.
- High load capacity:** For the permissible bearing pressure with recommended lubrication please refer to the table on page 137.
- Elastic properties:** Roller chain drives have a high elasticity, because of the plate material and the lubrication layer between rollers, pins and bushings.
- Versatile applications:** Roller chains are mainly used as drive elements for power transmission or as load chains; equipped with special links they can also be used for transportation and conveyance purposes. One chain is able to simultaneously drive several shafts with the same or opposite rotational direction at the same or at different speeds. It can also be employed as a rack and pinion assembly (lantern gears).
- Cost effectiveness:** Roller chains do not need to be pre-tensioned. Therefore there are only minor bearing loads. Space-saving construction, simple mounting, low service and maintenance costs make chain drives very economical.



Designation	Symbol	Unit	Basic equations
Input speed	n	min ⁻¹	
Operating factor	k		$k = f_y \cdot f_i \cdot f_z$
Minimum tensile strength	F _B	N	see chain tables
Torque	M	Nm	$M = \frac{9550 P}{n} = \frac{F \cdot d_0}{2000}$ in Nm
Correction factor for impact loads	f _y		see page 136
Correction factor for transmission ratio	f _i		see page 137
Correction factor for shaft distance	f _a		see page 137
Correction factor for number of teeth	f _z		see page 137
Bearing area	f	cm ²	see page 22 ff.
Bearing pressure	p _r	N/cm ²	$p_r = \frac{F}{f}$ siehe Seite 135
Speed	v	m/s	$v = \frac{z \cdot p \cdot n}{60\,000}$ in m/s
Weight of chain per meter	q	kg/m	see page 22 ff
Power	P	kW	$P = \frac{F \cdot v}{1000} = \frac{M \cdot n}{9550}$ in kW
Diagram power	P _c	kW	P _c = P · k in kW
Safety factor	S		$S = \frac{F_B}{F_G}$
Impact coefficient	Y		see table page 136
PCD	d ₀	mm	$d_0 = \frac{p}{\sin \frac{180^\circ}{z}}$
Pitch	p	mm	see page 22 ff
Transmission ratio	i		$i = \frac{n_1}{n_2} = \frac{z_2}{z_1}$
Shaft distance	a	mm	
Number of teeth	z ₁ , z ₂		
Tensile force	F	N	$F = \frac{1000 P}{v} = \frac{2000 M}{d_0}$ in N
Tensile force, dynamic	F _d	N	F _d = F · f _y in N
Tensile force, centrifugal	F _F	N	F _F = q · v ² in N
Tensile force, total	F _G	N	F _G = F _d + F _F in N



Dimensioning of leaf chains

The transmissible load as well as the operating conditions i.e. type of load, chain speed, chain activity rate, impact level and operating temperature must be considered when selecting a leaf chain.

The permissible dynamic tensile force depends on the fatigue strength of plates and pins. As an indirect benchmark the breaking load of chains is used, and thus fatigue strength is taken into account by including a sufficient safety factor. Type and design of the chain determine the safety factor to be selected. In order to be able to dimension leaf chains, the tensile force F as well and the operating conditions for assessing further dynamic loads have to be known.

The tensile force F, the factor f_1 for the operating conditions and the safety factor S are crucial to calculate the required minimum breaking load F_B of the chain.

The safety factor S is subject to the regulations stipulated by various authorities and the German Technical Inspection Authority (TÜV). If there are no specific regulations, the factor S can normally be selected between 7 and 12 according to the type and design (combination of plates) of the respective chain.

Calculation of the minimum breaking load F_B

$$F_B \geq F \cdot f_1 \cdot S$$

$$F_B \geq F \cdot f_1 \cdot (n_{LW} \cdot 100 \cdot f_u)^{0,1}$$

F_B : Minimum tensile strength of chain

F : Tensile force in chain

f_1 : Operating factor

S : Safety factor

n_{LW} : No. of load cycles (fatigue limit: $n_{LW} = 10^7$)

f_u : Correction factor for PCD

$$S = (n_{LW} \cdot 100 \cdot f_u)^{0,1}$$

$$d_0 = d_u + g$$

d_0 : PCD of deflection

d_u : Diameter of contact surface of deflection roller

g : Plate height

p : Chain pitch

Load type	f_1
no impact	1,00
uniform, single slight impacts, slightly swelling load	1,25
repeated slight impacts, moderately swelling load	1,37
repeated slight impacts, highly swelling load	1,59
repeated high impacts, moderately swelling load	1,72
repeated high impacts, moderately swelling load	1,85

PCD d_0	f_u
$4,5 \cdot p$	9,10
$5,0 \cdot p$	7,14
$5,5 \cdot p$	5,95
$5,8 \cdot p$	5,43
$6,0 \cdot p$	5,13
$6,5 \cdot p$	4,52
$7,0 \cdot p$	3,79
$7,5 \cdot p$	3,70

Chain speed
up to 5 m/min.
> 5 ... 10 m/min.
> 10 ... 30 m/min.

Minimum safety factor S
7
10
12

Further details:

- For temperatures as of 100 °C higher safety factors apply. On request we will give you more detailed information as to these safety factors.
- The higher the number of plates the higher the safety factor S should be.
- For single lacing the safety factor should be higher than for double lacing.

Calculation of the bearing pressure p_r

$$p_r = \frac{F \cdot f_1}{f} \leq p_{r,zul}$$

- p_r : Bearing pressure
 f : Chain joint area
 $p_{r,zul}$: Permissible pressure in bearing area
 F : Tensile force in chain
 f_1 : Operating factor

Check and maintenance of leaf chains

Permissible wear elongation may be max. 3%. If a chain has elongated by 3% caused by wear in the joints, it must be replaced. Therefore leaf chains must be subjected to wear checks at regular intervals. These checks should comprise:

1. Check of elongation in working area (max. 3%)
2. Check of play in joints (by pushing the chain together, pulling it apart again and measuring the length difference)
3. Check of pin fit in outer plates

Deflection of leaf chains

$$d_0 = d + g$$

$$d_a = d_u + 2 \cdot k$$

$$d_R \geq d_u + 2 \cdot g$$

$$b_1 \geq l_1$$

p : Chain pitch

d_0 : PCD of deflection

d_R : Diameter with fitted chain

b_1 : Width of contact surface

g : Plate height

$$k = 0,86 \cdot \frac{g - d_2}{2}$$

$$b_2 \geq 1,2 \cdot b_1$$

d_u : Diameter of contact surface of deflection roller

d_a : Outer diameter of roller

b_2 : Roller width

l_1 : Width of chain over pin

k : Height of collar

d_2 : Pin diameter

Leaf chains heavy duty design U

$$k^* = 0,86 \cdot \frac{g - d_3}{2}$$

$$d_a^* = d_u + 2 \cdot k^*$$

d_a^* : Outer diameter of rollers (for chains with washers)

k^* : Height of collar (for chains with washers)

d_3 : Diameter of washers

Chain speed		$P_{r,zul}$	
up to 5	m/min.	14000	N/cm ²
> 5	... 10 m/min.	12000	N/cm ²
> 10	... 30 m/min.	9000	N/cm ²

In case of permanent tensile force (counter balances) $p_{r,zul}$ must be smaller than with a regularly released chain.

4. Check for fatigue failure (cracks in plates)
5. Check for deformed plates
6. Check for corrosion (pitting corrosion)
7. Check of flexibility (sufficient lubrication)

Leaf chains must be relubricated at regular intervals (see as of page 125 - 129). Sufficient lubrication will considerably reduce wear and increase the wear life by a multiple.

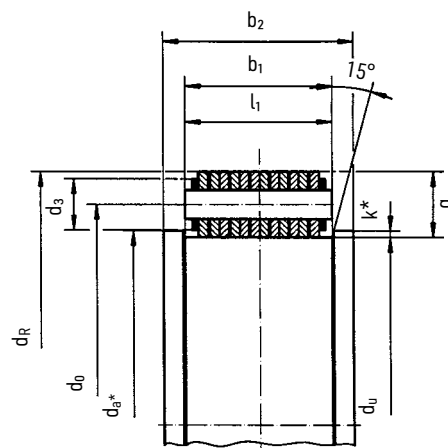
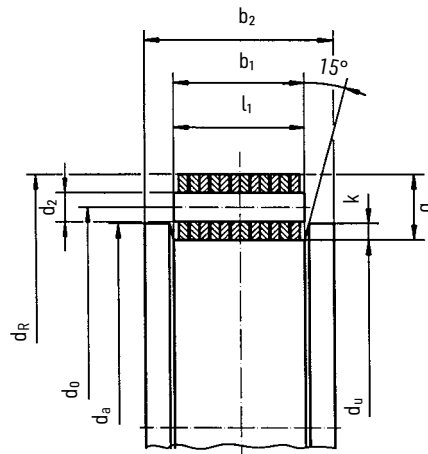



General information

The selection criteria discussed below apply to general mechanical engineering applications. Application areas such as hoisting devices (e.g. for lifting loads etc.) are excluded.

The chain life is exclusively determined by its wear behaviour. Wear occurs in the chain joints on pins and bushings. Primarily, wear depends on the chain tensile force, on deflection movements of links running along the sprockets, on the bearing area as well as on lubrication and on the number of rotations.

Therefore the chain must be dimensioned in a way that prevents overloads and fatigue failure. This means that plates and pins resist the transmissible tensile forces, rollers withstand the loads occurring when meshing with the sprocket, and that wear in the joints and on the tooth flanks remains within permissible limits.

Chain drives only have a satisfactory wear life, if the sprockets align, if they are subjected to sufficient lubrication, if there are retensioning facilities to compensate for the elongation occurring during operation, and if vibrations of the pull and return strands or torsional vibrations of the entire drive are eliminated. With new chains, the slack span in the return strand should be about 1 % of the shaft distance.

Basic information for chain selection

In order to be able to select a chain, at least the following values for power transmission must be known:

1. Transmissible power P in kW
2. Speed of driving sprocket n_1 in min⁻¹
3. Transmission ratio $i = n_1/n_2 = z_2/z_1$
4. Operating conditions of drive (application factor f_y)
5. Shaft distance a in mm

If possible, sprockets with at least 17 teeth should be selected. For chain drives with medium speeds or more, and for maximum loads we recommend sprockets with 21 tempered teeth. Normally, the maximum number of teeth should not exceed 150.

The optimal shaft distance is 30 times p - 50 times p and should allow an angle of lap of at least 120° on the smaller sprocket. On chain drives with an inclination of more than 60° clamping-jockey sprockets or automatic chain tensioners must be mounted to ensure the required chain tension.

There often is a choice between a simplex roller chain with a longer pitch and a multiplex roller chains with a shorter pitch. However, chain drives with multiplex roller chains allow smaller sprocket diameters in restricted spaces. They cause less noise and fewer vibrations than chains with a long pitch, which run on sprockets with fewer teeth.

Factor f_y to take into account specific operating conditions

Driving motor / engine	Driven equipment		
	Centrifugal pumps and compressors Printing machines Conveyors with regular infeed Paper calenders Escalators Stirring devices for liquids Rotary driers Ventilators Generators (apart from welding generators)	Piston pumps and compressors with three or more cylinders Concrete mixers Conveyors with irregular feed Screw conveyors Rolling mills direct Saws and reciprocating saws Stirring devices for solid matter Spinning and rinsing machines Brick work machines	Planing machine and pulp grinders Excavators and other building plant Roller crushers Pulling machines Welding generators Choppers Rubber processing machines Piston pumps and compressors with one or two cylinders Gas or oil drill poles Dough mixers
Electric motors in continuous operation Internal combustion engines with hydraulic coupling Water, steam or gas turbines	1,0	1,4	1,8
Electric motors, which are repeatedly started and stopped with fewer than 10 cycles/min Internal combustion engines with six or more cylinders and mechanical coupling	1,1	1,5	1,9
Electric motors, which are repeatedly started and stopped with more than 10 cycles/min Internal combustion engines with fewer than six cylinders and mechanical coupling	1,3	1,7	2,1



Table of tolerable bearing pressures with recommended type of lubrication

Chain speed in m/s	Bearing pressure p , in N/cm ² with number of teeth z on smaller sprocket														
	11	12	13	14	15	16	17	18	19	20	21	22	23	24	≥ 25
0,1	3080	3120	3170	3220	3270	3300	3320	3350	3400	3430	3450	3480	3500	3530	3550
0,2	2810	2850	2880	2930	2980	3000	3030	3060	3100	3120	3140	3170	3190	3220	3240
0,4	2700	2740	2780	2830	2870	2890	2910	2950	2980	3000	3020	3070	3100	3120	3120
0,6	2580	2620	2650	2700	2740	2760	2780	2820	2850	2870	2890	2910	2930	2960	2980
0,8	2490	2490	2560	2610	2650	2670	2680	2720	2750	2770	2790	2810	2830	2860	2880
1,0	2380	2420	2450	2490	2520	2540	2560	2590	2620	2640	2660	2680	2700	2720	2740
1,5	2290	2330	2360	2400	2430	2450	2470	2500	2530	2550	2570	2590	2610	2630	2650
2,0	2210	2240	2270	2310	2350	2370	2380	2410	2440	2460	2470	2490	2510	2530	2550
2,5	2130	2160	2190	2230	2260	2280	2290	2320	2350	2370	2380	2400	2440	2470	2500
3,0	2050	2080	2110	2140	2170	2190	2210	2240	2260	2290	2320	2350	2380	2420	2460
4,0	1740	1830	1920	2000	2070	2100	2130	2160	2180	2220	2260	2300	2340	2380	2420
5,0	1400	1550	1690	1770	1840	1910	1970	2010	2050	2100	2150	2180	2210	2240	2280
6,0	1050	1230	1410	1540	1640	1730	1810	1880	1950	1990	2040	2070	2110	2140	2180
7,0	850	1000	1150	1280	1400	1510	1620	1740	1850	1870	1900	1940	1980	2020	2060
8,0	-	800	1020	1110	1200	1310	1420	1560	1700	1740	1780	1820	1870	1910	1960
10,0	-	-	810	900	1020	1110	1200	1320	1430	1460	1500	1570	1640	1700	1770
12,0	-	-	-	-	820	910	1070	1170	1260	1300	1350	1410	1480	1540	1600
15,0	-	-	-	-	-	-	890	970	1050	1100	1150	1210	1270	1330	1400
18,0	-	-	-	-	-	-	-	-	880	960	1050	1110	1180	1240	1300

This applies to chains according to ISO 606 with pins and bushings made of case-hardened steel.

Annotation: If requested, we can supply chains made of steel grades that can be subjected to particularly high bearing pressure.

Ratio between speed n and chain pitch p for $z_1 = 25$

Pitch p	mm	8	9,525	12,7	15,875	19,05	25,4	31,75	38,1	44,45	50,8	63,5	76,2
	inch	-	3/8"	1/2"	5/8"	3/4"	1"	1 1/4"	1 1/2"	1 3/4"	2"	2 1/2"	3"
Speed n_{max}	min ⁻¹	6000	5000	3600	2700	2000	1500	1200	900	700	550	450	300

Factors to be considered in case of different operating conditions

Impact coefficients f_y (see table on page 136)

Number of teeth of driving sprocket

z	11	13	15	17	19	21	23	25	31	37
f_z	1,80	1,50	1,30	1,13	1,00	0,90	0,81	0,74	0,60	0,50

Diagram power $PC = P \cdot f_y \cdot f_z \cdot f_i = P \cdot k$

Transmission ratio

i	1 : 1	2 : 1	3 : 1	5 : 1
f_i	1,22	1,08	1,00	0,92

Shaft distance

a	10 p	20 p	40 p	80 p
f_a	1,30	1,15	1,00	0,85

Diagrams 1, 2 and 3 are typical power diagrams for chain drives with the following operating conditions:

- a) Chain drive with two sprockets on parallel, horizontal shafts
- b) Driving sprocket with 19 teeth
- c) Simplex chain without a cranked link
- d) Chain length 120 links (for shorter chains the chain life decreases proportionally)
- e) Speed reducing ratio from 1:3 up to 3:1
- f) 15000 h expected wear life; 15000 operating hours only with a maximum of 3 % elongation caused by wear
- g) Operating temperature between - 5°C and + 70°C
- h) Sprockets aligned and chain tensioned according to specifications (see page 111,145,146)
- i) Regular operation without overload, impacts or frequent restarts
- j) Clean and sufficient lubrication (see page 125-129)

Power diagram for roller chains according to ISO 606 (European type)

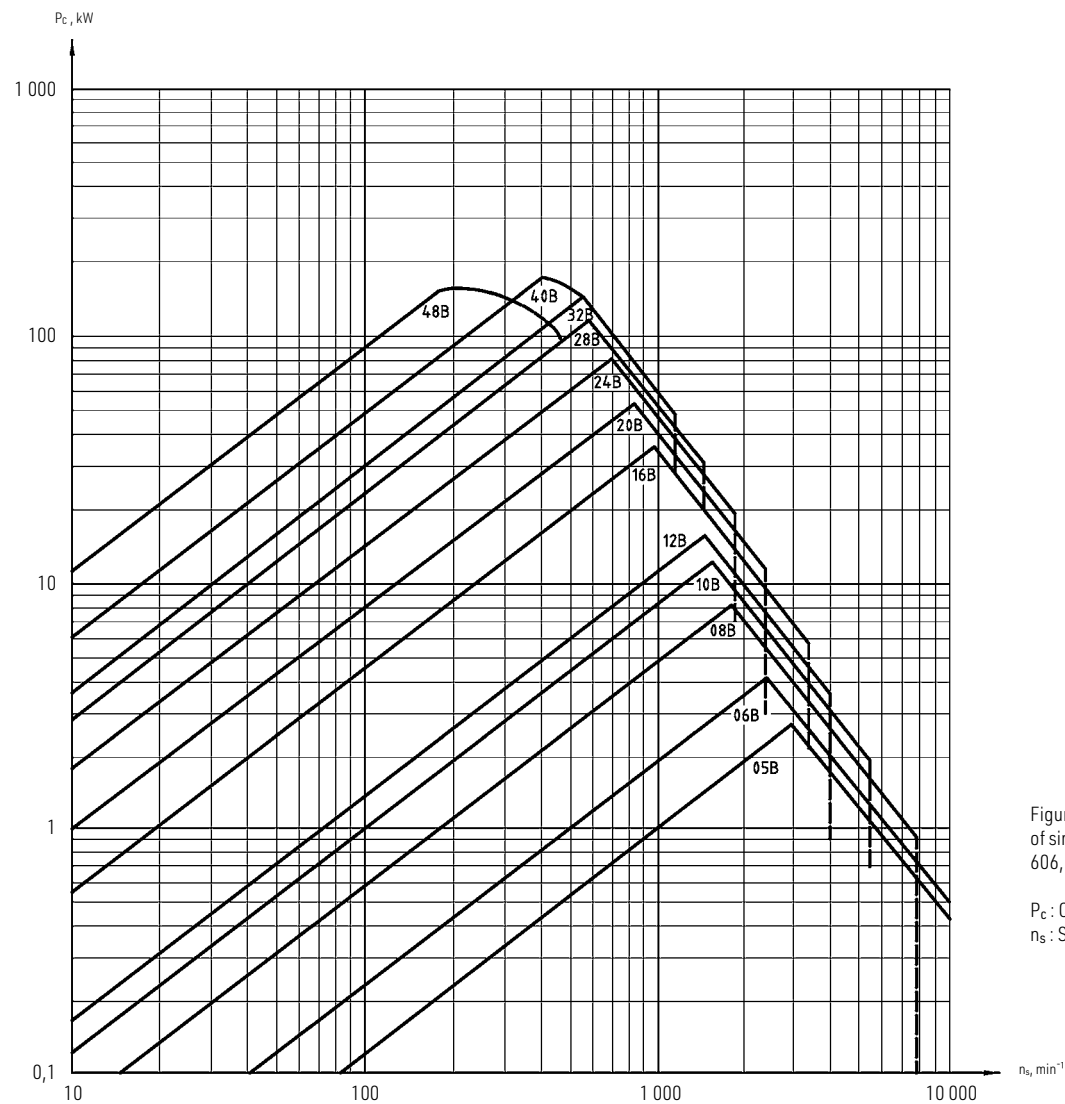

Figure 1: Typical power diagram for selection of simplex chains type B according to ISO 606, based on a sprocket with 19 teeth

P_C : Corrected power
 n_s : Speed of smaller sprocket

Annotation 1: The nominal values for the performance of duplex roller chains can be calculated by multiplying the P_C -value for simplex chains with the factor 1,7.

Annotation 2: The nominal values for the performance of triplex roller chains can be calculated by multiplying the P_C -value for simplex chains with the factor 2,5.

In case of different operating conditions, the value of the transmissible power "P" must be multiplied with the respective factor "k" in order to be able to select the appropriate chain from the diagram on the basis of the

Diagram power $P_C = P \cdot k$

The operating factor "k" takes into account the operating conditions of the drive, the number of teeth on the small sprocket, the transmission ratio and the shaft distance.

Longer wear lives can be achieved by transmitting less power than shown in the diagram.

If roller chains are operated with very low speeds or idly (e.g. as load chains), the tensile force must be calculated according to the formula $F_d = F \cdot f_y$ zu berechnen.

The safety factor should be at least $S = 7!$

Power diagram for roller chains according to ISO 606 (American type)

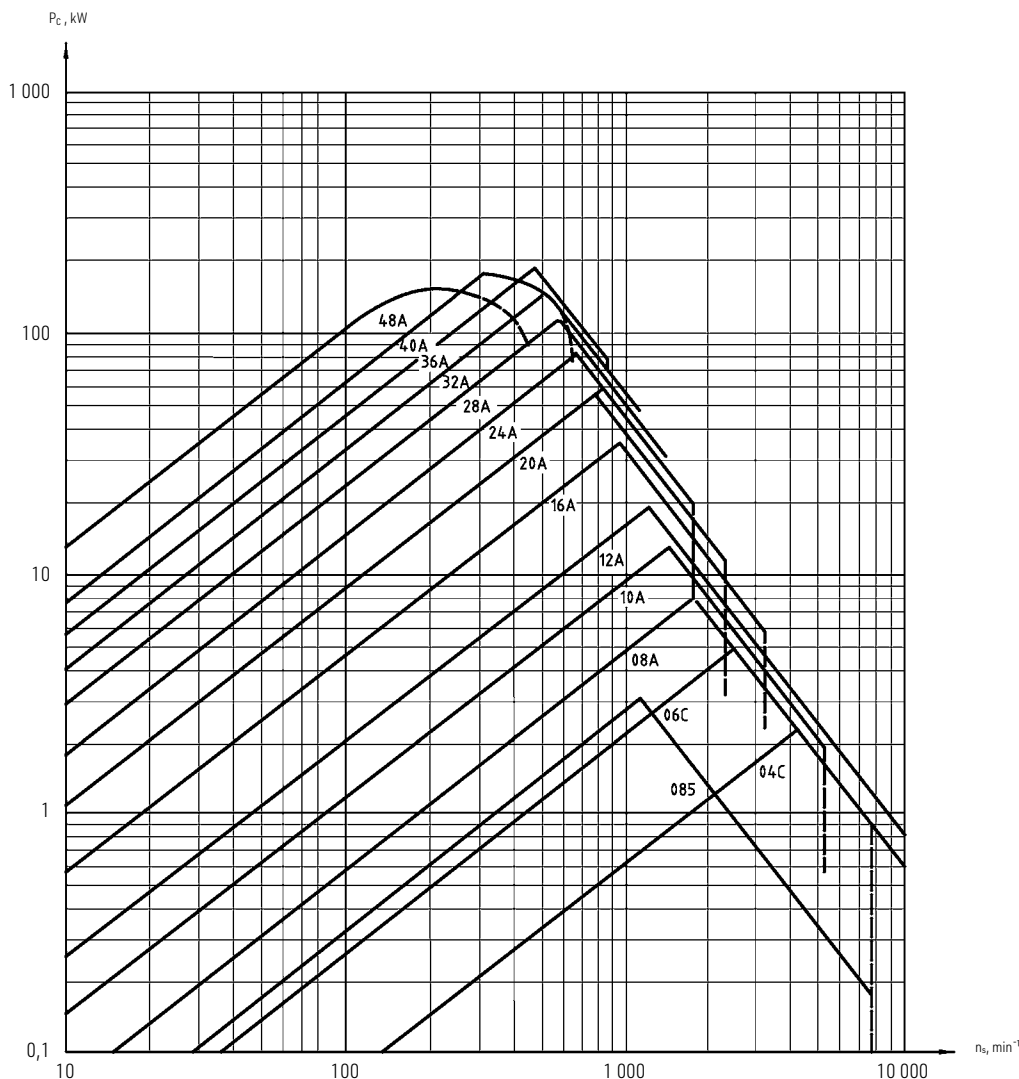

Figure 2: Typical power diagram for selection of simplex chains type A according to ISO 606, based on a sprocket with 19 teeth

P_C : Corrected power
 n_s : Speed of smaller sprocket

Annotation 1: The nominal values for the performance of duplex roller chains can be calculated by multiplying the P_C -value for simplex chains with the factor 1,7.

Annotation 2: The nominal values for the performance of triplex roller chains can be calculated by multiplying the P_C -value for simplex chains with the factor 2,5.



Power diagram for roller chains according to ISO 606 (American type, reinforced)

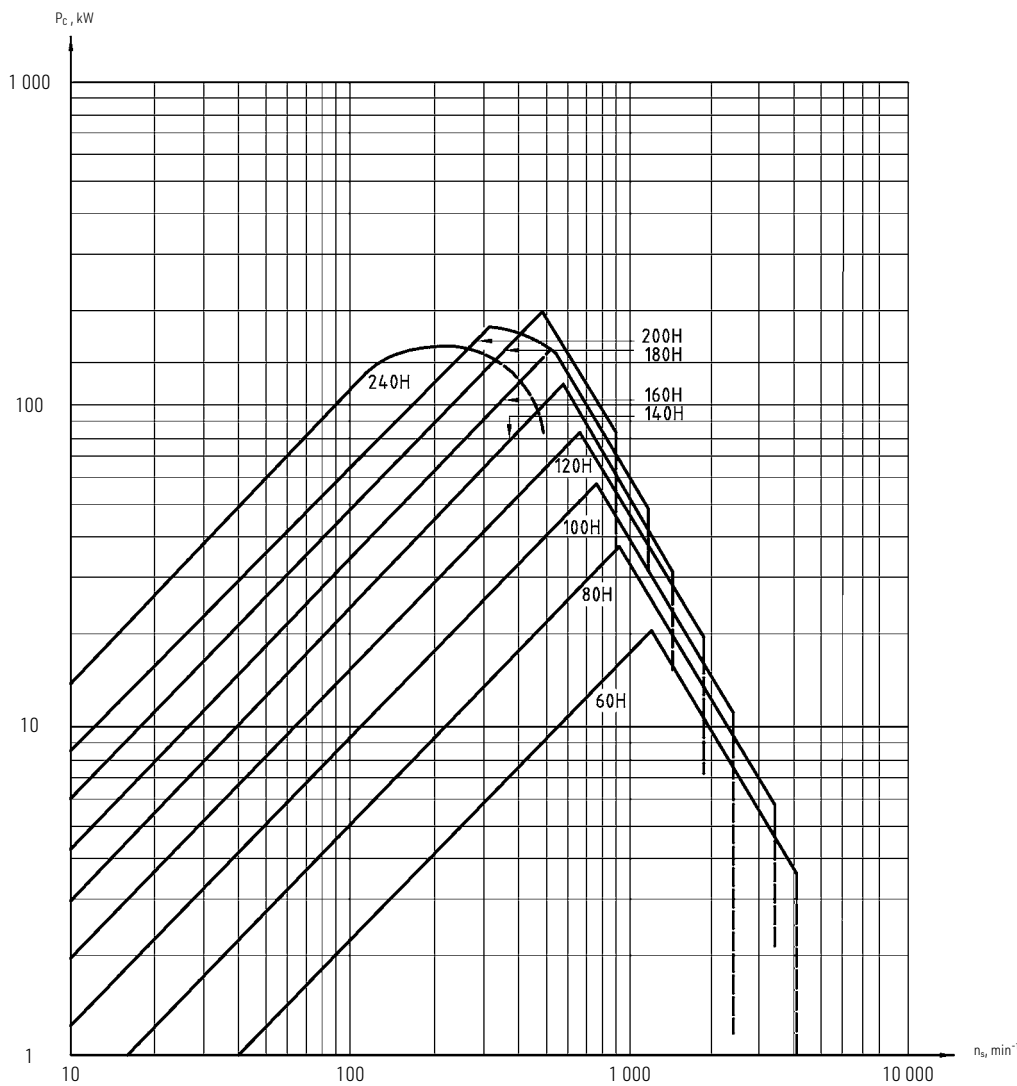
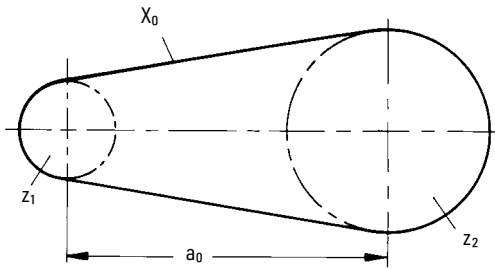

Figure 3: Typical power diagram for selection of reinforced simplex chains type A according to ISO 606, based on a sprocket with 19 teeth

P_c : Corrected power
 n_s : Speed of smaller sprocket

Annotation 1: The nominal values for the performance of duplex roller chains can be calculated by multiplying the P_c -value for simplex chains with the factor 1,7.

Annotation 2: The nominal values for the performance of triplex roller chains can be calculated by multiplying the P_c -value for simplex chains with the factor 2,5.



- X = Chain length in links
- X₀ = Theoretical chain length
- a = Shaft distance in mm
- a₀ = Theoretical shaft distance
- p = Pitch in mm
- z₁ = Number of teeth on small sprocket
- z₂ = Number of teeth on large sprocket
- C = Coefficient from table

$$C = \left[\frac{z_1 - z_2}{2 \cdot \pi} \right]^2$$

Example:

- a₀ = 700 mm
- p = 19,05 mm
- C = 17,12 (for z₂ - z₁ = 26)
- z₁ = 19
- z₂ = 45

$$X_0 = 2 \frac{a_0}{p} + \frac{z_1 + z_2}{2} + \frac{C \cdot p}{a_0}$$

$$X_0 = \frac{2 \cdot 700}{19,05} + \frac{19 + 45}{2} + \frac{17,12 \cdot 19,05}{700}$$

$$X_0 = 73,49 + 32 + 0,466 = 105,956$$

X = 106 links

With the same number of teeth z₁ = z₂ the chain length is:

$$X_0 = 2 \frac{a_0}{p} + z$$

With different numbers of teeth z₁ and z₂ the chain length is:

$$X_0 = 2 \frac{a_0}{p} + \frac{z_1 + z_2}{2} + \frac{C \cdot p}{a_0}$$

The calculated number of links must always be rounded up. In case of minor differences, one pitch should be added in order to avoid assembly difficulties. If the calculation results in an uneven number of chain links, one single cranked link (0,8 of breaking load) has to be mounted. In such cases it is recommended to select the next even number of links. Then the exact shaft distance can easily be calculated according to the detailed information on page 142.

Values for „C“= $\left[\frac{z_1 - z_2}{2 \cdot \pi} \right]^2$

z ₂ - z ₁	C	z ₂ - z ₁	C	z ₂ - z ₁	C	z ₂ - z ₁	C
1	0,025	41	42,58	81	166,19	121	370,86
2	0,101	42	44,68	82	170,32	122	377,02
3	0,228	43	46,84	83	174,50	123	383,22
4	0,405	44	49,04	84	178,73	124	389,48
5	0,633	45	51,29	85	183,01	125	395,79
6	0,912	46	53,60	86	187,34	126	402,14
7	1,240	47	55,95	87	191,73	127	408,55
8	1,620	48	58,36	88	196,16	128	415,01
9	2,050	49	60,82	89	200,64	129	421,52
10	2,530	50	63,33	90	205,18	130	428,08
11	3,070	51	65,88	91	209,76	131	434,69
12	3,650	52	68,49	92	214,40	132	441,36
13	4,280	53	71,15	93	219,08	133	448,07
14	4,960	54	73,86	94	223,82	134	454,83
15	5,700	55	76,62	95	228,61	135	461,64
16	6,480	56	79,44	96	233,44	136	468,51
17	7,320	57	82,30	97	238,33	137	475,42
18	8,210	58	85,21	98	243,27	138	482,39
19	9,140	59	88,17	99	248,26	139	489,41
20	10,130	60	91,19	100	253,30	140	496,47
21	11,170	61	94,25	101	258,39	141	503,59
22	12,260	62	97,37	102	263,54	142	510,76
23	13,400	63	100,54	103	268,73	143	517,98
24	14,590	64	103,75	104	273,97	144	525,25
25	15,830	65	107,02	105	279,27	145	532,57
26	17,120	66	110,34	106	284,61	146	539,94
27	18,470	67	113,71	107	290,01	147	547,36
28	19,860	68	117,13	108	295,45	148	554,83
29	21,800	69	120,60	109	300,95	149	562,36
30	22,800	70	124,12	110	306,50	150	569,93
31	24,340	71	127,69	111	312,09	151	577,56
32	25,940	72	131,31	112	317,74	152	585,23
33	27,580	73	134,99	113	323,44	153	592,96
34	29,280	74	138,71	114	329,19	154	600,73
35	31,030	75	142,48	115	334,99	155	608,56
36	32,830	76	146,31	116	340,84	156	616,44
37	34,680	77	150,18	117	346,75	157	624,37
38	36,580	78	154,11	118	352,70	158	632,35
39	38,530	79	158,09	119	358,70	159	640,38
40	40,530	80	162,11	120	364,76	160	648,46

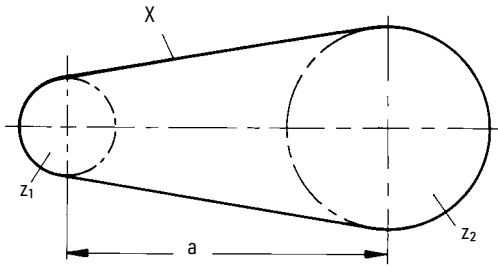

- a = Shaft distance in mm
- X = Chain length in links
- p = Pitch in mm
- z₁ = Number of teeth on small sprocket
- z₂ = Number of teeth on large sprocket

The calculation of a chain length rarely results in an even number of links. Mostly, the result must be rounded up. In order to avoid a cranked link in the chain, an even number should be selected.

The exact shaft difference is calculated according to the following formulas:

With the same number of teeth z₁ = z₂ = z the shaft distance is:

$$a = \frac{X - z}{2} p$$

With an uneven number of teeth z₁ and z₂ the shaft distance is:

$$a = p [2 X - (z_1 + z_2)] B$$

The coefficient "B" is a function of $K = \frac{X - z_1}{z_2 - z_1}$ and

can be taken from the following table.

Example:

X = 106 links z₁ = 19
 p = 19,05 mm z₂ = 45

$$a = p [2 x - (z_1 + z_2)] B$$

$$k = \frac{X - z_1}{z_2 - z_1} = \frac{106 - 19}{45 - 19} = \frac{87}{26} = 3,34615$$

The table shows a value B = 0,24825 for K = 3,2
 and a value B = 0,24849 for K = 3,4

B must be calculated by means of interpolation.
 The following applies:

$$\frac{\text{Difference K times table difference B}}{\text{Table difference K}}$$

$$B = 2,24825 + \frac{(3,34615 - 3,2) \cdot (0,24849 - 0,24825)}{3,4 - 3,2}$$

$$B = 0,24825 + \frac{0,14615 \cdot 0,00024}{0,2}$$

$$B = 0,24825 + 0,00017538 = 0,24843 \text{ (rounded up)}$$

The exact shaft distance is

$$a = 19,05 (2 \times 106 - 19 - 45) 0,24843$$

$$a = \underline{\underline{700,4 \text{ mm}}}$$

Coefficient "B"

K	B	K	B	K	B	K	B
13,0	0,24 991	2,70	0,24 735	1,54	0,23 758	1,26	0,22 520
12,0	990	2,60	708	1,52	705	1,25	443
11,0	988	2,50	678	1,50	648	1,24	361
10,0	986	2,40	643	1,48	588	1,23	275
9,0	983	2,30	602	1,46	524	1,22	185
8,0	978	2,20	552	1,44	455	1,21	090
7,0	970	2,10	493	1,42	381	1,20	0,21 990
6,0	958	2,00	421	1,40	301	1,19	884
5,0	937	1,95	380	1,39	259	1,18	771
4,8	931	1,90	333	1,38	215	1,17	652
4,6	925	1,85	281	1,37	170	1,16	526
4,4	917	1,80	222	1,36	123	1,15	390
4,2	907	1,75	156	1,35	073	1,14	245
4,0	896	1,70	081	1,34	022	1,13	090
3,8	883	1,68	048	1,33	0,22 968	1,12	0,20 923
3,6	868	1,66	013	1,32	912	1,11	744
3,4	849	1,64	0,23 977	1,31	854	1,10	549
3,2	825	1,62	938	1,30	793	1,09	336
3,0	795	1,60	897	1,29	729	1,08	104
2,9	778	1,58	854	1,28	662	1,07	0,19 848
2,8	758	1,56	807	1,27	593	1,06	564

K > 13 B = 0,25

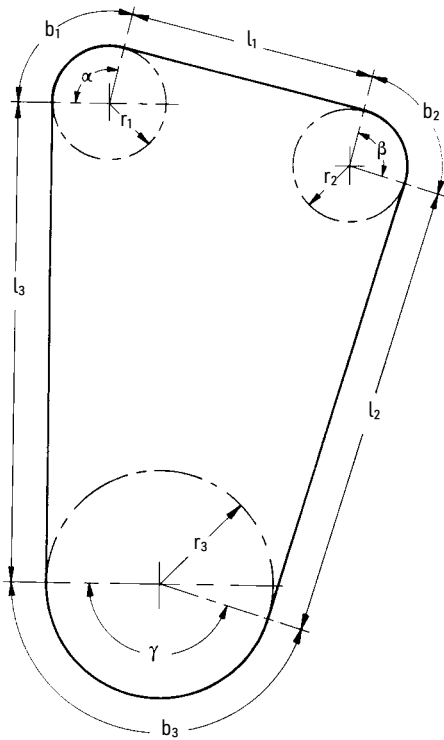

- L = Chain length in mm
- X = Chain length in links
- p = Pitch in mm
- $l_{1, 2, 3}$ = Tangent lengths in mm
- $r_{1, 2, 3}$ = Pitch circle radiuses in mm
- α, β, γ = Central angles in degrees
- $b_{1, 2, 3}$ = Arc lengths in mm
- $= r_1 \text{ arc } \alpha, r_2 \text{ arc } \beta, r_3 \text{ arc } \gamma$

Example:

(see above drawing)

Chain pitch $p = 15,875 \text{ mm}$

- $r_1 = 43,2 \text{ mm}$ $\alpha = 104^\circ$ $l_1 = 188 \text{ mm}$
- $r_2 = 43,2 \text{ mm}$ $\beta = 93^\circ$ $l_2 = 345 \text{ mm}$
- $r_3 = 86,0 \text{ mm}$ $\gamma = 163^\circ$ $l_3 = 363 \text{ mm}$

- $b_1 = r_1 \text{ arc } \alpha = 43,2 \times 1,8151 = 78,41 \text{ mm}$
- $b_2 = r_2 \text{ arc } \beta = 43,2 \times 1,6232 = 70,12 \text{ mm}$
- $b_3 = r_3 \text{ arc } \gamma = 86,0 \times 2,8449 = 244,66 \text{ mm}$

$$L = b_1 + b_2 + b_3 + l_1 + l_2 + l_3$$

$$= 78,41 + 70,12 + 244,66 + 188 + 345 + 363$$

$$= 1289,19 \text{ mm}$$

$$X = \frac{L}{p} = \frac{1,289,19}{15,875} = 81,21 = \underline{\underline{82 \text{ links}}}$$

If a chain runs on several sprockets (as shown in the drawing), graphics will usually suffice to determine the chain length since this method is sufficiently accurate and considerably simpler than mathematical calculations. To begin with, the drive is drawn schematically, if possible on a scale of 1:1 or larger. Then tangents are drawn to the pitch circles, and the central angles of the circular arc spanned by the chain are determined.

For the respective arc values please refer to the table "arc lengths".

The chain length L can then be calculated by adding up the partial lengths.

$$L = l_1 + l_2 + l_3 + \dots + b_1 + b_2 + b_3 \dots$$

$$X = L/p$$

The result must always be rounded up, if possible to the next even number of links. Uneven numbers should be avoided!

Arc lengths for the radius $r = 1$

Central angle	Arc length	Central angle	Arc length	Central angle	Arc length	Central angle	Arc length
φ°	arc φ	φ°	arc φ	φ°	arc φ	φ°	arc φ
1	0,0175	46	0,8029	91	1,5882	136	2,3736
2	0,0349	47	0,8203	92	1,6057	137	2,3911
3	0,0524	48	0,8378	93	1,6232	138	2,4086
4	0,0698	49	0,8552	94	1,6406	139	2,4260
5	0,0873	50	0,8727	95	1,6580	140	2,4435
6	0,1047	51	0,8901	96	1,6755	141	2,4609
7	0,1222	52	0,9076	97	1,6930	142	2,4784
8	0,1396	53	0,9250	98	1,7104	143	2,4958
9	0,1571	54	0,9425	99	1,7279	144	2,5133
10	0,1745	55	0,9599	100	1,7453	145	2,5307
11	0,1920	56	0,9774	101	1,7628	146	2,5482
12	0,2094	57	0,9948	102	1,7802	147	2,5656
13	0,2269	58	1,0123	103	1,7977	148	2,5831
14	0,2443	59	1,0297	104	1,8151	149	2,6005
15	0,2618	60	1,0472	105	1,8326	150	2,6180
16	0,2793	61	1,0647	106	1,8500	151	2,6354
17	0,2967	62	1,0821	107	1,8675	152	2,6529
18	0,3142	63	1,0996	108	1,8850	153	2,6704
19	0,3316	64	1,1170	109	1,9024	154	2,6878
20	0,3491	65	1,1345	110	1,9199	155	2,7053
21	0,3665	66	1,1519	111	1,9373	156	2,7227
22	0,3840	67	1,1694	112	1,9548	157	2,7402
23	0,4014	68	1,1868	113	1,9722	158	2,7576
24	0,4189	69	1,2043	114	1,9897	159	2,7751
25	0,4363	70	1,2217	115	2,0071	160	2,7925
26	0,4538	71	1,2392	116	2,0246	161	2,8100
27	0,4712	72	1,2566	117	2,0420	162	2,8274
28	0,4887	73	1,2741	118	2,0595	163	2,8449
29	0,5061	74	1,2915	119	2,0769	164	2,8623
30	0,5236	75	1,3090	120	2,0944	165	2,8798
31	0,5411	76	1,3265	121	2,1118	166	2,8972
32	0,5585	77	1,3439	122	2,1293	167	2,9147
33	0,5760	78	1,3614	123	2,1468	168	2,9322
34	0,5934	79	1,3788	124	2,1642	169	2,9496
35	0,6109	80	1,3963	125	2,1817	170	2,9671
36	0,6283	81	1,4137	126	2,1991	171	2,9845
37	0,6458	82	1,4312	127	2,2166	172	3,0020
38	0,6632	83	1,4486	128	2,2340	173	3,0194
39	0,6807	84	1,4661	129	2,2515	174	3,0369
40	0,6981	85	1,4835	130	2,2689	175	3,0543
41	0,7156	86	1,5010	131	2,2864	176	3,0718
42	0,7330	87	1,5184	132	2,3038	177	3,0892
43	0,7505	88	1,5359	133	2,3213	178	3,1067
44	0,7679	89	1,5533	134	2,3387	179	3,1241
45	0,7854	90	1,5708	135	2,3562	180	3,1416

1. Given are:

(Refer to the drawing in example 1, which illustrates this worked example)

Input power	$P = 0,16 \text{ kW}$
Input speed	$n_1 = 36 \text{ min}^{-1}$
Output speed	$n_2 = 10,75 \text{ min}^{-1}$
Transmission ratio	$i = \frac{n_1}{n_2} = 3,35$
Mode of drive	electric gear motor
Driven machine	Conveyor (with uneven charging)
Approx. shaft centre distance	$a_0 \approx 530 \text{ mm}$

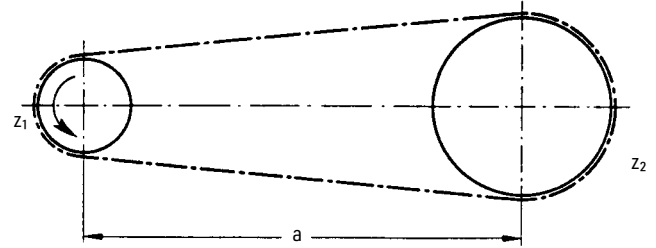
2. Selection of sprockets

Selected number of teeth on drive sprocket: $z_1 = 17$
 Number of teeth on driven sprocket: $z_2 = i \cdot z_1$; $z_2 = 3,35 \cdot 17 = 57$

3. Calculations and selection of chain
3.1 Correction of chain

Correction factor for operating conditions:
 Correction factor for number of teeth:
 Corrected power:

$$k = f_y \cdot f_i \cdot f_z \quad (f_y = 1,4; f_i = 1; f_z = 1,13)$$

$$k = 1,4 \cdot 1 \cdot 1,13$$

$$P_C = P \cdot k$$

$$P_C = 0,16 \text{ kW} \cdot 2,17$$

$$P_C = 0,35 \text{ kW}$$

3.2 Selection of chain

For $P_C = 0,35 \text{ kW}$ and $n_1 = 36 \text{ rpm}$ the roller chain 10A-1 or 10B-1 is selected from the power diagrams (see pages 138-140)
 The chain pitch p for a chain 10A-1 or 10B-1 is 15,875 mm (according to ISO 606).

3.3 Chain length

Calculation of number of links

$$X_0 = 2 \frac{a_0}{p} + \frac{z_1 + z_2}{2} + \frac{C \cdot p}{a_0}$$

Here $C = 40,529$ for $z_2 - z_1 = 57 - 17 = 40$
 Result:

$$X_0 = \frac{530}{15,875} + \frac{17 + 57}{2} + \frac{40,529 \cdot 15,875}{530}$$

$$X_0 = 104,99$$

Selected number of links $X = 106$ (i.e. the next higher even number).

3.4 Chain speed

$$v = \frac{n \cdot z \cdot p}{60\,000} = \frac{36 \cdot 17 \cdot 15,875}{60\,000} = 0,16 \text{ m/s}^2$$

4. Maximum shaft centre distance of sprockets

Maximum shaft centre distance:
 $a = p [2X - (z_1 + z_2)] B$

$$\text{Results } B = 0,24567 \text{ f\"ur } \frac{X - z_1}{z_2 - z_1} = \frac{106 - 17}{57 - 17} = 2,23 \text{ (interpolated)}$$

This is the value for the shaft centre distance:
 $a = 15,875 [2 \cdot 106 - (17 + 57)] 0,24567$
 $a = 538,2 \text{ mm}$

5. Lubrication

For $v = 0,16 \text{ m/s}$ and for a chain type 10A-1 or 10B-1 the diagram (page 126) shows the lubrication range I. Consequently, the simplest lubrication method, i.e. regular manual oil lubrication, will be sufficient in this case.

General information

Slack span of the return strand for horizontal drives approx. 1 % to 2 % of the shaft distance.

Chain contact angle on the drive sprocket 120° if possible (always the case when $a > d_0/2 - d_0/1$)

at least 90° for higher number of teeth ($z \geq 25$).

The shaft distance is normally 30 times p - 50 times p .

$$\text{minimal } a_{\min} > \frac{d_{k1} + d_{k2}}{2}$$

With longer shaft distances, heavy drives or vertical shafts, the chain weight of the pull strand and the return strand must be supported by means of chain support wheels, support rollers or guide strips. The number of teeth on the drive sprocket should be 19 if possible. The minimum number of teeth on a sprocket is 6 ($d_0 = 2p$), which is then only suitable for manual operation because of the polygon effect!

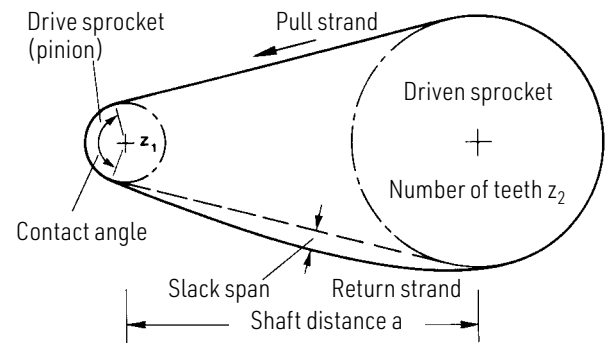

Chain drive configurations (assessment)

Favourable

In order to guarantee trouble-free operation and a long wear life, the correct chain run for the different drive configurations has to be selected. A horizontal drive or a configuration with a drive inclined by up to 60° is common and favourable. In this case the pull strand should be at the top and the return strand at the bottom.

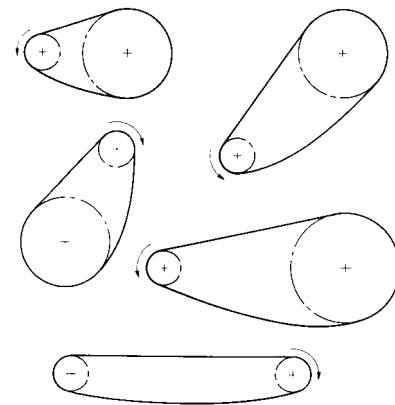

Less favourable

With horizontal drives and normal shaft distances the return strand may also be at the top.

Vertical drives should have the smaller sprocket at the top. The chain must be kept rather tight to stop it from getting slack and jumping off the lower sprocket. A minor deviation from the vertical position will improve the running conditions. It might be necessary to mount a jockey sprocket.

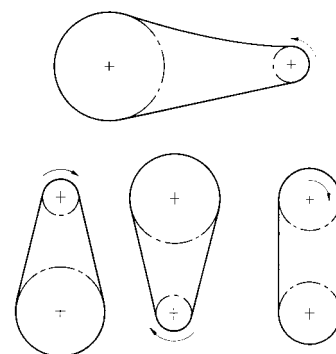

Please avoid if possible

In case of short or long shaft distances the pull strand should be at the top if possible!

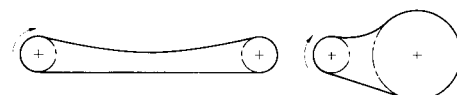



Jockey sprockets should have approximately three teeth in mesh with the return strand of the chain. On the basis of the selected number of teeth, the maximum speed (see page 137 "ratio between n and p") must not be exceeded.

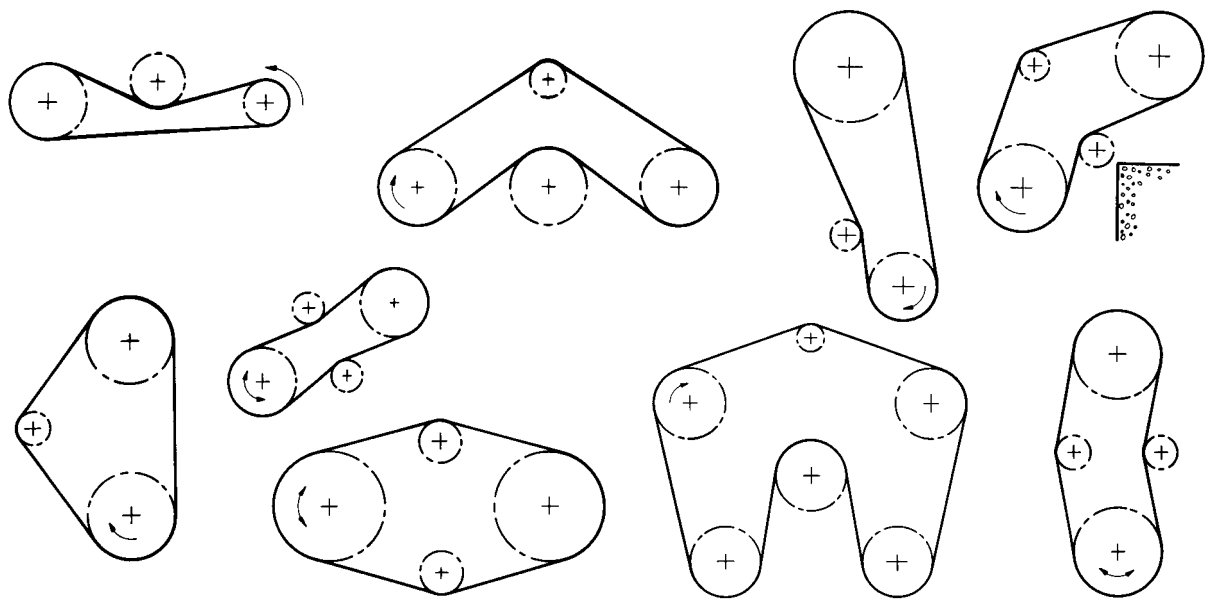

Instead of jockey sprockets, support wheels or deflexion pulleys, plastic guide rails might be advantageous in some cases to support or deflect a chain.

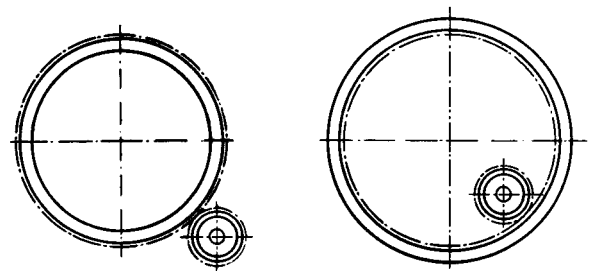

Roller chain instead of a sprocket for large wheel bodies, drums, revolving platforms etc.

Driving of roller conveyors

- a) by means of alternate individual chain strands driving from roller to roller
- b) by means of a circulating chain with lantern gear toothing sprockets (p.102)

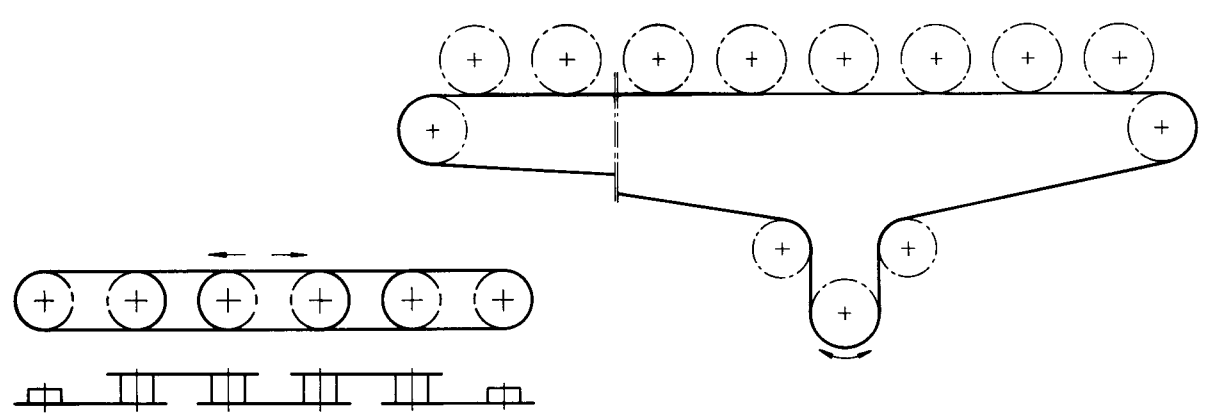



Questionnaire for chain drives

What is to be conveyed or driven by the chain? (If an existing chain drive is to be replaced, please state which one!)

.....

.....

Chain drive

Please underline where applicable and enter the respective data if necessary!

Power requirement (max. power to be transmitted) power output $P =$ PS/kW torque $M =$ Nm tensile force $F =$ N

Drive (type and performance) / PS/kW
(e.g. electric motor, internal combustion engine / 2, 4, 6 cylinders etc.)

Chain loading operation period hours/day
 regular cyclic impact alternating direction times per hour
 interruption (re-start) approx. times per hour

Centrifugal mass for impact compensation existing possible not existing not possible

Axial distance $a =$ mm
 shaft distance is adjustable by mm / not adjustable
 jockey sprocket clamping rail clamping spring automatic chain tensioner

Ambient influences nothing in particular dust fibres sand humidity
 temperatures up to °C corrosion caused by

Chain protection box dust proof not dust proof installation not possible
 chain unprotected chain protected by engine / machine housing

Lubrication not permitted manually (occasionally) drip feed oil bath pressure circulation

Sprockets

	Driving sprocket	Driven sprocket
Speed	$n_1 =$ rpm	$n_2 =$ rpm
or		
planned transmission ratio	$i =$	

Sprocket diameter (Ø) Largest possible incl. chain	max. = mm	max. = mm
--	-----------------	-----------------

Sprocket width Largest possible incl. chain	max. = mm	max. = mm
---	-----------------	-----------------

Sprocket design
Hub bore (shaft Ø)	$d_1 =$ mm	$d_2 =$ mm

Hub length	$L_1 =$ mm	$L_2 =$ mm
-------------------	------------------	------------------

Hub design One-sided: standard Double-sided: symmetrical or asymmetrical
---	-------	-------

Installation on the shaft (groove sizes according to DIN)
---	-------	-------

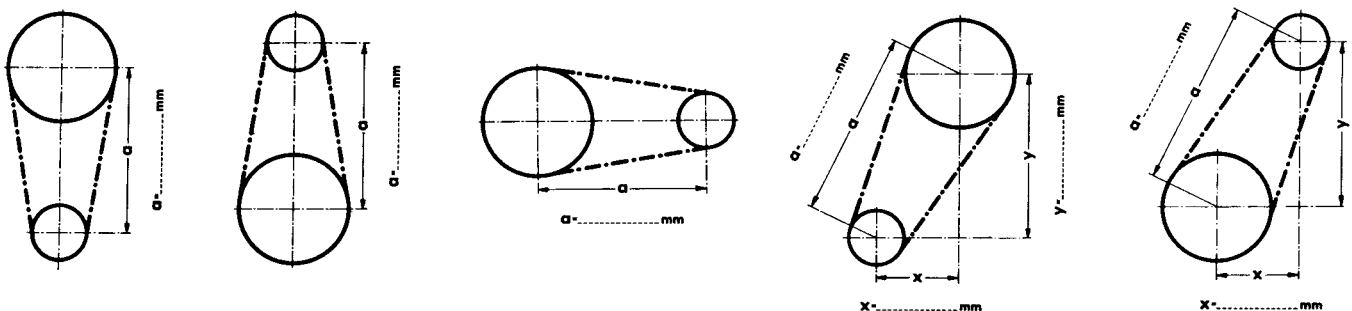

Please enter the dimensions of the requested drive into the drawing. The driving wheel designation should be T. Please indicate the rotation direction by an arrow and in case of alternating rotation direction by a double arrow (↔).

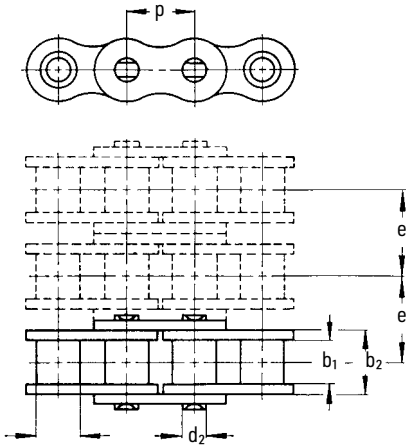

In order to avoid errors or misunderstandings please supply the following details:

Number of chains

⚙️ -Chain No.

If this is unknown e.g. when ordering replacement chains, please supply a short part of the chain as a sample (at least one inner link) or, alternatively, state the following dimensions according to the adjoining drawing:

1. Pitch p
2. Inner width b_1
3. Inner link width b_2
4. Roller and bushing diameter as well as
5. Pin diameter for Galle chains d_1
6. Shoulder diameter for Galle chains d_2
7. Transverse pitch (only for multiplex roller chains)
8. Please state, if simplex, duplex or multiplex chain designs are required

For replacement chains it is sufficient to state the main dimensions p , b_1 and d_1 as well as e for multiplex chains. If a chain is to be extended or repaired, all the dimensions shown in the drawing must be supplied.

Please note: In case of replacements it is important to replace both sprockets as well as chains!

Length of chain in meters or links

- a) When ordered by length in metres (e.g. 5 m) the end links are always inner links. Connecting links must be ordered separately.
- b) When ordered by number of links:

Orders for chains with even number of links

	chain is supplied:
ready to be installed	including one connecting link
open*	end links = inner links including one single cranked link
endless	riveted

Orders for chains with odd number of links

	chain is supplied:
ready to be installed*	(up to a pitch of $p = 19,05 \text{ mm} = 3/4''$) including one double cranked link and one connecting link (up to a pitch of $p = 25,4 \text{ mm} = 1''$) including one single cranked link
open	end links = inner links
endless*	riveted (including one cranked link)

* When cranked links are used, roller chains may only have 80 % of the breaking load. Avoid if possible!

What will the chain be used for?

Please inform us on the application area of the chain. Only then will we be able to offer you the perfect chain for the application you have in mind – and you will benefit from our long-time experience!

Parallel running chains

Chains envisaged for parallel running operation are matched for length, pre-stretched and marked at extra cost.

It is important to clearly stipulate this requirement when ordering!

In special cases measured chains can be supplied at extra cost.

In order to avoid errors or misunderstandings please supply the following details:

Number of chains

-Chain No. of the basic chain

Type of attachment links

(e.g. A, B, C, D, E or F); for other special designs please state if single-sided or double sided attachments are required.

Attachment spacing T of special links

in (preferably even) multiples of pitch p

If attachments are also available on the inner link, the attachment spacing can be arranged in any way. In case of an odd number (e.g. $T = 3p$) the attachment is alternated on the outer and inner rings. If inner link attachments are not available, an odd number spacing can only be made possible by mounting a cranked connecting link No. 12 or a double cranked link No. 15. In this case the chain may only have 80 % of the breaking load!

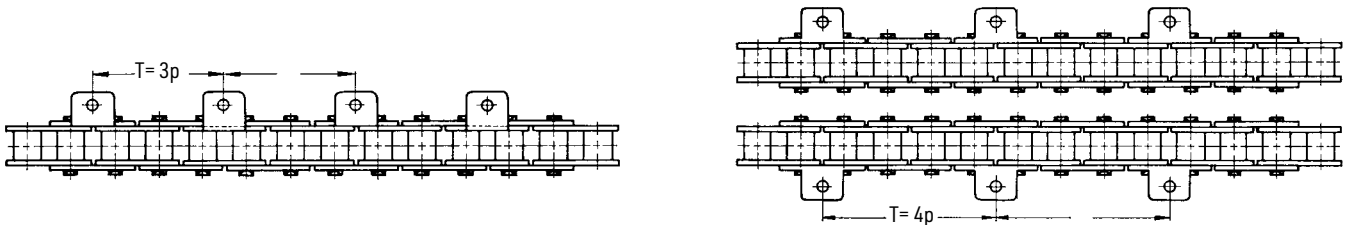

Length of chain in metres and links

- When ordered by length in metres, the end links are always inner links. Connecting links must be ordered separately!
- When ordered by a certain number of links, this number should be divisible by the distance T of the special links (e.g. chain length 176 links, $T = 4p$, i.e. every 4th link is a special link; the chain includes $176 : 4 = 44$ special links).

If the chain length cannot be a multiple of T , but has to be longer or shorter for design reasons, this fact must be clearly stated as: "Does not work out even!"

In such a case the distance T at the end of the chain will be alternately longer or shorter.

Chains with an even number of links will be delivered with a connecting link and are ready for assembly. With a distance of $T = 2p$ (each outer link is a special link) the connecting link is supplied in the respective special design. With a distance of $T = 4p$ and more the connecting link will be supplied in the standard design.

Please note: When cranked links are used, roller chains may only have 80% of the breaking load. Avoid if possible!

Matched or pre-stretched special chains

Parallel running chain strands used for transport and conveying purposes are often required to have highly matching opposite attachments. At extra cost we will supply the appropriately matched chain strands and mark them accordingly.

When ordering your chain, please state clearly: Please supply matched, pre-stretched and marked chain strands!

The installation of guide rails is recommended to help support and guide chains with long span lengths.



General information

A chain drive needs relatively little maintenance, if the correct chain was selected, if it was installed correctly and if it is lubricated according to the recommended procedure.

However, the chain should be protected against dirt and adverse environmental influences. A chain protection box helps to prevent dirt, averts accidents and absorbs noise.

In case of protected drives maintenance comprises a regular (annual) cleaning of the oil container and a renewal of the oil filling.

Open running chain drives must be cleaned every 3 to 6 months.

Shorter periods may be necessary, if the chains are very dirty. When cleaning the chain drives, wheel alignment and chain tension should be checked as well.

Cleaning

First of all, in order to clean a chain drive properly, the external rough dirt must be removed by means of a hard or steel brush. Subsequently, the chain is rinsed in cleaning solvent, paraffin or diesel oil.

Furthermore, it is important to clean the inner parts of the chain. Therefore the chain is placed into paraffin, diesel oil or another solvent for approximately 24 hours in order to soak the dirt in the joints as well as the hardened lubrication remnants.

If the chain is moved several times back and forth in the solvent bath, joints will be thoroughly cleaned.

After the chain has been properly cleaned it should not make anymore scratching noises when the links are moved; if it does, the remaining dirt in the joints will form a grinding compound with the lubricating agent, which would destroy the chain very quickly.

Repair

Subsequently the chain should be carefully examined for defective links, which must be replaced, if necessary.

A damaged outer link is replaced with a connecting link. Outer links are riveted into endless chains.

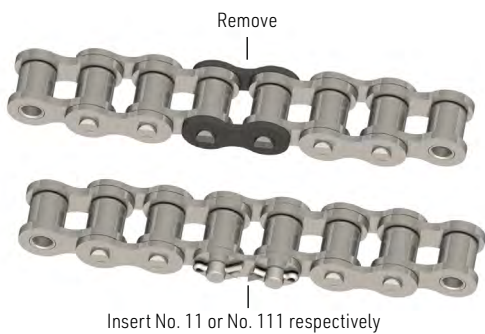

If an inner link or a roller is broken, the two adjoining links must also be removed; they must then be replaced by an inner link with two connecting links.

With endless chains outer links are to be used. However, if a chain looks really worn, it should be replaced by a new one.

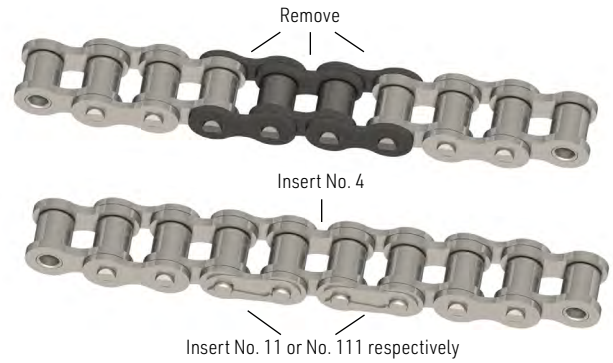

Relubrication

Thorough relubrication is to be carried out immediately after cleaning and, if necessary, repair of the chain. It is important to ensure that quality and viscosity of the lubricant comply with the operating conditions of the chain drive, e.g. temperature and velocity (please refer to pages 105 ff. It is not recommended to add just a few drops from the oil can or simply douse the chain, since the oil will not reach the chain links, i.e. those parts which actually have to be lubricated. Even if the inner and outer plates are oiled, this will by no means guarantee a proper lubrication of the inner parts such as pins and bushings.

For perfect lubrication the chain is placed into a container with liquidised special chain lubricant heated up to 120° C. The chain is left in the lubricant bath until it has reached its temper-ature, before it is then taken out. Excess lubricant must be allowed to drip off since it will not aid the lubrication of the chains links if it sticks to the outer plates.

However, in practice, such perfect lubrication will rarely be possible. In this case an excellent engine lubricating oil should be used according to the recommendations on page 126 Please ensure that the lubricant will actually reach the links, which are to be lubricated.

Sprockets

The sprocket teeth must be thoroughly cleaned before the chain is finally put back on. It is particularly important to remove dirt sediments, which would stretch the chain, from the bottom of the tooth gaps.



Subsequently, the sprocket must be examined in order to determine, if the teeth are worn too much. In case of excessive wear or hooked-shaped teeth, sprockets should be replaced with new ones.

It is not recommended to simply turn a worn sprocket around so that it works in reverse running direction. New sprockets are to be checked according to the specifications on page 109.

Please note that a new chain should never be placed around a worn sprocket, because this will definitely reduce the lifecycle of the chain.

Shortening by 1 link

a) Even number of links

up to a pitch of 19,05 mm

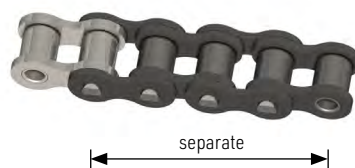

Pitch as of 25,4 mm



b) Odd number of links

up to a pitch of 19,05 mm



Pitch as of 25,4 mm



Extending by 1 link

a) Even number of links

up to a pitch of 19,05 mm



Pitch as of 25,4 mm



b) Odd number of links

up to a pitch of 19,05 mm



Pitch as of 25,4 mm



Please note: When cranked links are used, roller chains may only have 80 % of the tensile strength.

Chain breakers

Chain breaking without a breaker tool

The chain breaker ensures a fast and simple breaking of the chain for shortening or for replacing a defective part. WIPPERMANN offers suitable chain breakers for different roller chain types according to ISO 606 up to a pitch of 1".

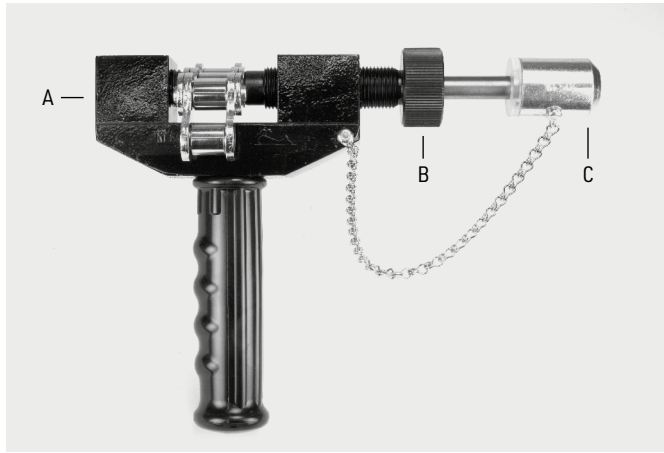

No.	suitable for the following chains
KT 455	454, 455, 331, 332, D 455 / ASA 35, 40, 41, 35-2, 40-2
KT 462	331, 332, 17, 18, 385, 460, 461, 462, D 462 / ASA 35, 40, 41, 40-2
KT 501-513	500, 501, 513, D 501, D 513 / ASA 50, 60, 50-2
KT 548	548 / ASA 80



No.	suitable for the following chains
CT 25	$\frac{3}{8}$ " bis $\frac{5}{8}$ "
CT 60	$\frac{3}{4}$ " bis 1"

Accessories: Screw A, Screw B, Replacement pin C

Chain pullers

Easy mounting of connecting links

Due to the overall weight it is often extremely cumbersome to assemble two chain ends without any tools. By means of our practical chain puller, the two ends of the chain are pulled together far enough for a connecting link to be mounted without any difficulties.

This chain puller can be supplied in two sizes:



No.	For chain pitches p	Clamping width	Weight
135	12,7 bis 19,05 mm	50,0 mm	0,2 kg



No.	For chain pitches p	Clamping width	Weight
180	25,4 bis 63,50 mm	125,0 mm	1,0 kg



Conditions/Symptoms	Possible cause	What to do
One-sided wear on chains and sprockets	1. Shafts not parallel, sprocket and pinion not aligned	1. Realign
Wear on inner plates or on sides of sprocket teeth	1. Sprocket and pinion not aligned or shaft wobble	1. Realign sprockets
Wear on tooth heads	1. Chain elongation 2. Tooth error	1. Replace chain 2. Replace pinion and sprocket
Wear on tooth flanks, sprockets	1. Low material strength	1. Exchange for hardened sprockets
Wear on outer plates	1. Chain striking an obstruction	1. Make sure chain is not obstructed
Chain vibrates with high frequency	1. Eccentricity or sprocket wobble 2. Broken chain roller	1. Replace sprockets 2. Replace chain links or chain
Premature elongation	1. Insufficient lubrication or wrong chain size	1. Increase oil supply and check chain size
Rust-coloured discolouration of chain and pins	1. Insufficient lubrication	1. Improve lubrication
Chain jumps off sprocket	1. Excess chain slack 2. Chain riding too high on sprocket teeth due to chain wear	1. Adjust shaft centre distance or jockey sprocket 2. Replace chain
Broken chain parts	1. Drive overloaded 2. Excess chain slack and chain jumps off sprocket 3. Chain striking solid object 4. Chain speed too high 5. Imprecise tothing on the sprockets 6. Insufficient lubrication 7. Corrosion	1. Select another chain or avoid overload 2. Regular check and adjustment of shaft centre distance 3. Make sure chain is not obstructed 4. Check chain dimensioning 5. Change sprockets 6. Improve and increase lubrication 7. Avoid corrosion or use chains made of stainless material (please enquire)
Excessive noise	1. Chain striking an obstruction 2. Insufficient lubrication 3. Missing or broken rollers 4. Misalignment 5. Chain jumps off sprocket	1. Make sure chain is not obstructed 2. Improve lubrication 3. Replace chain or defective parts 4. Align shafts and sprockets 5. Re-adjust shaft centre distance

A

Accumulator chains - MARATHON	46,47
Accumulator chains	72-74
Acid-resistant chains RF (stainless steel)	48-53, 60-61,64-73
Advantages of roller chain drives	132
AFS-Clip	75
Agricultural chains according to DIN 8189	58
Alignment of the sprockets	111
ASA roller chains, ISO 606	25-27,43,53,59
ATC chains	76-79
Attachment chains	62-71
Automatic chain tensioners	118-122

B

Bearing area	22 ff.
Bent attachments	62,64-68
BIATHLON	30,31
BIATHLON KS	32-35
Breaking load	22 ff.
Bush chains	
Construction and applications	131
Conveyor chains with bushings	91
Dimensions according to DIN 8164	86

C

C-Profile	122,123
Calculation of chain drives	144
Calculation of chain length L (in metres)	144
Calculation of chain lengths	141-144
Calculation of chain length X (in links)	141
Calculation of shaft distance a	142
Calculation of sprocket diameters	109
Calculation of sprockets	109
Centre to centre distance A for sprockets	108
Chain breaker	152
Chain cleaning	150
Chain couplings	106
Chain disassembly	151
Chain drive configurations with jockey sprockets	146
Chain drives	
Calculation (examples)	144
Configurations	141-144
Chain lengths	
Calculation	141
Chain lubricant	125-129
Chain maintenance	150
Chain parts	22 ff.
Chain puller	152
Chain repair	150,151
Chain selection (example)	144
Chain separation	151
Chain tensioning	145
Combination attachment chains	71
Connecting link No. 11, 111	22 ff.
Connecting links	22 ff.
Connecting link with cottered pin No. 111 or 12	22 ff.
Construction	130,131
Construction of chain drives	145,146
Construction of steel link chains	130,131
Contact angle	145
Conveyor chains	91
Cranked link chains, roller chains with cranked links	91

D

Determination of chain length L (graphically)	143
Diagram power PC	138-140
Diameters of sprockets	109
Details for	
Construction of chain drives	145,146
Enquiries and orders	148,149
Different types of steel link chains	130,131
Dimensions of chains	22 ff.
Dimensions of standard sprockets	92ff

Double cranked link No. 15	22 ff.
Duplex roller chains	23,26,31,34,37,39,42-44,48,49,51,55,59
Double pitch roller chains according to DIN 8181 and stainless steel	60
MARATHON double pitch roller chains	45
with bent attachments	68
with single hole straight attachments and extended pins	69
Drip lubrication	127
Drum drives	146
Dry running	126

E

End links	
for leaf chains	85
Enquiries about sprockets, details	110
Efficiency	126
ETP shaft bushing	116,117
Extended pins	63,65,69,70
Extending of chains	151

F

Factor for the number of teeth n	
Calculation	109
Table	112
Factors for chain calculation	133-137
Factors for impact coefficient fy	136
Faulty mounting of chain drives	111
Favourable lubrication	126
Formulas, designations and units	133

G

Galle chains	
According to DIN 8151	91
Construction and applications	130
Groove sizes	107

H

Hardening of sprockets	107
Hollow pin chains	61
Hub dimensions (standard sprockets)	92 ff.

I

Induction hardening of sprockets	107
Inner link No. 4	22 ff.
Inner width b1	22 ff.
Inside thread	66,67
Inverted tooth (silent) chains	88
Inverted tooth (silent) chains type series HD	89
Inverted tooth (silent) chains type series HP	90
Inverted tooth chains with bushings	87

K

Keyways, sizes	107
----------------------	-----

L

Lantern gear toothing	102
Leaf chains	
Construction and applications	130
Dimensions	82-84
Link numbers	141
Lubrication	125-129

M

Main chain dimensions	130,131
Maintenance-free chains overview	29
Maintenance-free chains MARATHON, stainless steel	48,49
Maintenance-free chains MARATHON	40-47
Maintenance-free chains TRIATHLON HT	36,37
Maintenance-free chains TRIATHLON KS	38,39
Maintenance	150
Maintenance of chain drives	150
Manual lubrication	126,127
MARATHON Lift, wartungsfrei	16-21
MARATHON, maintenance-free, stainless steel	48,49

MARATHON, maintenance-free	40-49
Matched chains	148, 149
Mounting of chain drives	111
Multiplex roller chains	
Dimensions according to ISO 606 European type and American type	23, 24, 26, 27, 28, 31, 34, 35, 37, 39, 42-44, 47, 49, 51, 52, 55, 59, 71, 73
N	
Nominal power P	138-140
Number of teeth	92 ff.
O	
Oil bath	127
Oils	125-129
Operating factors k	133
Orders, details	148
Orders of special chains, details	149
Outer diameter of sprockets	109
Outer link No. 7 (to be riveted)	22 ff.
P	
PCD	
Calculation	109
for roller chain sprockets	113-115
Pitch angle	109
Pitch p	22 ff.
Plastic rollers	46, 47, 61, 72, 73
Plate end links	
for leaf chains	85
POM-Clips	54, 55
POM-Clips POM clips with top surface TPU	56, 57
Power chains	59
Power diagrams	138-140
Pre-selection of leaf chains	134, 135
Pre-selection of roller chain drives	136 ff.
Pre-stretched chains	148, 149
Pressure circulation lubrication	126, 127
Profile of sprockets	109
Pull strand	145
Pusher dog	80
R	
Recommended lubrication and lubricants	125-129
Replacing of chain links	150, 151
Required space for standard sprockets	92 ff.
Return strand	145
Rigid chain systems MARATHON Lift	16-21
Roller chains	
Construction	130, 131
Dimensions according to ISO 606 and factory standards	22 ff.
Heavy duty design	59
Power chains	59
Type series GL	28, 31, 33, 37, 39, 44, 49-52, 54-57
with bent attachments	62, 64-68
with extended pins	63, 65, 69, 70
with single hole straight attachments	63-67, 69
Roller conveyors with chains	146
Roller diameter d1	22 ff.
Root circle diameter, calculation and checking	109
S	
Safety factors for leaf chains	134, 135
Shaft bushings	116, 117
Shaft centre distance, shaft distance	142
Shaft distance	
Calculation	142
Guidelines	145, 146, 150
Shortening and extending of roller chains	151
Side bow chains	53
Simplex roller chains	
Construction and applications	130, 131
Dimensions according to ISO 606 and factory standard specifications	22, 25, 28, 30, 32, 36, 38, 40, 44, 46, 48, 49, 50, 53, 58, 59, 62 ff.
Type series RF made of stainless and acid-resistant steel	48-53, 60, 64-73
Single cranked link No. 12	22 ff.
Slack span	145
Slide rails made of polyethylene material	122-124
SPANN-BOX®	118-121
SPANN-BOY®	118-121
Special heavy duty chains	59
Speed range of roller chains	137-140
Speeds	
Bush chains	86
for roller chains refer to "Speeds and chain pitches"	137
also refer to "Lubrication"	126
Speeds and chain pitches	137
Splash lubrication (oil bath method)	127
Spray	128
Spring clip connecting link (connecting link No. 11)	22 ff.
Sprocket designs	107
Sprocket diameters (table)	
for roller chains	113-115
Sprockets	
Axial profiles	108
Calculation	109
Design "A" (plate sprockets)	103-105
Design "B" (with hub on one side)	92-102
Designs and steel grades	107
Tooth design	109
Sprockets made to specifications	101, 102
Stainless steel chains	49-52, 60, 64, 65, 68, 69, 72-74
Stainless steel chains RF	48-53, 60, 64-73
Standard sprockets	92 ff.
Steel C-profile	122, 123
Straight attachments	63-69
T	
Tables for chain dimensions	22 ff.
Tip circle diameter	
Calculation	109
Table	113-115
To be riveted, outer link No. 7	22 ff.
Tooth designs	109
Toothings, hardened	107
Toothings	109
Toothings check	109
Top-plate conveyor chains	81
Transverse pitch e 23, 24, 26-28, 31, 34-35, 37, 39, 42-44, 46-47, 49, 51-52, 59, 71-73	24, 27, 31, 35, 37, 39, 42-44, 49, 52, 59
Triplex roller chains	24, 27, 31, 35, 37, 39, 42-44, 49, 52, 59
V	
Validity of power diagrams	138-140
W	
Wear life	136, 138-140



1	WIPPERMANN jr. GmbH Direkt	Service-Stützpunkt Albert-Einstein-Straße 1 32278 Kirchlengern	Phone: +49 5223763330 Fax: +49 5223763338 E-mail: direkt@wippermann.com
2	Donald Mertner	Industriervertretungen Johannesweg 17 b 33397 Rietberg	Phone: +49 52449069809 Fax: +49 52449069810 Mobile: +49 1716203193 E-mail: donald.mertner@freenet.de
3	Regionalvertretung West	Lars Böhrer Kolpingweg 6 59505 Bad Sassendorf	Phone: +49 29459660842 Fax: +49 29459660845 E-mail: lars.boehmer@wippermann.com
4	Regionalvertretung Bayern	Christoph Hein Gewerbering 4 85258 Weichs	Phone: +49 81362289315 Fax: +49 81362289316 Mobile: +49 1622653814 E-mail: christoph.hein@wippermann.com
5	Regionalvertretung Baden-Württemberg	Thomas Roth Im Herdle 7 88630 Pfullendorf-Mottschiefß	Phone: +49 75522209871 Mobile: +49 1732593115 E-mail: thomas.roth@wippermann.com



Austria	KATENA Stahlgelenkketten Handelsges. m.b.H Jedlersdorfer Platz 7 1210 Wien	Phone: +43 12921071 Fax: +43 12929762 E-mail: office@katena.at Internet: www.katena.at
Bosnia / Herzegovina	BELL d.o.o. Ptujška Cesta 13 2204 Miklavž na Dravskem polju Slovenia	Phone: +386 26296920 Fax: +386 26292120 E-mail: info@bell.si Internet: www.bell.si
Brazil	R.T. Comercial Ltda. (RTC) Rua Linda Abud Siufi 55 Cep: 05371-130 BR-Butantã, São Paulo, SP	Phone: +55 1137314515 Fax: +55 1137314516 E-mail: oliveira@rtc.net.br Internet: www.rtc.net.br
Czech Republic / Slovakia	BMC-TECH Hviezdoslavova 627 00 Brno	Phone: +420 545226047 Fax: +420 545226048 E-mail: info@bmc-tech.cz Internet: www.bmc-tech.cz
Chile	Ducasse Comercial Ltda. Av. Lib. Bernardo O'Higgins 1460, piso 8 Santiago	Phone: +56223557000 E-mail: contacto@ducasse.cl Internet: www.ducasse.cl
China	LingSheng Mech & Elec Science Technology Co., Ltd. Room 302, 22 building, Xinzhuan Rd. No.518 201612 Songjiang district, Shanghai	Phone: +86 2159761948 Fax: +86 2159769852 E-mail: sh@lsptc.com Internet: www.lsptc.com
	LSPTC GmbH (Vertretung in Deutschland) Kruppstraße 112 60388 Frankfurt am Main Deutschland	Phone: +49 6942690546 Fax: +49 6942690548 E-mail: info@lsptc.de Internet: www.lsptc.de
Denmark	Jens S. Transmissioner A/S Hørskættten 7 2630 Taastrup	Phone: +45 70138333 Fax: +45 43731911 E-mail: info@jens-s.dk Internet: www.jens-s.dk
Egypt	Islamco Imp. & Exp. 36 Ahmed Fakhry St. Nasr City, Cairo	Phone: +20 223547130 Fax: +20 223546669 E-mail: islamcoeg2002@yahoo.com Internet: www.islamcoimport.com
Estonia	AS Moduator Vohmanomme küla Lustivere tee 12 48028 Poltsamaa vald	Phone: +372 5034731 E-mail: kontakt@moduator.ee Internet: www.moduator.ee
Finland	SKS Mekaniikka Oy PL 122 01721 Vantaa	Phone: +358 2076461 Fax: +358 207646824 E-mail: mekaniikka@sk.fi Internet: www.sk.fi
France	Prud'homme Transmissions 25, Chemin d'Aubervilliers 93203 Saint-Denis Cedex	Phone: +33 148114600 Fax: +33 148344949 E-mail: info@prudhomme-trans.com Internet: www.prudhomme-trans.com
Greece	G. Anastasopoulos & Co. L.P. 60 Doridos Str. 122 42 Egaleo-Athens	Phone: +30 2105754215 Fax: +30 2105762587 E-mail: info@anastasopoulos.gr Internet: www.anastasopoulos.gr
Great Britain	Transmission Developments Co (G.B.) Ltd. Dawkins Road, Hamworthy, Poole Dorset BH15 4HF	Phone: +44 1202675555 Fax: +44 1202677466 E-mail: sales@transdev.co.uk Internet: www.transdev.co.uk



Guatemala, Honduras, El Salvador, Nicaragua	Productos y Servicios Técnicos, S.A. (Prosertec) Calzada Aguilar Batres 30-19 Zona 12 Guatemala 01012	Phone: +502 22130707 Fax: +502 24770849 E-mail: info@prosertec.com.gt Internet: www.prosertec.com.gt
Indonesia	Pt. Yogya Presisi Tehnikatama Industri Dhuri, Tirtomartani, Kalasan, Sleman Jl. Cangkringan 55571 Yogyakarta	Phone: +62 274498282 Fax: +62 274498474 E-mail: marketing@yogyapresisi.com Internet: www.yogyapresisi.com
Iceland	Idnver ehf. Tunguháls 10 110 Reykjavik	Phone: +354 5172220 E-mail: idnver@idnver.is Internet: www.idnver.is
Italy	Kuhn W. S.r.l. Via E.Mattei 84/13 40138 Bologna (BO)	Phone: +39 51531584 Fax: +39 51531611 E-mail: info@kuhnw.it Internet: www.kuhnw.it
	Bianchi Industrial s.p.a. Via Gianfranco Zuretti, 100 20125 Milano (MI)	Phone: +39 267861 E-mail: info@bianchi-industrial.it Internet: www.bianchi-industrial.it
Latvia	Pro Mehanika Ltd. Kurzemes prospects 164A Kurzemes rajons, Riga, LV-1029	Phone: +371 67808038 E-mail: birojs@promehanika.lv Internet: www.promehanika.lv
Lithuania	UAB „Dagmita“ Raudondvario pl. 162a 47174 Kaunas	Phone: +370 837363487 Fax: +370 837362260 E-mail: dagmita@dagmita.lt Internet: www.dagmita.lt
Montenegro / Macedonia	BELL d.o.o. Ptujaska Cesta 13 2204 Miklavž na Dravskem polju Slovenia	Phone: +386 26296920 Fax: +386 26292120 E-mail: info@bell.si Internet: www.bell.si
Netherlands	K & W Transmissies B.V. Poseisdonweg 31 8239 DK Lelystad	Phone: +31 320247370 Fax: +31 320246594 E-mail: info@kwtransmissies.nl Internet: www.kwtransmissies.nl
Norway	Jens S. Transmisjoner AS P.O. box 9, Manglerud 0612 Oslo	Phone: +47 23060400 Fax: +47 23060401 E-mail: post@jens-s.no Internet: www.jens-s.no
Peru	Ducasse Comercial del Peru Av. República de Panama 6426 Miraflores, Lima 18	Phone: +51 6118080 E-mail: master@ducasse.com.pe Internet: www.ducasse.com.pe
Poland	REALL Agencja Zaopatrzenia Technicznego ul. Wojciechowska 7 L 20-704 Lublin	Phone: +48 815361300 Fax: +48 814415181 E-mail: info@reall.pl Internet: www.reall.pl
Portugal	DUNBELT - Rolamentos e Transmissões Av. Casal da Serra nº 23 - r/c Dto 2625-085 Póvoa de Santa Iria	Phone: +351 219739030 Fax: +351 219731559 E-mail: compras@dunbelt.pt Internet: www.dunbelt.com
Serbia / Slovenia	BELL d.o.o. Ptujaska Cesta 13 2204 Miklavž na Dravskem polju Slovenia	Phone: +386 26296920 Fax: +386 26292120 E-mail: info@bell.si Internet: www.bell.si



Spain	Comercio Industria y Distribución, S.L Casas de Miravete, 24-B 4º2 28031 Madrid	Phone: +34 915072838 Fax: +34 915072773 E-mail: cid@cid.es Internet: www.cid.es
Sweden	Ingenjörfirman Kedjeteknik AB Baragatan 2 21228 Malmö	Phone: +46 40181000 Fax: +46 40932332 E-mail: info@kedjeteknik.se Internet: www.kedjeteknik.se
	Jens S. Transmissioner AB Koppargatan 9 60119 Norrköping	Phone: +46 11198000 Fax: +46 11198054 E-mail: info@jens-s.se Internet: www.jens-s.se
Switzerland	C. Plüss & Co. AG Oberdorfstr. 64 8600 Dübendorf	Phone: +41 448248800 Fax: +41 448248818 E-mail: service@pluss.com Internet: www.pluss.com
Turkey	Tampar Makina ve Ekipmanlari, Dis Tic. Ltd. Sti. Mimar Sinan Mah., Üsküdar cad., YEPDA Ticaret Merkezi E caddesi, No.70-71 34779 Atasehir-Istanbul	Phone: +90 2122520596 WhatsApp: +90 533 7380658 E-mail: tampar@tamagro.com Internet: www.tampar.com

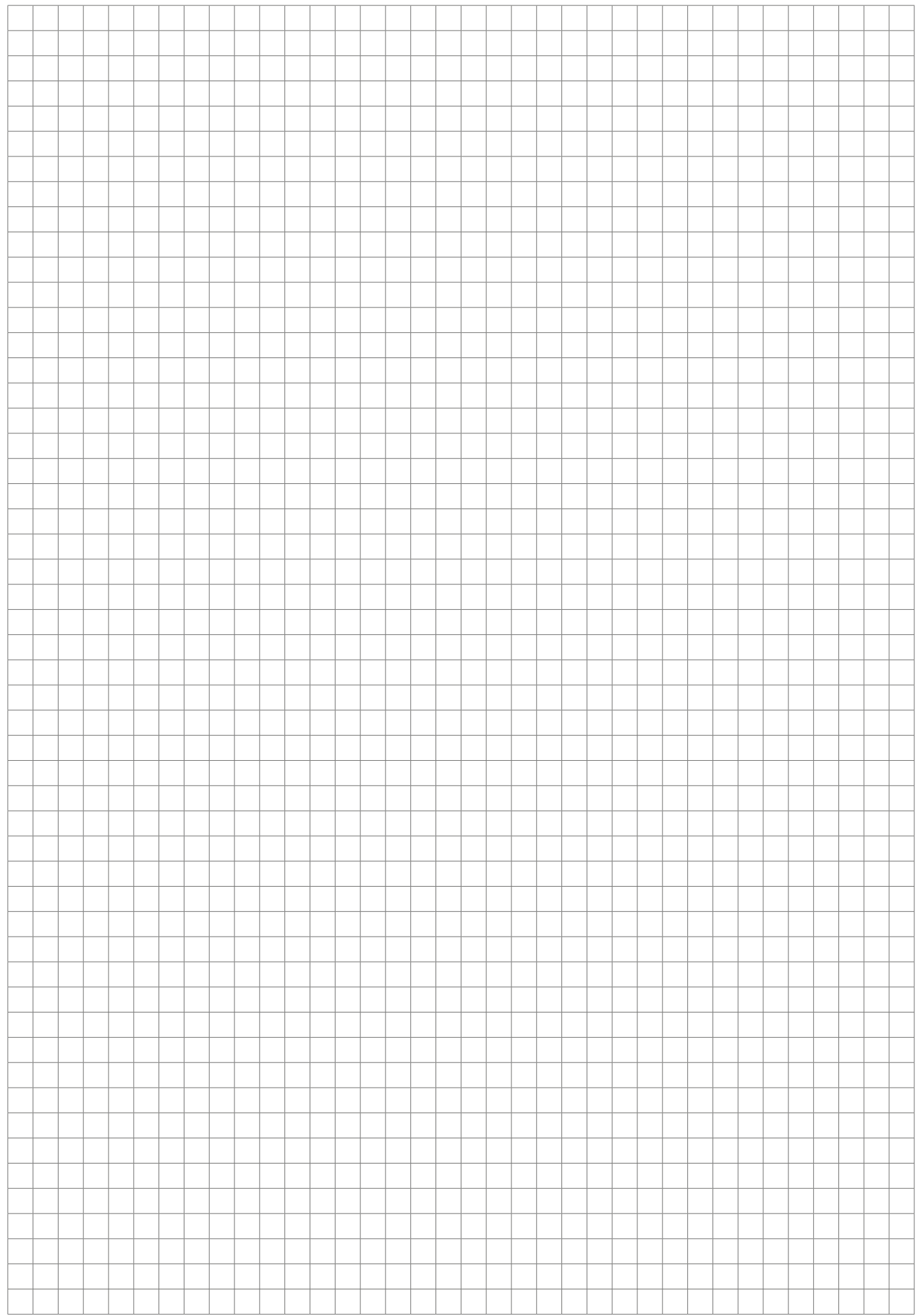

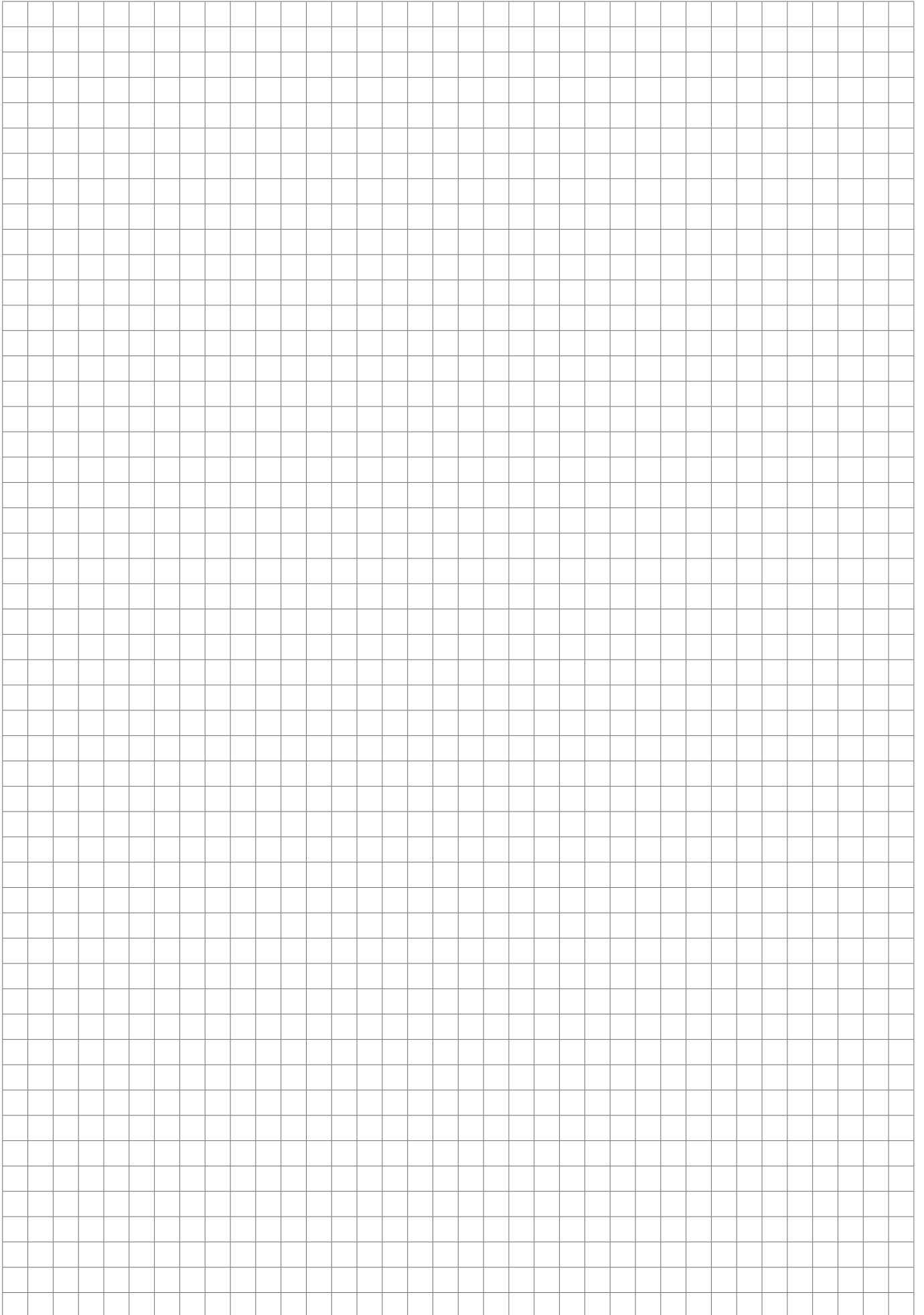

WIPPERMANN JR. GMBH
Delsterner Straße 133
58091 Hagen

Postfach 4020
58040 Hagen

Germany

Phone +49 23317820
Fax +49 2331782356

E-mail info@wippermann.com
Internet www.wippermann.com